

A-A (10:1)

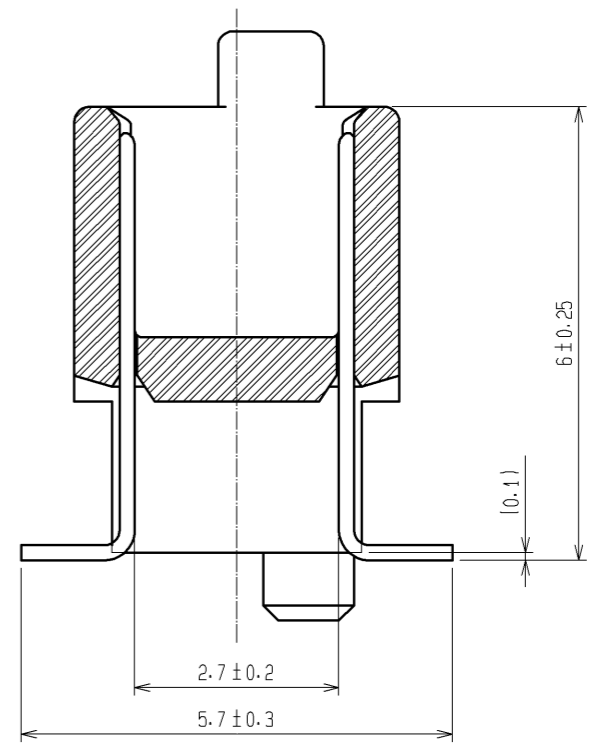

RECOMMENDED LAND PATTERN DIMENSIONS
(MOUNT SIDE)

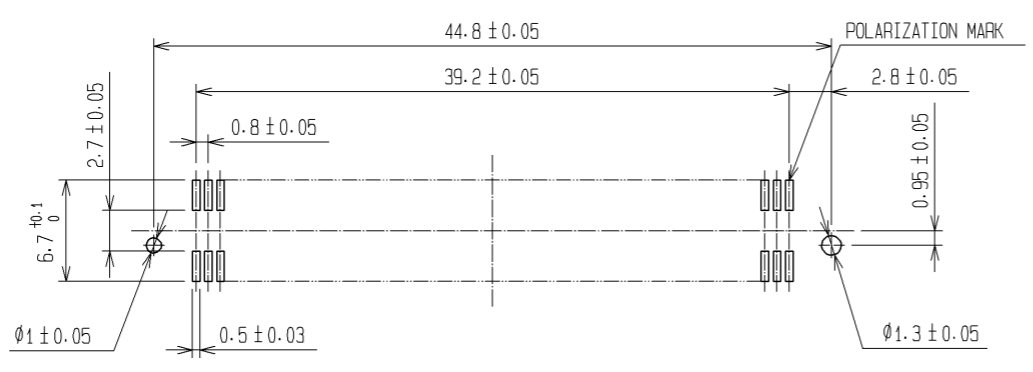

- NOTE
- 1 HRS MARK SHALL BE OPTIONAL.
 - 2 LEAD CO-PLANARITY SHALL BE 0.1mm MAX.
 - 3 TUBE PACKAGING SHALL BE APPLIED FOR THIS PRODUCT. SEE NEXT PAGE FOR DETAILS.
 - 4 THIS PRODUCT HAS TAPE FOR VACUUM PICKUP. SEE NEXT PAGE FOR DETAIL OF STICKING POSITION, ETC.
 - 5 FOR MODIFICATION, ETC. PREVENTIVE HOLE FOR SINK MARK MAY BE ADDED ACCORDING TO CIRCUMSTANCES.
 - 6 THE DIMENSIONS IN PARENTHESES ARE FOR REFERENCE.

1	PPS	LIGHT BROWN (UL94V-0)	2	PHOSPHOR BRONZE	CONTACT AREA : GOLD 0.1μm min. LEAD AREA : TIN-PLATING 1μm min. UNDER PLATING : NICKEL 1μm min.		
NO.	MATERIAL	FINISH . REMARKS	NO.	MATERIAL	FINISH . REMARKS		
UNITS mm		SCALE 2 : 1	COUNT △	DESCRIPTION OF REVISIONS	DESIGNED	CHECKED	DATE
HRS HIROSE ELECTRIC CO., LTD.		APPROVED : HS. OKAWA	07.06.06	DRAWING NO.	EDC3-084976-21		
		CHECED : HS. OZAWA	07.06.06	PART NO.	FX6-100P-0.8SV2(91)		
		DESIGNED : KT. DOI	07.06.06	CODE NO.	CL576-0048-7-91		
		DRAWN : TS. MIYAKI	07.06.01		△ 1/2		

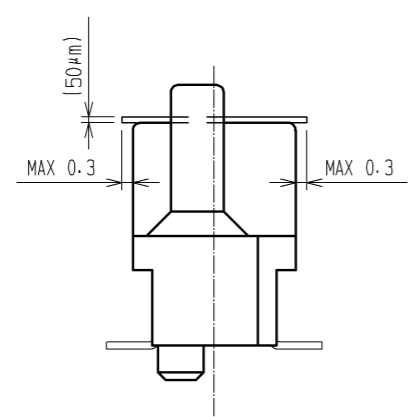
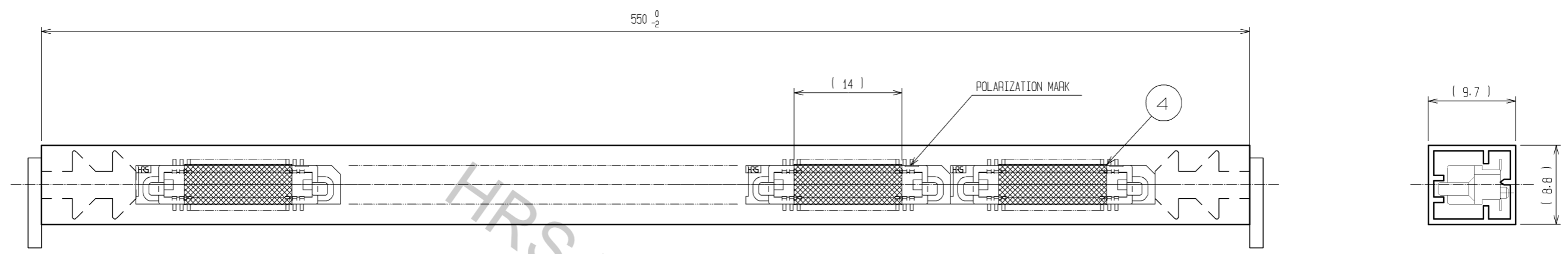

- NOTE 1 THE DIMENSIONS IN PARENTHESES ARE FOR REFERENCE.
 2 ONE TUBE CONSISTS OF 11 PIECES.
 3 REMOVE THE VACUUM PICK-UP TAPE AFTER MOUNTING THE CONNECTOR.

2	PVC	(STOPPER)	4	POLYIMIDE	(TAPE FOR VACUUM PICK-UP)			
1	PVC	(TUBE)	3		(CONNECTOR)			
NO.	MATERIAL	FINISH . REMARKS	NO.	MATERIAL	FINISH . REMARKS			
UNITS mm		SCALE FREE		COUNT	DESCRIPTION OF REVISIONS	DESIGNED	CHECKED	DATE
HRS HIROSE ELECTRIC CO., LTD.		APPROVED : HS. OKAWA	07.06.06	DRAWING NO. EDC3-084976-21				
		CHECED : HS. OZAWA	07.06.06	PART NO. FX6-100P-0.8SV2(91)				
		DESIGNED : KT. DOI	07.06.06	CODE NO. CL576-0048-7-91				
		DRAWN : TS. MIYAKI	07.06.01					