

THIS DRAWING IS UNPUBLISHED. RELEASED FOR PUBLICATION 20  
 © COPYRIGHT 20 BY - ALL RIGHTS RESERVED.

LOC	DIST	REVISIONS			
P	LTR	DESCRIPTION	DATE	DWN	APVD
FX	00	A	INITIAL RELEASE	17DEC2012	DD MB

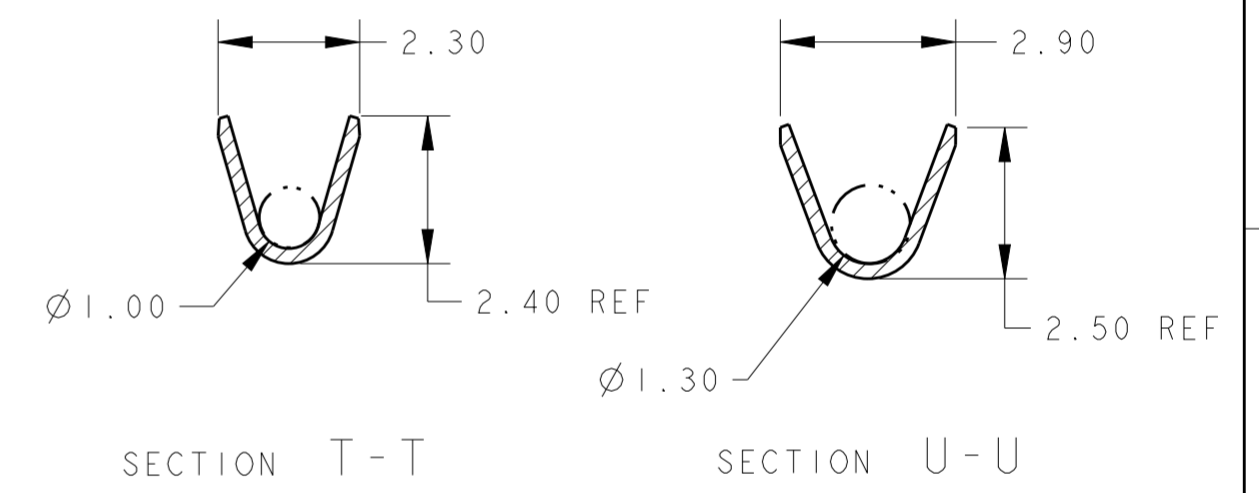

- 1 MATERIAL: 0.25 THK BRASS
- 2 FINISH: 0.0025 MIN THK TIN IN LOCALIZED TIN PLATE AREA AND 0.00076 MIN THK GOLD IN GOLD PLATE AREA, ALL OVER 0.002 MIN THK NICKEL.
- 3 FEATURE ON CARRIER STRIP IS RAISED TO INDICATE GOLD PLATED PRODUCT FEATURE APPEARS ADJACENT TO EVERY OTHER CONTACT MIN.
- 4 SEE FIGURE 1 FOR REELING DIRECTION.
- 5. TERMINAL LUBRICATED WITH CHEMLUB 1102.
- 6 AMP TRADEMARK STAMPED IN THIS APPROXIMATE LOCATION. OPPOSITE SIDE.
- 7 WEEK CODE (YWW) STAMPED IN THIS APPROXIMATE LOCATION. OPPOSITE SIDE.

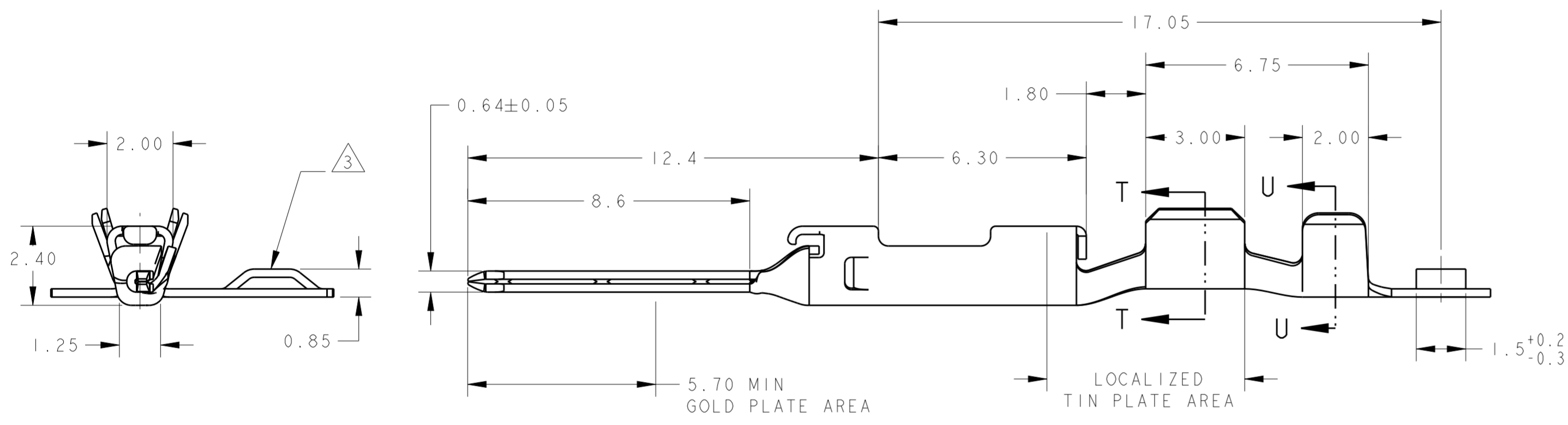
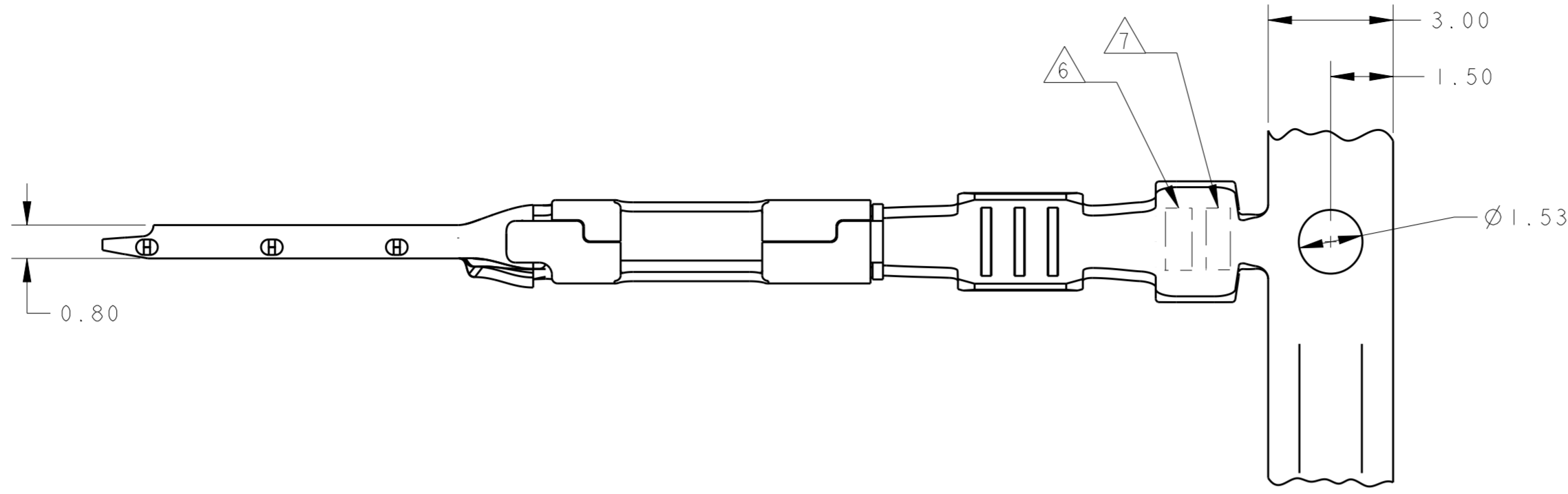
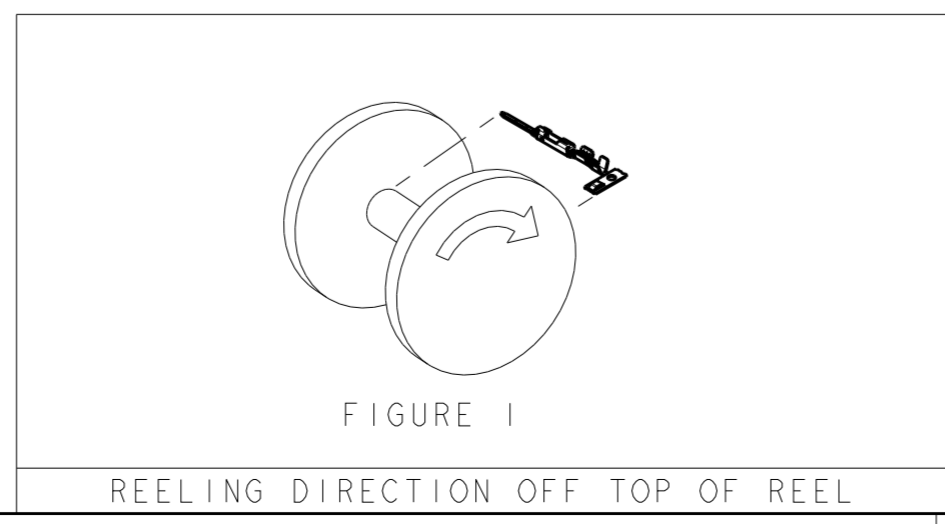

4	18-20	2203521-1
REELING	WIRE SIZE	PART NUMBER

THIS DRAWING IS A CONTROLLED DOCUMENT.		DWN D. DRUMMOND 17DEC2012	TE Connectivity	
DIMENSIONS: mm		CHK M. BANAS 17DEC2012		
TOLERANCES UNLESS OTHERWISE SPECIFIED:		APVD M. BANAS 17DEC2012	NAME CONTACT, MALE, 0.64MM, GOLD PLATED	
0 PLC ±	±0.3	PRODUCT SPEC	SIZE CAGE CODE DRAWING NO	
1 PLC ±	±0.2	APPLICATION SPEC	RESTRICTED TO	
2 PLC ±	±	114-13006	A20779C-2203521	
3 PLC ±	±	WEIGHT	SCALE 8:1 SHEET 1 OF 1 REV A	
4 PLC ±	±2°	CUSTOMER DRAWING		
ANGLES ±	±2°			
FINISH				