

7Z020727

(ON 0NIMARD) 台器理図

版数 REV.	年月日 DATE	DCN NO.	変更内容 DESCRIPTION	製図 DR.	担当 CHK.	査閲 APPD.	承認 APPD.
2	8.Sep.1989	25662	REVISED MAGAZINE FORM, REDRAWN				
3	31.Jul.1991	29097	DELETE NOTE 5	J.ICHIMYAMA (KITADA)	K.IBARAKI	T.KOSUGE	H.FUJINO
4	18.Mar.2010	069662	REVISED NOTE 4 AND JAPANESE-BILINGUAL	M.SAITOU	N.UCHIYAMA		Y.MIZUSAWA
5	15.Jul.2010	070319	REVISED APPLICABLE WIRE DIAMETER	M.SAITOU	N.UCHIYAMA		y. MIZUSAWA

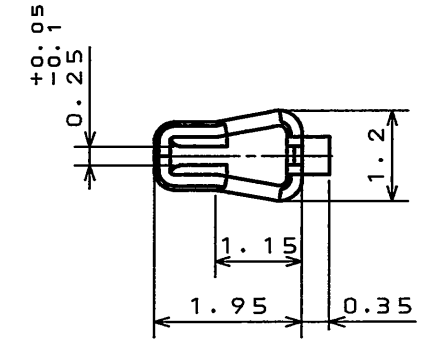
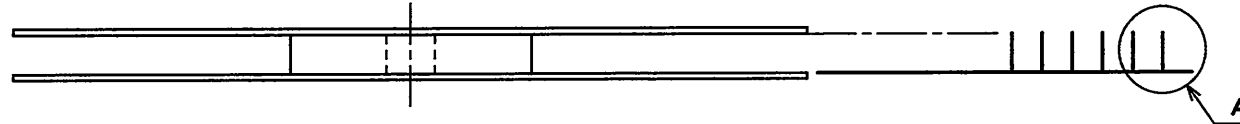

EXCLUDING CRIMP POT  
クリンプポット部を除く

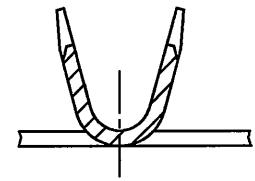
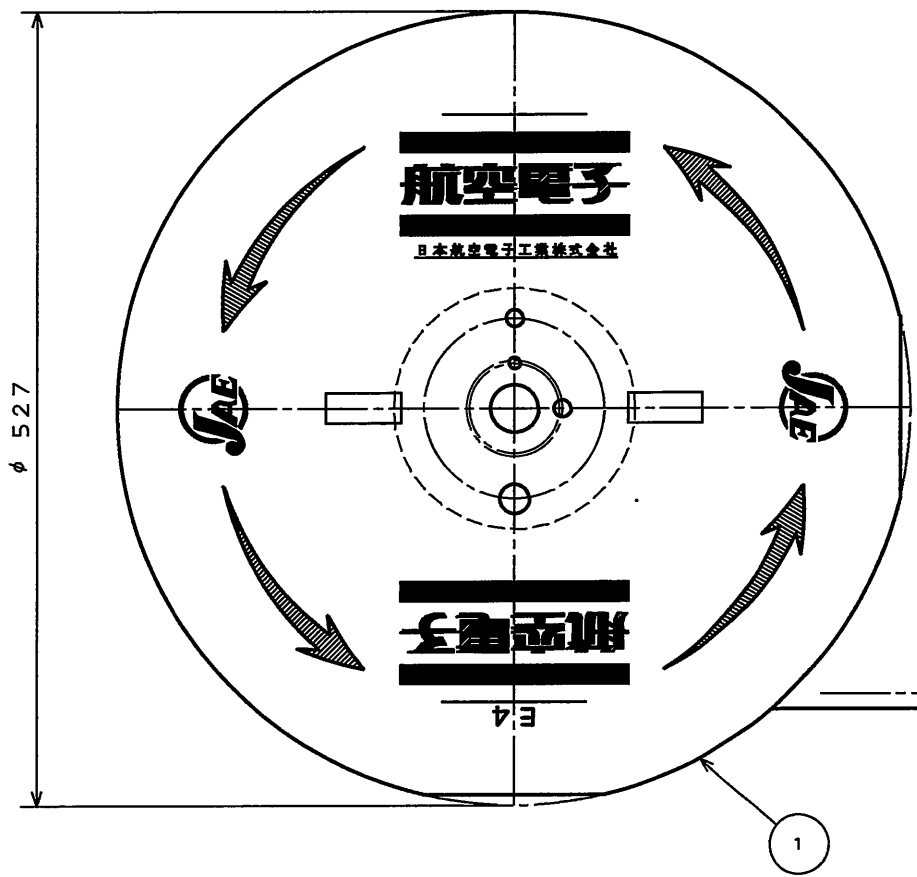

DETAIL B (SCALE 10:1)  
(EXCLUDING MATED PORTION)  
(嵌合部を除く)

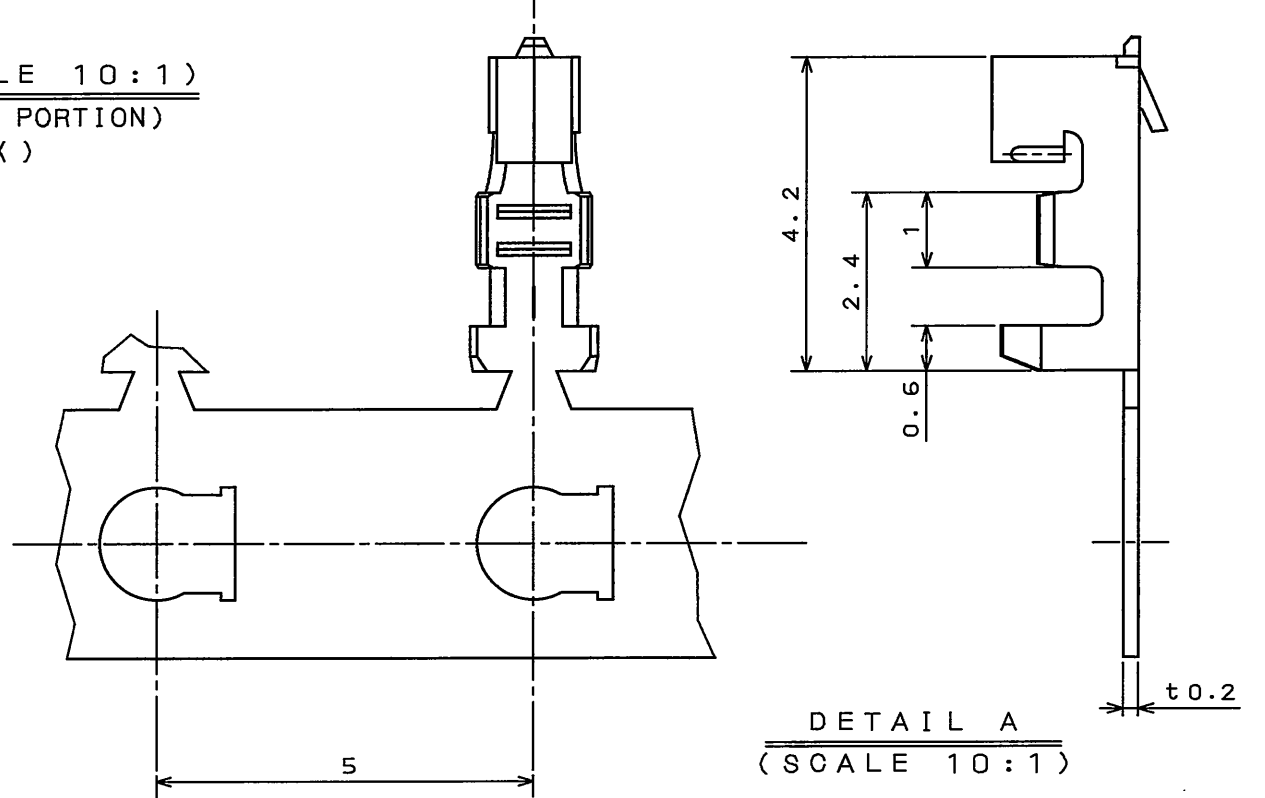

DETAIL A  
(SCALE 10:1)

NOTE 1. INSERT PIN: □0.4 ±0.05

- △ 2. APPLICABLE WIRE : #26~#30AWG, STRANDED.  
APPLICABLE WIRE INSULATION OUTER φ0.7 to φ1.0.
  - 3. NO PLATING ON THE SHEARED AREA OF CONTACT.
  - △ 4. APPLICABLE CRIMPING MACHINE FOR  
IL-Y-C3-A-10000(MAGAZINE ASS'Y) IS 350-ILY-2B
- 注 1. 挿入ピンは□0.4 ±0.05とする。
- △ 2. 使用電線はAWG #26~#30の撚線とし、被覆外径はφ0.7~φ1.0
  - 3. 剪断面に、メッキは付かない。
  - △ 4. IL-Y-C3-A-10000(マガジンアッセンブリ)は、次の半自動圧着機に装着する。350-ILY-2B

3	SOCKET CONTACT	10000	PHOSPHOR BRONZE	TIN PLATING	
2	TAPE	1	PAPER		
1	MAGAZINE	1	PAPER		
符号 NO.	名称 DESCRIPTION	個数 QTY.	材料 MATERIAL	仕上 FINISH	備考 REMARKS
仕様書 (SPECIFICATION)		第1版 (ORIGINAL DATE) 27.Feb.1986		尺度 (SCALE)	シリーズ (SERIES) IL-Y
公差 (GENERAL TOLERANCE)		製図 DR. J.HAYAKAWA		名称 (TITLE) IL-Y-C3-A-10000 (MAGAZINE ASSEMBLY)	
寸法 (DIMENSION)		担当 CHK. K.IBARAKI		日本航空電子工業株式会社 JAPAN AVIATION ELECTRONICS INDUSTRY, LTD.	
角度 (ANGLES)		査閲 APPD. T.MIYASHITA			
. ±0.8 X° ± .X ±0.5 X°X' ± .XX ±0.2 .XXX ±		承認 APPD. H.FUJINO			
		質量 (MASS)		図面番号 (DRAWING NO.) SJ020727	

DOF-0-212F(05.08)



SIZE A3  
版数 (REV.)  
5