

PART NUMBER	REV	FIRST USED
680334-1	C	122500-1
680334-2	C	565435-5

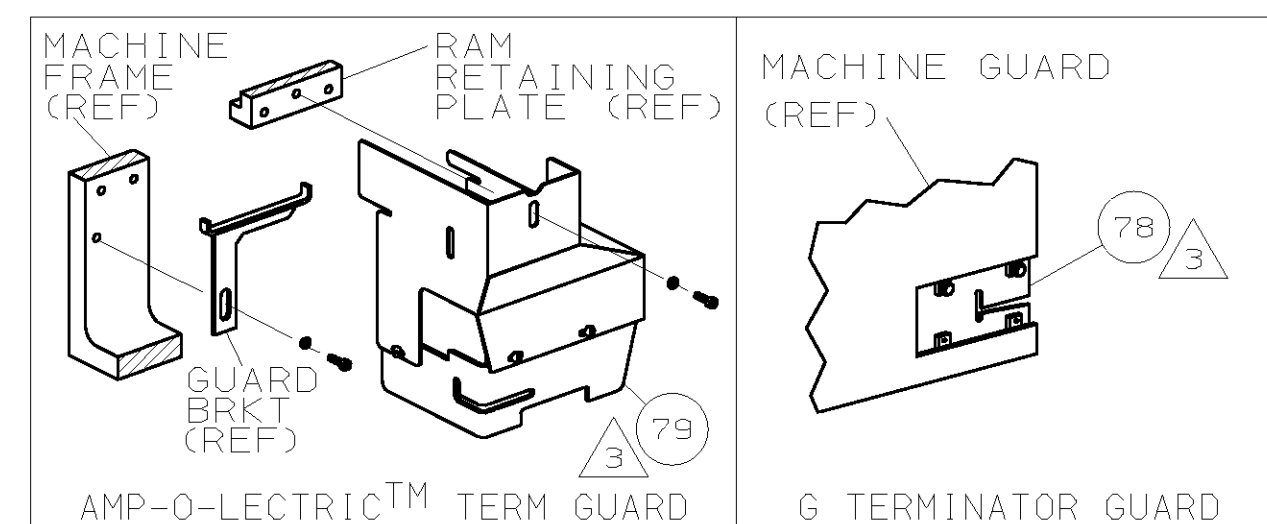

TERMINAL NAME:	SPECIAL	TERMINAL	CRIMPING DATA			
	63671 61462		PAD LTR	CRIMP HEIGHT	WIRE SIZE	
			A	.071 ±.002 [1.80 ±0.05mm]	18	
			B	.066 ±.002 [1.68 ±0.05mm]	22	
			C	NOT	USED	
			D	NOT	USED	
			CRIMP	SIZE	TYPE	RANGE
			WIRE			
			INSUL	.120 [3.05mm]	BLUNT F	.085
WIRE STRIP LENGTH	TERM APPL SPEC	FEED	APPL INSTRUCTION	SET UP GAGE	LAYOUT	
-	NONE	.717	408-8039	458638-1	L1792	

-1	LEADMAKER & BENCH MODEL G	MECH POST FEED	
-2	BENCH MODEL K	MECH POST FEED	

REF	REF	-	A	22594-8	NUT, HEX	70
REF	REF	-	B	240628-1	PLATE, ADJ	69
REF	REF	-	B	240626-1	SHAFT, PIVOT	68
REF	REF	-	B	240633-1	BUSHING	67
REF	REF	-	A	455680-1	LEVER, INTERMEDIATE	66
REF	REF	-	B	240629-1	BLOCK, PIVOT	65
REF	REF	-	A	240632-2	SCR, ADJ	64
REF	REF	-	B	240659-3	PIN, CAM ROLLER	63
REF	REF	-	B	240658-1	CAM, ROLLER	62
REF	REF	-	B	454398-1	ROD, FEED	61
REF	REF	-	C	454220-1	CAP, RAM	59
REF	REF	-	D	453736-1	HOUSING	58
REF	REF	-	B	240624-1	PIN, FEED FINGER	55
REF	REF	-	B	691499-1	SPRING, FEED FINGER	54
REF	REF	-	B	240635-1	FINGER, FEED	53
REF	REF	-	B	240634-1	LEVER, TERMINAL	52
REF	REF	-	B	690501-3	CAM, POST FEED 1 1/8 ST	48
REF	REF	-	B	690501-4	CAM, POST-FEED 1 5/8 ST	47
REF	REF	-	A	690191-1	PLUG, NYLON	45
REF	REF	-	C	455674-1	RAM	44
REF	REF	-	A	690125-1	WASHER, LAMINATED	43
REF	REF	-	A	690124-1	WASHER, RAM	42
REF	REF	-	A	7-21002-9	BOLT, CRIMPER (5/16-24x1.00)	41
REF	REF	-	A	690223-2	SPACER, INSULATION DISC	38
REF	REF	-	D	354777-1	WIRE DISC, PLASTIC	37
REF	REF	-	A	22480-5	WASHER, SPRING	36
REF	REF	-	B	690212-1	POST, RAM	35
REF	REF	-	D	458980-1	APPLICATOR, BASIC (SUB ASSY)	32
REF	REF	-	B	4-690451-7	SPACER, STRIPPER	28
REF	REF	-	A	240639-2	STRIPPER	27
REF	REF	-	C	455676-1	PLATE, BASE	26
REF	REF	-	A	22354-8	DRAG, STUD	25
REF	REF	-	B	455678-1	PLATE, STRIP GUIDE	24
REF	REF	-	C	240825-1	PLATE, STRIP HOLD DOWN	23
REF	REF	-	A	4-22281-1	SPRING, DRAG	22
REF	REF	-	A	454177-1	DRAG, STOCK	20
REF	REF	-	C	454204-3	GUIDE, STRIP (FRONT)	18
REF	REF	-	A	454178-1	GUIDE, FEED ROD	17
REF	REF	-	A	4-22284-9	SPRING, FEED RETURN	16
REF	REF	-	A	23846-1	SPRING, HOLD DOWN	12
REF	REF	-	B	240644-1	PLATE, REAR SHEAR	11
REF	REF	-	B	690482-6	PLATE, FRONT SHEAR	9
REF	REF	-	D	454435-6	ANVIL	8
REF	REF	-	B	690474-6	BLADE, SLUG	7
REF	REF	-	D	1-455892-5	HOLD DOWN, TERMINAL	6
REF	REF	-	C	7-240641-1	SPACER, SLUG BLADE	5
REF	REF	-	C	1-459585-6	CRIMPER, INSULATION	3

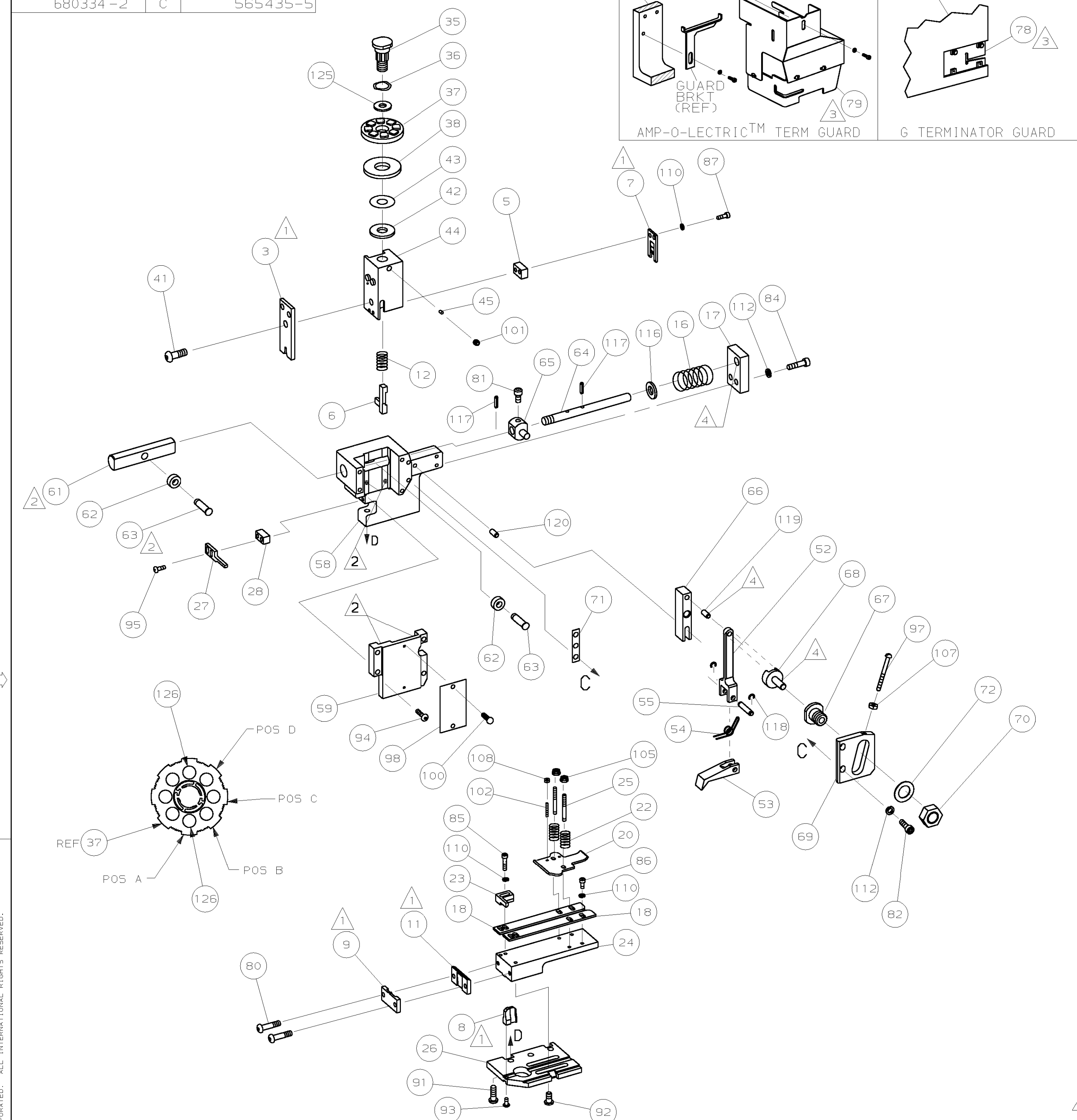

REF	REF	-	A	1-21030-7	PIN, DOWEL (Ø.187x1.50) H56	120
REF	REF	-	A	1-21030-1	PIN, DOWEL (Ø.187x.50) LEVER	119
REF	REF	-	A	21045-3	RING, RET "C" (Ø.187) FD PIN	118
REF	REF	-	A	5-21028-1	PIN, STD SPRING (Ø.12) FD ADJ ROD	117
REF	REF	-	A	21899-4	WASHER, FLAT (Ø5/16) SCR ADJ	116
REF	REF	-	A	21024-5	WASHER, LOCK (NO.10) FD ROD GDE	112
REF	REF	-	A	21024-4	WASHER, LOCK (NO.8) SHEAR BL	110
REF	REF	-	A	21018-4	NUT, HEX (4-40) DRAG	108
REF	REF	-	A	21018-5	NUT, HEX (6-32) FD ADJ PL	107
REF	REF	-	A	21022-2	NUT, HEX SL (8-32) DRAG STUD	105
REF	REF	-	A	2-21006-6	SCR, SKT SET (4-40x.62) DRAG	102
REF	REF	-	A	21009-2	SCR, SKT SET (1/4-20x.25) RAM	101
REF	REF	-	A	21017-2	SCR, DRIVE (#2x.19) ID PLATE	100
REF	REF	-	A	1-21002-7	SCR, BHC (6-32x.38) CAM	99
REF	REF	-	B	461264-1	PLATE, IDENTIFICATION	98
REF	REF	-	A	6-23715-5	SCR, PAN HD (6-32x1.50) FEED ADJ	97
REF	REF	-	A	2-21002-2	SCR, BHC (8-32x.50) STRIPPER	95
REF	REF	-	A	2-21002-9	SCR, BHC (10-32x.75) H56 CAP	94
REF	REF	-	A	22733-8	SCR, BHC (8-32x.38 LW) ANVIL	93
REF	REF	-	A	3-21002-3	SCR, BHC (1/4-20x.50) ST 6D PL	92
REF	REF	-	A	2-22733-8	SCR, BHC (1/4-20x.62) BASE PL	91
REF	REF	-	A	3-21000-6	SCR, 5HC (10-32x.62) FEED ADJ PL	82
REF	REF	-	A	3-21000-4	SCR, 5HC (10-32x.38) PIVOT BLOCK	81
REF	REF	-	A	3-21002-0	SCR, BHC (10-32x.88) SHEAR PL	80
REF	REF	-	A	455745-1	GUARD, WINDOW	79
REF	REF	-	A	679532-1	INSERT, GUARD	78
REF	REF	-	A	458109-1	WASHER, FLAT (SPECIAL)	72
REF	REF	-	A	690517-1	SPACER	71
REF	REF	-	A	458109-1	WASHER, FLAT (SPECIAL)	72
REF	REF	-	A	690517-1	SPACER	71

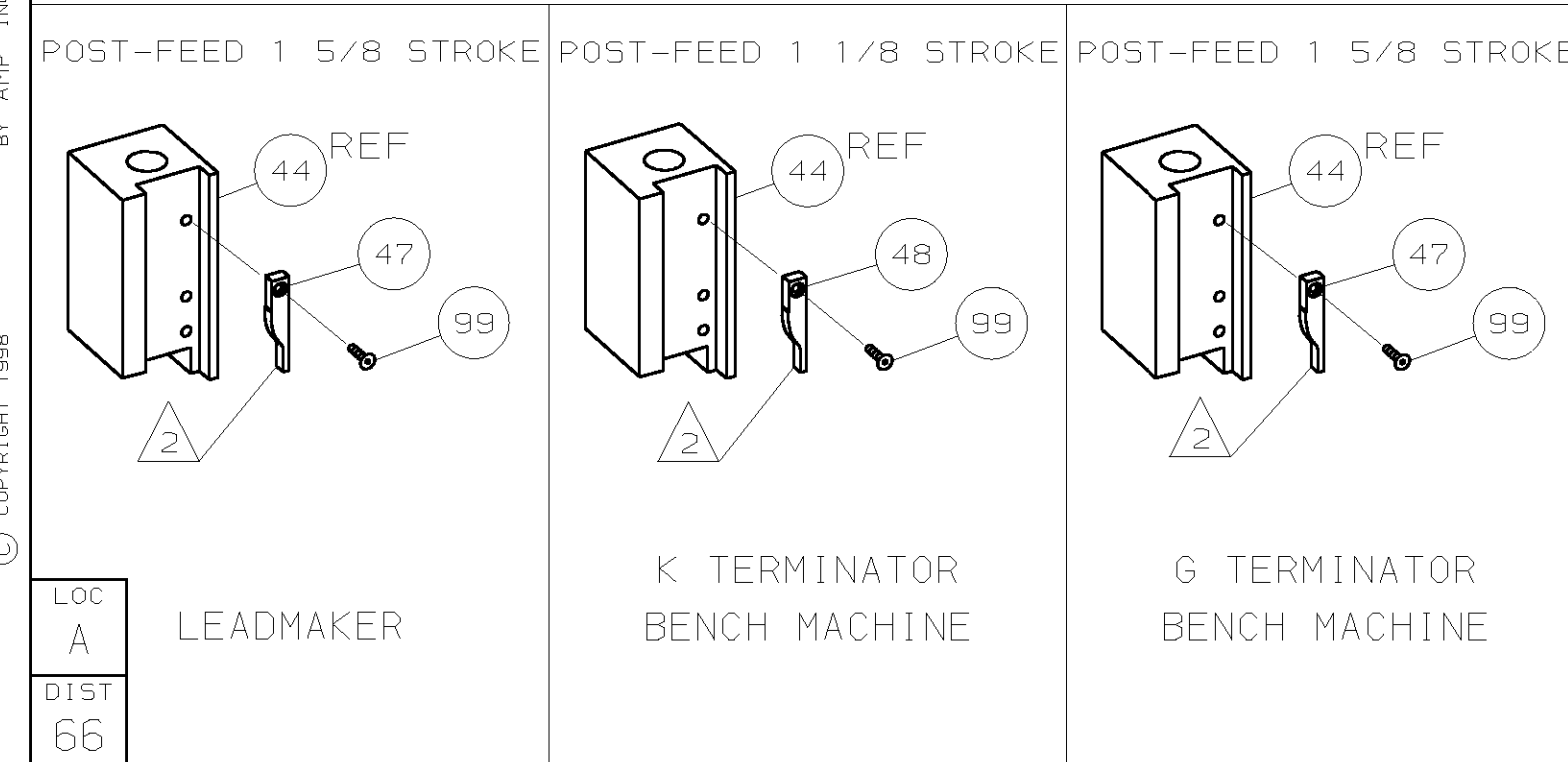

- 1 RECOMMENDED SPARE PARTS.
- 2 GREASE LIGHTLY.
- 3 GUARD MUST BE IN PLACE WHEN OPERATING APPLICATOR IN A BENCH MACHINE.
- 4 LUBRICATE DAILY USING NO. 20 MACHINE OIL.
- 5. ITEMS WITH QTY OF REF SPECIFIED (EXCEPT ITEMS 78 AND 79) ARE USED ON ITEM 32.
- 6 ITEM 78 USED WITH 6 TERMINATOR ONLY.
- 7 USE CUSTOMER WIRE FOR SET-UP.

QTY	RECD PER ASSY	U/M	DWG SIZE	PART NO	DESCRIPTION	ITEM NO
-2	-1	U/M	DWG SIZE	PART NO	DESCRIPTION	ITEM NO

QTY	RECD PER ASSY	U/M	DWG SIZE	PART NO	DESCRIPTION	ITEM NO
-2	-1	U/M	DWG SIZE	PART NO	DESCRIPTION	ITEM NO