

Development Board EPC9017

Quick Start Guide

100 V Half-Bridge with Gate Drive, Using EPC2001



DESCRIPTION

www.epc-co.com

The EPC9017 development board features the 100 V EPC2001 enhancement mode (*eGaN*[®]) field effect transistor (FET) operating up to a 20 A maximum output current in a half bridge configuration with onboard gate drives. The purpose of this development board is to simplify the evaluation process of the EPC2001 *eGaN FET* by including all the critical components on a single board that can be easily connected into any existing converter.

The EPC9017 development board is 2" x 1.5" and features three EPC2001 *eGaN FETs* in a half bridge configuration using the Texas Instruments LM5113 gate driver. The half bridge configuration

contains a single top side device and two parallel bottom devices and is recommended for high current, **lower duty cycle** applications. The board contains all critical components and the printed circuit board (PCB) layout is designed for optimal switching performance. There are also various probe points to facilitate simple waveform measurement and evaluate *eGaN FET* efficiency. A complete block diagram of the circuit is given in Figure 1.

For more information on the EPC2001s *eGaN FET* please refer to the datasheet available from EPC at www.epc-co.com. The datasheet should be read in conjunction with this quick start guide.

Table 1: Performance Summary (TA = 25°C)

SYMBOL	PARAMETER	CONDITIONS	MIN	MAX	UNITS
V _{DD}	Gate Drive Input Supply Range		7	12	V
V _{IN}	Bus Input Voltage Range			70*	V
V _{OUT}	Switch Node Output Voltage			100	V
I _{OUT}	Switch Node Output Current			20*	A
V _{PWM}	PWM Logic Input Voltage Threshold	Input 'High'	3.5	6	V
		Input 'Low'	0	1.5	V
	Minimum 'High' State Input Pulse Width	V _{PWM} rise and fall time < 10ns	60		ns
	Minimum 'Low' State Input Pulse Width	V _{PWM} rise and fall time < 10ns	200#		ns

* Assumes lower duty cycle inductive load, maximum current depends on die temperature – actual maximum current will be subject to switching frequency, bus voltage and thermals.

Limited by time needed to 'refresh' high side bootstrap supply voltage.

Quick Start Procedure

Development board EPC9017 is easy to set up to evaluate the performance of the EPC2001 *eGaN FET*. Refer to Figure 2 for proper connect and measurement setup and follow the procedure below:

1. With power off, connect the input power supply bus to $+V_{IN}$ (J5, J6) and ground / return to $-V_{IN}$ (J7, J8).
2. With power off, connect the switch node of the half bridge OUT (J3, J4) to your circuit as required.
3. With power off, connect the gate drive input to $+V_{DD}$ (J1, Pin-1) and ground return to $-V_{DD}$ (J1, Pin-2).
4. With power off, connect the input PWM control signal to PWM (J2, Pin-1) and ground return to any of the remaining J2 pins.
5. Turn on the gate drive supply – make sure the supply is between 7 V and 12 V range.
6. Turn on the bus voltage to the required value (do not exceed the absolute maximum voltage of 100 V on V_{OUT}).
7. Turn on the controller / PWM input source and probe switching node to see switching operation.
8. Once operational, adjust the bus voltage and load PWM control within the operating range and observe the output switching behavior, efficiency and other parameters.
9. For shutdown, please follow steps in reverse.

NOTE. When measuring the high frequency content switch node (OUT), care must be taken to avoid long ground leads. Measure the switch node (OUT) by placing the oscilloscope probe tip through the large via on the switch node (designed for this purpose) and grounding the probe directly across the GND terminals provided. See Figure 3 for proper scope probe technique.

THERMAL CONSIDERATIONS

The EPC9017 development board showcases the EPC2001 *eGaN FET*. Although the electrical performance surpasses that for traditional silicon devices, their relatively smaller size does magnify the thermal management requirements. The EPC9017 is intended for bench evaluation with low ambient temperature and convection cooling. The addition of heat-sinking and forced air cooling can significantly increase the current rating of these devices, but care must be taken to not exceed the absolute maximum die temperature of 125°C.

NOTE. The EPC9017 development board does not have any current or thermal protection on board.

Table 2 : Bill of Material

Item	Qty	Reference	Part Description	Manufacturer / Part #
1	3	C4, C10, C11,	Capacitor, 1uF, 10%, 25V, X5R	Murata, GRM188R61E105KA12D
2	2	C16, C17	Capacitor, 100pF, 5%, 50V, NP0	Kemet, C0402C101K5GACTU
3	2	C9, C19	Capacitor, 0.1uF, 10%, 25V, X5R	TDK, C1005X5R1E104K
4	3	C21, C22, C23	Capacitor, 1uF, 10%, 100V, X7R	TDK, CGA4J3X7S2A105K125AE
5	2	D1, D2	Schottky Diode, 30V	Diodes Inc., SDM03U40-7
6	3	J1, J2, J9	Connector	2pins of Tyco, 4-103185-0
7	1	J3, J4, J5, J6, J7, J8	Connector	FCI, 68602-224HLF
8	3	Q1, Q2, Q3	eGaN® FET	EPC, EPC2001
9	1	R1	Resistor, 10.0K, 5%, 1/8W	Stackpole, RMCF0603FT10K0
10	2	R2, R15	Resistor, 0 Ohm, 1/8W	Stackpole, RMCF0603ZT0R00
11	1	R4	Resistor, 22 Ohm, 1%, 1/8W	Stackpole, RMCF0603FT22R0
12	1	R5	Resistor, 47 Ohm, 1%, 1/8W	Stackpole, RMCF0603FT47R0
13	6	R19, R20, R21, R22, R23, R24	Resistor, 0 Ohm, 1/16W	Stackpole, RMCF0402ZT0R00
14	2	TP1, TP2	Test Point	Keystone Elect, 5015
15	1	TP3	Connector	1/40th of Tyco, 4-103185-0
16	1	U1	I.C., Logic	Fairchild, NC7SZ00L6X
17	1	U2	I.C., Gate driver	Texas Instruments, LM5113TME
18	1	U3	I.C., Regulator	Microchip, MCP1703T-5002E/MC
19	1	U4	I.C., Logic	Fairchild, NC7SZ08L6X
20	0	R14	Optional Resistor	
21	0	D3	Optional Diode	
22	0	P1, P2	Optional Potentiometer	

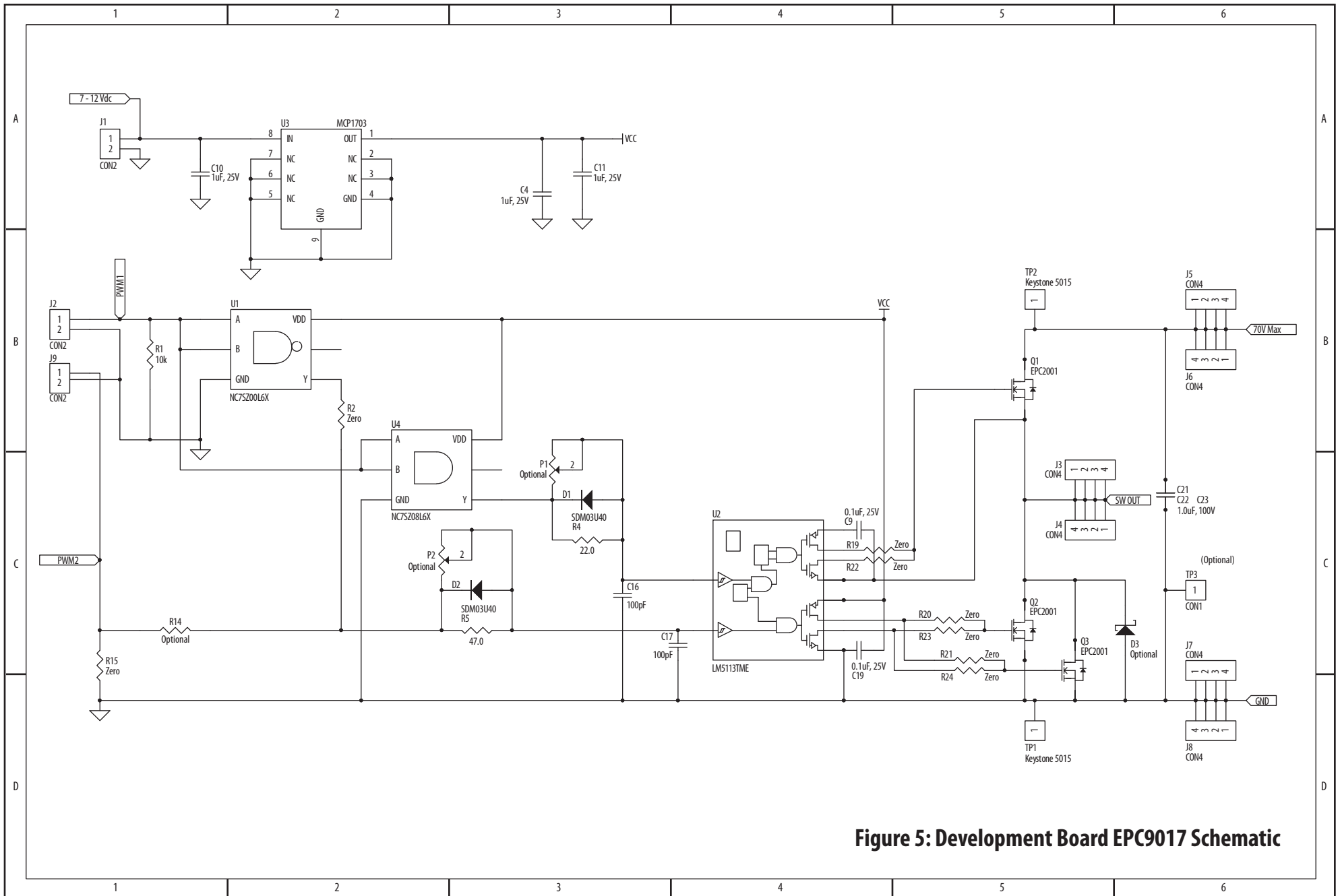

Figure 5: Development Board EPC9017 Schematic

Contact us:

www.epc-co.com

Renee Yawger

WW Marketing

Office: +1.908.475.5702

Mobile: +1.908.619.9678

renee.yawger@epc-co.com

Stephen Tsang

Sales, Asia

Mobile: +852.9408.8351

stephen.tsang@epc-co.com

Bhasy Nair

Global FAE Support

Office: +1.972.805.8585

Mobile: +1.469.879.2424

bhasy.nair@epc-co.com

Peter Cheng

FAE Support, Asia

Mobile: +886.938.009.706

peter.cheng@epc-co.com



EPC Products are distributed exclusively through Digi-Key.
www.digikey.com

Development Board / Demonstration Board Notification

The EPC9017 board is intended for product evaluation purposes only and is not intended for commercial use. As an evaluation tool, it is not designed for compliance with the European Union directive on electromagnetic compatibility or any other such directives or regulations.

As board builds are at times subject to product availability, it is possible that boards may contain components or assembly materials that are not RoHS compliant. Efficient Power Conversion Corporation (EPC) makes no guarantee that the purchased board is 100% RoHS compliant.

No Licenses are implied or granted under any patent right or other intellectual property whatsoever. EPC assumes no liability for applications assistance, customer product design, software performance, or infringement of patents or any other intellectual property rights of any kind.

EPC reserves the right at any time, without notice, to change said circuitry and specifications.