

## Low Voltage PLL Clock Driver

The MPC9350 is a 2.5 V and 3.3 V compatible, PLL-based clock generator targeted for high performance clock distribution systems. With output frequencies of up to 200 MHz and maximum output skews of 150 ps, the MPC9350 is ideal for the most demanding clock tree designs. The device offers 9 low skew clock outputs, with each one configurable to support the clocking needs of the various high-performance microprocessors, including the PowerQUICC II integrated communication microprocessor. The extended temperature range of the MPC9350 supports telecommunication and networking requirements. The device employs a fully differential PLL design to minimize cycle-to-cycle and long-term jitter.

### Features

- 9 output LVCMOS PLL clock generator
- 25 – 200 MHz output frequency range
- 2.5 V and 3.3 V compatible
- Compatible to various microprocessors such as PowerQuicc II
- Supports networking, telecommunications and computer applications
- Fully integrated PLL
- Configurable outputs: divide-by-2, 4 and 8 of VCO frequency
- Selectable output to input frequency ratio of 8:1, 4:1, 2:1 or 1:1
- Oscillator or crystal reference inputs
- Internal PLL feedback
- Output disable
- PLL enable/disable
- Low skew characteristics: maximum 150 ps output-to-output
- 32-lead LQFP package
- 32-lead Pb-free Package Available
- Temperature range  $-40^{\circ}\text{C}$  to  $+85^{\circ}\text{C}$

### Functional Description

The MPC9350 generates high frequency clock signals and provides nine exact frequency-multiplied copies of the reference clock signal. The internal PLL allows the MPC9350 to operate in frequency locked condition and to multiply the input reference clock. The reference clock frequency and the divider in the internal feedback path determine the VCO frequency. Two selectable PLL feedback frequency ratios are available on the MPC9350 to provide input frequency range flexibility. The FBSEL pin selects between divide-by-16 or divide-by-32 of the VCO frequency for PLL feedback. This feedback divider must be selected to match the VCO frequency range. With the available feedback output dividers, the internal VCO of the MPC9350 is running at either 16x or 32x of the reference clock frequency. The frequency of the QA, QB, QC and QD outputs is either one half, one fourth or one eighth of the selected VCO frequency and can be configured for each output bank using the FSELA, FSELB, FSELC and FSELD pins, respectively. The available output to input frequency ratios are 16:1, 8:1, 4:1 and 2:1. The REF\_SEL pin selects the crystal oscillator input or the LVCMOS compatible reference input (TCLK). TCLK also provides an external test clock in static test mode when the PLL enable pin (PLL\_EN) is pulled to logic low state. In test mode, the selected input reference clock is routed directly to the output dividers without using the PLL. The test mode is intended for system diagnostics, test and debug purposes. This test mode is fully static and the minimum clock frequency specification does not apply. The outputs can be disabled by deasserting the  $\overline{\text{OE}}$  pin (logic high state). In PLL mode, deasserting  $\overline{\text{OE}}$  maintains PLL lock due to the internal feedback path. The MPC9350 is fully 2.5 V and 3.3 V compatible and requires no external loop filter components. The on-chip crystal oscillator requires no external components beyond a series resonant crystal. All inputs except the crystal oscillator interface accept LVCMOS signals while the outputs provide LVCMOS compatible levels with the capability to drive terminated  $50\ \Omega$  transmission lines. For series terminated transmission lines, each of the MPC9350 outputs can drive one or two traces giving the device an effective fanout of 1:18. The device is packaged in a  $7\times 7\ \text{mm}^2$  32-lead LQFP package.

**MPC9350**

**LOW VOLTAGE  
3.3 V AND 2.5 V PLL  
CLOCK GENERATOR**



**FA SUFFIX  
32-LEAD LQFP PACKAGE  
CASE 873A-03**



**AC SUFFIX  
32-LEAD LQFP PACKAGE  
Pb-FREE PACKAGE  
CASE 873A-03**



**Table 1. Pin Description**

| Number           | Name   | Type            | Description                                       |
|------------------|--------|-----------------|---|
| XTAL1, XTAL2     | Input  | Analog          | Crystal oscillator terminals                      |
| TCLK             | Input  | LVC MOS         | Single ended reference clock signal or test clock |
| FBSEL            | Input  | LVC MOS         | Selects feedback divider ratio                    |
| REF_SEL          | Input  | LVC MOS         | Selects input reference source                    |
| FSELA            | Input  | LVC MOS         | Output A divider selection                        |
| FSELB            | Input  | LVC MOS         | Output B divider selection                        |
| FSELC            | Input  | LVC MOS         | Outputs C divider selection                       |
| FSELD            | Input  | LVC MOS         | Outputs D divider selection                       |
| OE               | Input  | LVC MOS         | Output enable/disable                             |
| QA               | Output | LVC MOS         | Bank A clock output                               |
| QB               | Output | LVC MOS         | Bank B clock output                               |
| QC0, QC1         | Output | LVC MOS         | Bank C clock outputs                              |
| QD0 – QD4        | Output | LVC MOS         | Bank D clock outputs                              |
| GND              | Supply | Ground          | Negative power supply                             |
| V <sub>CCA</sub> | Supply | V <sub>CC</sub> | Positive power supply for the PLL                 |
| V <sub>CC</sub>  | Supply | V <sub>CC</sub> | Positive power supply for I/O and core            |

**Table 2. Function Table**

| Control         | Default | 0  | 1   |
|-----------------|---------|--|---|
| REF_SEL         | 0       | Selects XTAL   | Selects TCLK  |
| PLL_EN          | 1       | Test mode with PLL disabled. The input clock is directly routed to the output dividers | PLL enabled. The VCO output is routed to the output dividers      |
| FBSEL           | 0       | Selects feedback divider ÷ 32<br>VCO = 32 * Input reference clock                      | Selects feedback divider ÷ 16<br>VCO = 16 * Input reference clock |
| $\overline{OE}$ | 0       | Outputs enabled  | Outputs disabled  |
| FSELA           | 0       | QA = VCO ÷ 2   | QA = VCO ÷ 4  |
| FSELB           | 0       | QB = VCO ÷ 4   | QB = VCO ÷ 8  |
| FSELC           | 0       | QC = VCO ÷ 4   | QC = VCO ÷ 8  |
| FSELD           | 0       | QD = VCO ÷ 4   | QD = VCO ÷ 8  |

**Table 3. Absolute Maximum Ratings<sup>(1)</sup>**

| Symbol           | Characteristics     | Min  | Max                  | Unit | Condition |
|------------------|---------------------|------|----------------------|------|-----------|
| V <sub>CC</sub>  | Supply Voltage      | -0.3 | 4.6                  | V    |           |
| V <sub>IN</sub>  | DC Input Voltage    | -0.3 | V <sub>CC</sub> +0.3 | V    |           |
| V <sub>OUT</sub> | DC Output Voltage   | -0.3 | V <sub>CC</sub> +0.3 | V    |           |
| I <sub>IN</sub>  | DC Input Current    |      | ±20                  | mA   |           |
| I <sub>OUT</sub> | DC Output Current   |      | ±50                  | mA   |           |
| T <sub>S</sub>   | Storage temperature | -40  | 125                  | °C   |           |

1. Absolute maximum continuous ratings are those maximum values beyond which damage to the device may occur. Exposure to these conditions or conditions beyond those indicated may adversely affect device reliability. Functional operation under absolute-maximum-rated conditions is not implied.

**Table 4. DC Characteristics** ( $V_{CC} = 3.3\text{ V} \pm 5\%$ ,  $T_A = -40^\circ$  to  $85^\circ\text{C}$ )

| Symbol    | Characteristics                  | Min  | Typ             | Max            | Unit          | Condition  |
|-----------|----------------------------------|------|-----------------|----------------|---------------|--|
| $V_{IH}$  | Input high voltage               | 2.0  |                 | $V_{CC} + 0.3$ | V             | LVC MOS  |
| $V_{IL}$  | Input low voltage                | -0.3 |                 | 0.8            | V             | LVC MOS  |
| $V_{OH}$  | Output High Voltage              | 2.4  |                 |                | V             | $I_{OH} = -24\text{ mA}^{(1)}$                     |
| $V_{OL}$  | Output Low Voltage               |      |                 | 0.55<br>0.30   | V<br>V        | $I_{OL} = 24\text{ mA}$<br>$I_{OL} = 12\text{ mA}$ |
| $I_{IN}$  | Input Current                    |      |                 | 200            | $\mu\text{A}$ | $V_{IN} = 0\text{ V}$ or $V_{IN} = V_{CC}$         |
| $Z_{OUT}$ | Output impedance                 |      | 14 – 17         |                | $\Omega$      |  |
| $C_{IN}$  | Input capacitance                |      | 4.0             |                | pF            |  |
| $C_{PD}$  | Power Dissipation Capacitance    |      | 10              |                | pF            | Per Output   |
| $I_{CCA}$ | Maximum PLL Supply Current       |      |                 | 10             | mA            | $V_{CCA}$ Pin                                      |
| $I_{CC}$  | Maximum Quiescent Supply Current |      |                 | 1.0            | mA            | All $V_{CC}$ Pins                                  |
| $V_{TT}$  | Output termination voltage       |      | $V_{CC} \div 2$ |                | V             |  |

1. The MPC9350 is capable of driving  $50\ \Omega$  transmission lines on the incident edge. Each output drives one  $50\ \Omega$  parallel terminated transmission line to a termination voltage of  $V_{TT}$ . Alternatively, the device drives up to two  $50\ \Omega$  series terminated transmission lines.

**Table 5. AC Characteristics** ( $V_{CC} = 3.3\text{ V} \pm 5\%$  or  $V_{CC} = 2.5\text{ V} \pm 5\%$ ,  $T_A = -40^\circ$  to  $85^\circ\text{C}$ )<sup>(1)</sup>

| Symbol                 | Characteristics  | Min | Typ    | Max               | Unit                     | Condition                            |
|------------------------|--|-----|--------|-------------------|--------------------------|--------------------------------------|
| $f_{ref}$              | Input Frequency<br><div style="display: flex; justify-content: space-between; margin-left: 100px;"> <span><math>\div 16</math> feedback</span> <span>12.5</span> </div> <div style="display: flex; justify-content: space-between; margin-left: 100px;"> <span><math>\div 32</math> feedback</span> <span>6.25</span> </div> Static Test Mode<br><div style="display: flex; justify-content: space-between; margin-left: 100px;"> <span></span> <span>0</span> </div>  |     |        | 25<br>12.5<br>300 | MHz<br>MHz<br>MHz        | FBSEL = 1<br>FBSEL = 0<br>PLL_EN = 0 |
| $f_{XTAL}$             | Crystal Oscillator Frequency   | 10  |        | 25                | MHz                      | XTAL inputs                          |
| $f_{VCO}$              | VCO Frequency  | 200 |        | 400               | MHz                      | PLL_EN = 1                           |
| $f_{MAX}$              | Maximum Output Frequency<br><div style="display: flex; justify-content: space-between; margin-left: 100px;"> <span><math>\div 2</math> output</span> <span>100</span> </div> <div style="display: flex; justify-content: space-between; margin-left: 100px;"> <span><math>\div 4</math> output</span> <span>50</span> </div> <div style="display: flex; justify-content: space-between; margin-left: 100px;"> <span><math>\div 8</math> output</span> <span>25</span> </div>   |     |        | 200<br>100<br>50  | MHz<br>MHz<br>MHz        |                                      |
| $f_{refDC}$            | Reference Input Duty Cycle   | 25  |        | 75                | %                        |                                      |
| $t_r, t_f$             | TLCK Input Rise/Fall Time<br><div style="display: flex; justify-content: space-between; margin-left: 100px;"> <span><math>V_{CC} = 2.5\text{ V}</math></span> <span></span> </div> <div style="display: flex; justify-content: space-between; margin-left: 100px;"> <span><math>V_{CC} = 3.3\text{ V}</math></span> <span></span> </div>   |     |        | 1.0<br>1.0        | ns<br>ns                 | 0.7 V to 1.7 V<br>0.8 V to 2.0 V     |
| $t_{sk(o)}$            | Output-to-output Skew  |     | 45     | 150               | ps                       |                                      |
| $t_{PW}$               | Output Duty Cycle  | 45  | 50     | 55                | ps                       | T=Clock period                       |
| $t_r, t_f$             | Output Rise/Fall Time  | 0.1 | 0.5    | 1.0               | ns                       | see <a href="#">Figure 10</a>        |
| $t_{PLZ, HZ}$          | Output Disable Time  |     |        | 10                | ns                       |                                      |
| $t_{PZL, LZ}$          | Output Enable Time   |     |        | 10                | ns                       |                                      |
| BW                     | PLL closed loop bandwidth<br><div style="display: flex; justify-content: space-between; margin-left: 100px;"> <span><math>\div 16</math> feedback (<math>V_{CC} = 3.3\text{ V}</math>)</span> <span>2.0 – 8.0</span> </div> <div style="display: flex; justify-content: space-between; margin-left: 100px;"> <span><math>\div 16</math> feedback (<math>V_{CC} = 2.5\text{ V}</math>)</span> <span>1.0 – 4.0</span> </div> <div style="display: flex; justify-content: space-between; margin-left: 100px;"> <span><math>\div 32</math> feedback (<math>V_{CC} = 3.3\text{ V}</math>)</span> <span>1.5 – 3.5</span> </div> <div style="display: flex; justify-content: space-between; margin-left: 100px;"> <span><math>\div 32</math> feedback (<math>V_{CC} = 2.5\text{ V}</math>)</span> <span>0.7 – 2.0</span> </div> |     |        |                   | MHz<br>MHz<br>MHz<br>MHz |                                      |
| $t_{JIT(CC)}$          | Cycle-to-cycle jitter<br><div style="display: flex; justify-content: space-between; margin-left: 100px;"> <span>single frequency</span> <span>30</span> </div> <div style="display: flex; justify-content: space-between; margin-left: 100px;"> <span>multiple frequencies</span> <span>100</span> </div>  |     |        | 200<br>300        | ps<br>ps                 |                                      |
| $t_{JIT(PER)}$         | Period Jitter<br><div style="display: flex; justify-content: space-between; margin-left: 100px;"> <span><math>\div 16</math> feedback</span> <span>30</span> </div> <div style="display: flex; justify-content: space-between; margin-left: 100px;"> <span><math>\div 32</math> feedback</span> <span>80</span> </div>   |     |        | 150<br>200        | ps<br>ps                 |                                      |
| $t_{LOCK}$             | Maximum PLL Lock Time  |     |        | 1                 | ms                       |                                      |
| $t_{JIT(\varnothing)}$ | I/O Phase Jitter (RMS)   |     | 5 – 20 |                   | ps                       | RMS value                            |

1. AC characteristics apply for parallel output termination of  $50\ \Omega$  to  $V_{TT}$ .

**Table 6. DC Characteristics** ( $V_{CC} = 2.5\text{ V} \pm 5\%$ ,  $T_A = -40^\circ$  to  $85^\circ\text{C}$ )

| Symbol    | Characteristics                  | Min  | Typ            | Max            | Unit          | Condition                                  |
|-----------|----------------------------------|------|----------------|----------------|---------------|--|
| $V_{IH}$  | Input high voltage               | 1.7  |                | $V_{CC} + 0.3$ | V             | LVC MOS                                    |
| $V_{IL}$  | Input low voltage                | -0.3 |                | 0.7            | V             | LVC MOS                                    |
| $V_{OH}$  | Output High Voltage              | 1.8  |                |                | V             | $I_{OH} = -15\text{ mA}^{(1)}$             |
| $V_{OL}$  | Output Low Voltage               |      |                | 0.6            | V             | $I_{OL} = 15\text{ mA}$                    |
| $Z_{OUT}$ | Output impedance                 |      | 17 – 20        |                | $\Omega$      |  |
| $I_{IN}$  | Input Current                    |      |                | 200            | $\mu\text{A}$ | $V_{IN} = 0\text{ V}$ or $V_{IN} = V_{CC}$ |
| $C_{IN}$  | Input capacitance                |      | 4.0            |                | pF            |  |
| $C_{PD}$  | Power Dissipation Capacitance    |      | 10             |                | pF            | Per Output                                 |
| $I_{CCA}$ | Maximum PLL Supply Current       |      |                | 10             | mA            | $V_{CCA}$ Pin                              |
| $I_{CC}$  | Maximum Quiescent Supply Current |      |                | 1.0            | mA            | All $V_{CC}$ Pins                          |
| $V_{TT}$  | Output termination voltage       |      | $V_{CC} \pm 2$ |                | V             |  |

1. The MPC9350 is capable of driving  $50\ \Omega$  transmission lines on the incident edge. Each output drives one  $50\ \Omega$  parallel terminated transmission line to a termination voltage of  $V_{TT}$ . Alternatively, the device drives up to two  $50\ \Omega$  series terminated transmission lines per output.

## APPLICATIONS INFORMATION

### Programming the MPC9350

The MPC9350 clock driver outputs can be configured into several divider modes. In addition, the internal feedback of the device allows for flexibility in establishing two input to output frequency relationships. The output division settings establish the output frequency relationship. The output divider of the four output groups allows the user to configure the outputs into 1:1, 2:1, 4:1 and 4:2:1 frequency ratios. The use of even dividers ensures that the output duty cycle is always 50%. [Table 7](#) and [Table 8](#) illustrate the various output

configurations. The tables describe the outputs using the input clock frequency CLK as a reference.

In addition, it must be ensured that the VCO will be stable given the frequency of the outputs desired. The feedback frequency should be used to situate the VCO into a frequency range in which the PLL will be stable. The design of the PLL supports output frequencies from 25 MHz to 200 MHz while the VCO frequency range is specified from 200 MHz to 400 MHz and should not be exceeded for stable operation.

**Table 7. Output Frequency Relationship<sup>(1)</sup> FBSEL = 0, (VC0 = 32 \* CLK)**

| Inputs |       |       |       | Outputs  |         |          |         |
|--------|-------|-------|-------|----------|---------|----------|---------|
| FSELA  | FSELB | FSELC | FSELD | QA       | QB      | QC0, QC1 | QD0–QD4 |
| 0      | 0     | 0     | 0     | 16 * CLK | 8 * CLK | 8 * CLK  | 8 * CLK |
| 0      | 0     | 0     | 1     | 16 * CLK | 8 * CLK | 8 * CLK  | 4 * CLK |
| 0      | 0     | 1     | 0     | 16 * CLK | 8 * CLK | 4 * CLK  | 8 * CLK |
| 0      | 0     | 1     | 1     | 16 * CLK | 8 * CLK | 4 * CLK  | 4 * CLK |
| 0      | 1     | 0     | 0     | 16 * CLK | 4 * CLK | 8 * CLK  | 8 * CLK |
| 0      | 1     | 0     | 1     | 16 * CLK | 4 * CLK | 8 * CLK  | 4 * CLK |
| 0      | 1     | 1     | 0     | 16 * CLK | 4 * CLK | 4 * CLK  | 8 * CLK |
| 0      | 1     | 1     | 1     | 16 * CLK | 4 * CLK | 4 * CLK  | 4 * CLK |
| 1      | 0     | 0     | 0     | 8 * CLK  | 8 * CLK | 8 * CLK  | 8 * CLK |
| 1      | 0     | 0     | 1     | 8 * CLK  | 8 * CLK | 8 * CLK  | 4 * CLK |
| 1      | 0     | 1     | 0     | 8 * CLK  | 8 * CLK | 4 * CLK  | 8 * CLK |
| 1      | 0     | 1     | 1     | 8 * CLK  | 8 * CLK | 4 * CLK  | 4 * CLK |
| 1      | 1     | 0     | 0     | 8 * CLK  | 4 * CLK | 8 * CLK  | 8 * CLK |
| 1      | 1     | 0     | 1     | 8 * CLK  | 4 * CLK | 8 * CLK  | 4 * CLK |
| 1      | 1     | 1     | 0     | 8 * CLK  | 4 * CLK | 4 * CLK  | 8 * CLK |
| 1      | 1     | 1     | 1     | 8 * CLK  | 4 * CLK | 4 * CLK  | 4 * CLK |

1. Output frequency relationship with respect to input reference frequency CLK. Consult the MPC9351 data sheet for more input to output relationships in external feedback mode.

**Table 8. Output Frequency Relationship<sup>(1)</sup> FBSEL = 1, (VC0 = 16 \* CLK)**

| Inputs |       |       |       | Outputs |         |          |         |
|--------|-------|-------|-------|---------|---------|----------|---------|
| FSELA  | FSELB | FSELC | FSELD | QA      | QB      | QC0, QC1 | QD0–QD4 |
| 0      | 0     | 0     | 0     | 8 * CLK | 4 * CLK | 4 * CLK  | 4 * CLK |
| 0      | 0     | 0     | 1     | 8 * CLK | 4 * CLK | 4 * CLK  | 2 * CLK |
| 0      | 0     | 1     | 0     | 8 * CLK | 4 * CLK | 2 * CLK  | 4 * CLK |
| 0      | 0     | 1     | 1     | 8 * CLK | 4 * CLK | 2 * CLK  | 2 * CLK |
| 0      | 1     | 0     | 0     | 8 * CLK | 2 * CLK | 4 * CLK  | 4 * CLK |
| 0      | 1     | 0     | 1     | 8 * CLK | 2 * CLK | 4 * CLK  | 2 * CLK |
| 0      | 1     | 1     | 0     | 8 * CLK | 2 * CLK | 2 * CLK  | 4 * CLK |
| 0      | 1     | 1     | 1     | 8 * CLK | 2 * CLK | 2 * CLK  | 2 * CLK |
| 1      | 0     | 0     | 0     | 4 * CLK | 4 * CLK | 4 * CLK  | 4 * CLK |
| 1      | 0     | 0     | 1     | 4 * CLK | 4 * CLK | 4 * CLK  | 2 * CLK |
| 1      | 0     | 1     | 0     | 4 * CLK | 4 * CLK | 2 * CLK  | 4 * CLK |
| 1      | 0     | 1     | 1     | 4 * CLK | 4 * CLK | 2 * CLK  | 2 * CLK |
| 1      | 1     | 0     | 0     | 4 * CLK | 2 * CLK | 4 * CLK  | 4 * CLK |
| 1      | 1     | 0     | 1     | 4 * CLK | 2 * CLK | 4 * CLK  | 2 * CLK |
| 1      | 1     | 1     | 0     | 4 * CLK | 2 * CLK | 2 * CLK  | 4 * CLK |
| 1      | 1     | 1     | 1     | 4 * CLK | 2 * CLK | 2 * CLK  | 2 * CLK |

1. Output frequency relationship with respect to input reference frequency CLK. Consult the MPC9351 data sheet for more input to output relationships in external feedback mode.

## Power Supply Filtering

The MPC9350 is a mixed analog/digital product and as such, it exhibits some sensitivities that would not necessarily be seen on a fully digital product. Analog circuitry is naturally susceptible to random noise, especially if this noise is seen on the power supply pins. The MPC9350 provides separate power supplies for the output buffers ( $V_{CCO}$ ) and the phase-locked loop ( $V_{CCA}$ ) of the device.

The purpose of this design technique is to try and isolate the high switching noise digital outputs from the relatively sensitive internal analog phase-locked loop. In a controlled environment such as an evaluation board, this level of isolation is sufficient; however, in a digital system environment where it is more difficult to minimize noise on the power supplies, a second level of isolation may be required. The simplest form of isolation is a power supply filter on the  $V_{CCA}$  pin for the MPC9350. Figure 3 illustrates a typical power supply filter scheme. The MPC9350 is most susceptible to noise with spectral content in the 10 kHz to 5 MHz range; therefore, the filter should be designed to target this range. The key parameter that needs to be met in the final filter design is the DC voltage drop that will be seen between the  $V_{CC}$  supply and the  $V_{CCA}$  pin of the MPC9350. From the data sheet the  $I_{VCCA}$  current (the current sourced through the  $V_{CCA}$  pin) is typically 10 mA (15 mA maximum), assuming that a minimum of 3.0 V must be maintained on the  $V_{CCA}$  pin. Very little DC voltage drop can be tolerated when a 3.3 V  $V_{CC}$  supply is used. The resistor shown in Figure 3 must have a resistance of 10–15  $\Omega$  to meet the voltage drop criteria for  $V_{CC} = 3.3$  V. For  $V_{CC} = 2.5$  V operation,  $R_S$  must be selected to maintain the minimum  $V_{CC}$  specification of 2.375 V for the PLL supply pin for proper operation. The RC filter pictured will provide a broadband filter with approximately 100:1 attenuation for noise whose spectral content is above 20 kHz. As the noise frequency crosses the series resonant point of an individual capacitor, its overall impedance begins to look inductive and, thus, increases with increasing frequency. The parallel capacitor combination shown ensures that a low impedance path to ground exists for frequencies well above the bandwidth of the PLL. It is recommended that the user start with an 8–10  $\Omega$  resistor to avoid potential  $V_{CC}$  drop problems and only move to the higher value resistors when a higher level of attenuation is shown to be needed.

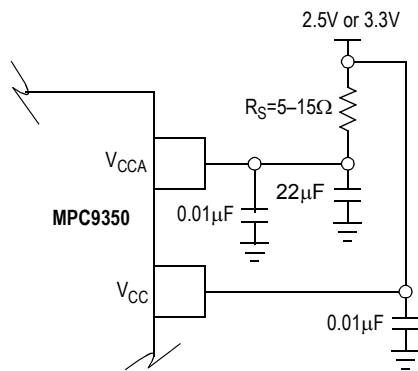

Figure 3. Power Supply Filter

Although the MPC9350 has several design features to minimize the susceptibility to power supply noise (isolated power and grounds and fully differential PLL) there still may be applications in which overall performance is being degraded due to system power supply noise. The power supply filter schemes discussed in this section should be adequate to eliminate power supply noise related problems in most designs.

## Driving Transmission Lines

The MPC9350 clock driver was designed to drive high-speed signals in a terminated transmission line environment. To provide the optimum flexibility to the user, the output drivers were designed to exhibit the lowest impedance possible. With an output impedance of less than 15  $\Omega$ , the drivers can drive either parallel or series terminated transmission lines. For more information on transmission lines the reader is referred to Freescale application note AN1091. In most high performance clock networks, point-to-point distribution of signals is the method of choice. In a point-to-point scheme, either series terminated or parallel terminated transmission lines can be used. The parallel technique terminates the signal at the end of the line with a 50  $\Omega$  resistance to  $V_{CC} \div 2$ .

This technique draws a fairly high level of DC current, and thus, only a single terminated line can be driven by each output of the MPC9350 clock driver. For the series terminated case, however, there is no DC current draw, thus the outputs can drive multiple series terminated lines. Figure 4 illustrates an output driving a single series terminated line versus two series terminated lines in parallel. When taken to its extreme, the fanout of the MPC9350 clock driver is effectively doubled due to its capability to drive multiple lines.

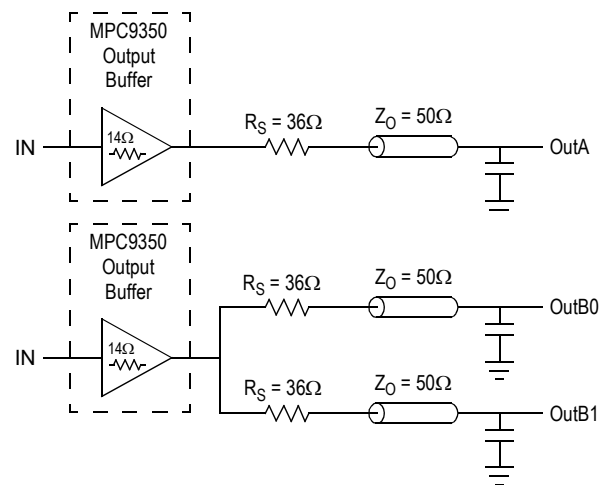

Figure 4. Single versus Dual Transmission Lines

The waveform plots in Figure 5 show the simulation results of an output driving a single line versus two lines. In both cases, the drive capability of the MPC9350 output buffer is more than sufficient to drive 50  $\Omega$  transmission lines on the incident edge. Note from the delay measurements in the simulations, a delta of only 43 ps exists between the two differently loaded outputs. This suggests that the dual line driving need not be used exclusively to maintain the tight

output-to-output skew of the MPC9350. The output waveform in Figure 5 shows a step in the waveform. This step is caused by the impedance mismatch seen looking into the driver. The parallel combination of the 36 Ω series resistor plus the output impedance does not match the parallel combination of the line impedances. The voltage wave launched down the two lines will equal:

$$V_L = V_S (Z_0 \div (R_S + R_0 + Z_0))$$

$$Z_0 = 50 \Omega \parallel 50 \Omega$$

$$R_S = 36 \Omega \parallel 36 \Omega$$

$$R_0 = 17 \Omega$$

$$V_L = 3.0 (25 \div (18 + 17 + 25))$$

$$= 1.25 \text{ V}$$

At the load end the voltage will double, due to the near unity reflection coefficient, to 2.5 V. It will then increment toward the quiescent 3.0 V in steps separated by one round trip delay (in this case 4.0 ns).

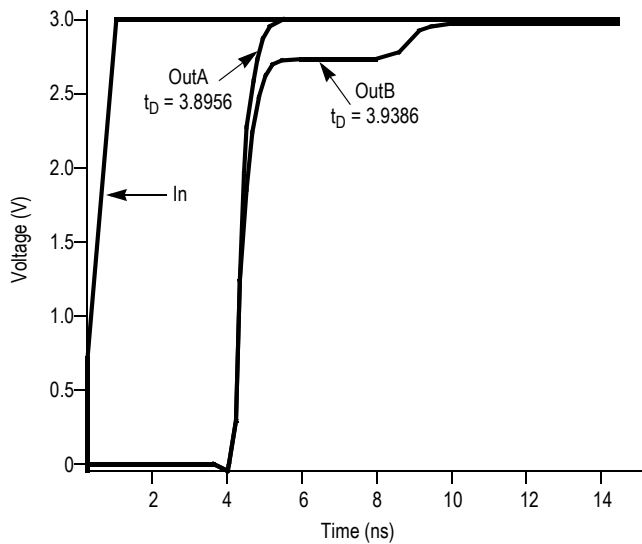

Figure 5. Single versus Dual Waveforms

Since this step is well above the threshold region, it will not cause any false clock triggering; however, designers may be uncomfortable with unwanted reflections on the line. To better match the impedances when driving multiple lines, the situation in Figure 6 should be used. In this case the series terminating resistors are reduced such that when the parallel combination is added to the output buffer impedance, the line impedance is perfectly matched.

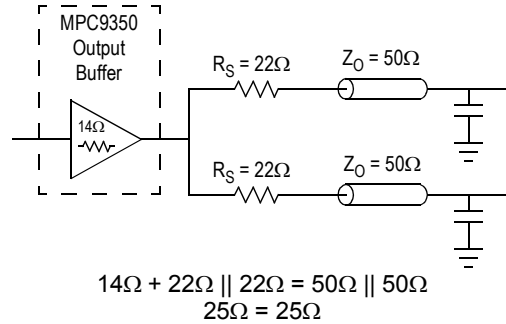

Figure 6. Optimized Dual Line Termination

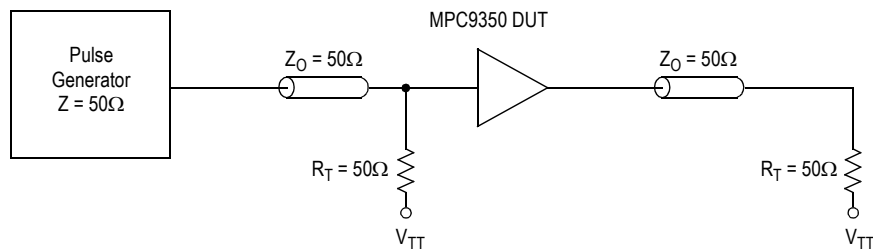
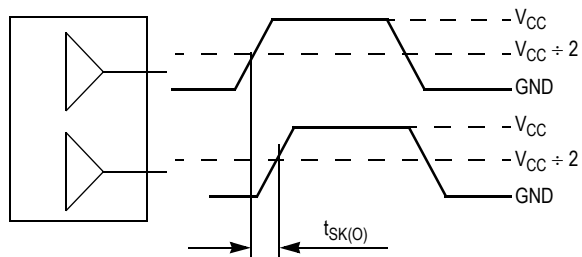

Figure 7. TCLK MPC9350 AC Test Reference for  $V_{CC} = 3.3 \text{ V}$  and  $V_{CC} = 2.5 \text{ V}$





The pin-to-pin skew is defined as the worst case difference in propagation delay between any similar delay path within a single device.

**Figure 8. Output-to-Output Skew  $t_{SK(O)}$**

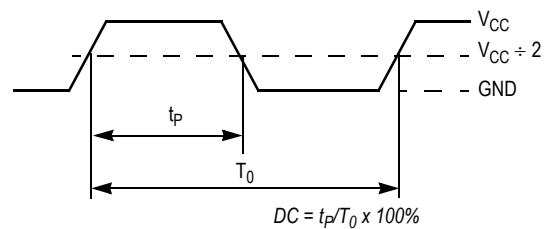

The time from the PLL controlled edge to the non controlled edge, divided by the time between PLL controlled edges, expressed as a percentage.

**Figure 9. Output Duty Cycle (DC)**

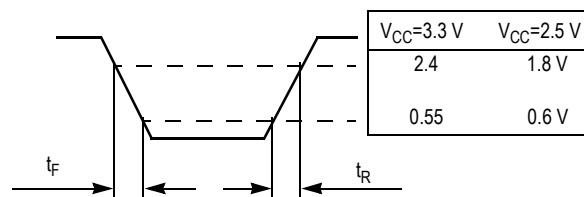

The time from the maximum low level voltage to minimum high level of a clock signal, expressed in ns.

**Figure 10. Transition Time Test Reference**

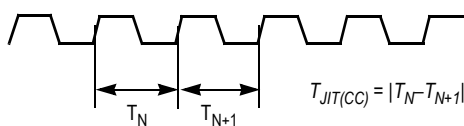

The variation in cycle time of a signal between adjacent cycles, over a random sample of adjacent cycle pairs.

**Figure 11. Cycle-to-Cycle Jitter**

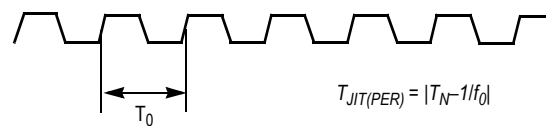

The deviation in cycle time of a signal with respect to the ideal period over a random sample of cycles.

**Figure 12. Period Jitter**

# PACKAGE DIMENSIONS

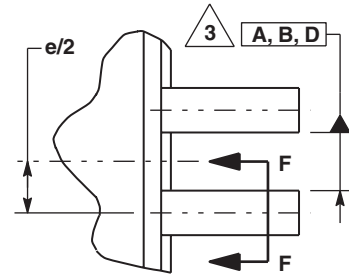
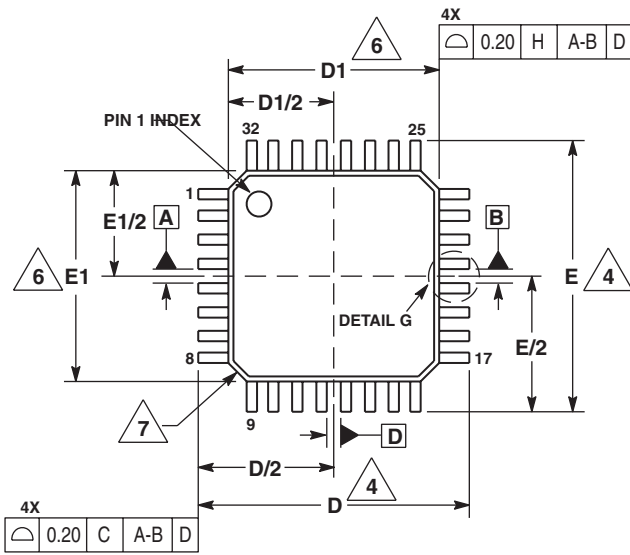

DETAIL G

- NOTES:
1. DIMENSIONS ARE IN MILLIMETERS.
  2. INTERPRET DIMENSIONS AND TOLERANCES PER ASME Y14.5M, 1994.
  3. DATUMS A, B, AND D TO BE DETERMINED AT DATUM PLANE H.
  4. DIMENSIONS D AND E TO BE DETERMINED AT SEATING PLANE C.
  5. DIMENSION b DOES NOT INCLUDE DAMBAR PROTRUSION. ALLOWABLE DAMBAR PROTRUSION SHALL NOT CAUSE THE LEAD WIDTH TO EXCEED THE MAXIMUM b DIMENSION BY MORE THAN 0.08-mm. DAMBAR CANNOT BE LOCATED ON THE LOWER RADIUS OR THE FOOT. MINIMUM SPACE BETWEEN PROTRUSION AND ADJACENT LEAD OR PROTRUSION: 0.07-mm.
  6. DIMENSIONS D1 AND E1 DO NOT INCLUDE MOLD PROTRUSION. ALLOWABLE PROTRUSION IS 0.25-mm PER SIDE. D1 AND E1 ARE MAXIMUM PLASTIC BODY SIZE DIMENSIONS INCLUDING MOLD MISMATCH.
  7. EXACT SHAPE OF EACH CORNER IS OPTIONAL.
  8. THESE DIMENSIONS APPLY TO THE FLAT SECTION OF THE LEAD BETWEEN 0.1-mm AND 0.25-mm FROM THE LEAD TIP.

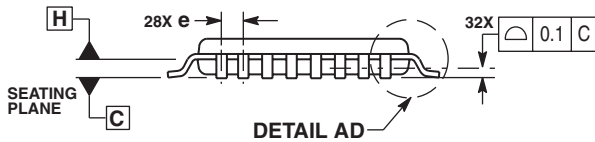

DETAIL AD

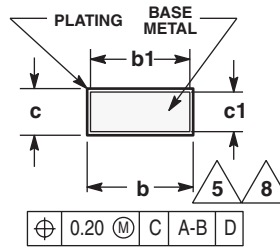

SECTION F-F

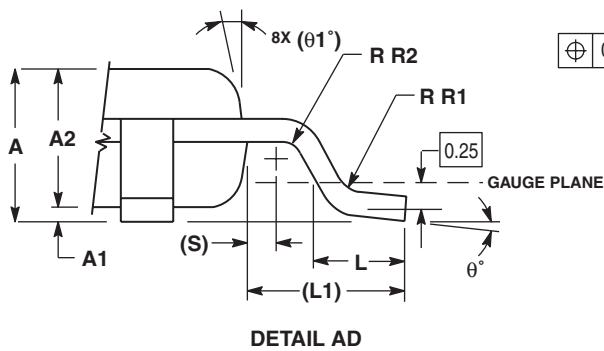

DETAIL AD

| DIM | MILLIMETERS |      |
|-----|-------------|------|
|     | MIN         | MAX  |
| A   | 1.40        | 1.60 |
| A1  | 0.05        | 0.15 |
| A2  | 1.35        | 1.45 |
| b   | 0.30        | 0.45 |
| b1  | 0.30        | 0.40 |
| c   | 0.09        | 0.20 |
| c1  | 0.09        | 0.16 |
| D   | 9.00 BSC    |      |
| D1  | 7.00 BSC    |      |
| e   | 0.80 BSC    |      |
| E   | 9.00 BSC    |      |
| E1  | 7.00 BSC    |      |
| L   | 0.50        | 0.70 |
| L1  | 1.00 REF    |      |
| q   | 0°          | 7°   |
| q1  | 12 REF      |      |
| R1  | 0.08        | 0.20 |
| R2  | 0.08        | ---  |
| S   | 0.20 REF    |      |

**CASE 873A-03  
ISSUE B  
32-LEAD LQFP PACKAGE**

---

# NOTES

## **How to Reach Us:**

### **Home Page:**

[www.freescale.com](http://www.freescale.com)

### **E-mail:**

[support@freescale.com](mailto:support@freescale.com)

### **USA/Europe or Locations Not Listed:**

Freescale Semiconductor  
Technical Information Center, CH370  
1300 N. Alma School Road  
Chandler, Arizona 85224  
+1-800-521-6274 or +1-480-768-2130  
[support@freescale.com](mailto:support@freescale.com)

### **Europe, Middle East, and Africa:**

Freescale Halbleiter Deutschland GmbH  
Technical Information Center  
Schatzbogen 7  
81829 Muenchen, Germany  
+44 1296 380 456 (English)  
+46 8 52200080 (English)  
+49 89 92103 559 (German)  
+33 1 69 35 48 48 (French)  
[support@freescale.com](mailto:support@freescale.com)

### **Japan:**

Freescale Semiconductor Japan Ltd.  
Headquarters  
ARCO Tower 15F  
1-8-1, Shimo-Meguro, Meguro-ku,  
Tokyo 153-0064  
Japan  
0120 191014 or +81 3 5437 9125  
[support.japan@freescale.com](mailto:support.japan@freescale.com)

### **Asia/Pacific:**

Freescale Semiconductor Hong Kong Ltd.  
Technical Information Center  
2 Dai King Street  
Tai Po Industrial Estate  
Tai Po, N.T., Hong Kong  
+800 2666 8080  
[support.asia@freescale.com](mailto:support.asia@freescale.com)

### **For Literature Requests Only:**

Freescale Semiconductor Literature Distribution Center  
P.O. Box 5405  
Denver, Colorado 80217  
1-800-441-2447 or 303-675-2140  
Fax: 303-675-2150  
[LDCForFreescaleSemiconductor@hibbertgroup.com](mailto:LDCForFreescaleSemiconductor@hibbertgroup.com)

Information in this document is provided solely to enable system and software implementers to use Freescale Semiconductor products. There are no express or implied copyright licenses granted hereunder to design or fabricate any integrated circuits or integrated circuits based on the information in this document.

Freescale Semiconductor reserves the right to make changes without further notice to any products herein. Freescale Semiconductor makes no warranty, representation or guarantee regarding the suitability of its products for any particular purpose, nor does Freescale Semiconductor assume any liability arising out of the application or use of any product or circuit, and specifically disclaims any and all liability, including without limitation consequential or incidental damages. "Typical" parameters that may be provided in Freescale Semiconductor data sheets and/or specifications can and do vary in different applications and actual performance may vary over time. All operating parameters, including "Typicals", must be validated for each customer application by customer's technical experts. Freescale Semiconductor does not convey any license under its patent rights nor the rights of others. Freescale Semiconductor products are not designed, intended, or authorized for use as components in systems intended for surgical implant into the body, or other applications intended to support or sustain life, or for any other application in which the failure of the Freescale Semiconductor product could create a situation where personal injury or death may occur. Should Buyer purchase or use Freescale Semiconductor products for any such unintended or unauthorized application, Buyer shall indemnify and hold Freescale Semiconductor and its officers, employees, subsidiaries, affiliates, and distributors harmless against all claims, costs, damages, and expenses, and reasonable attorney fees arising out of, directly or indirectly, any claim of personal injury or death associated with such unintended or unauthorized use, even if such claim alleges that Freescale Semiconductor was negligent regarding the design or manufacture of the part.

Freescale™ and the Freescale logo are trademarks of Freescale Semiconductor, Inc. All other product or service names are the property of their respective owners.

© Freescale Semiconductor, Inc. 2005. All rights reserved.