

AT ALL TIMES WATER RESISTANT CONNECTORS NOT IN USE SHOULD BE COVERED WITH A CONEC WATER RESISTANT CAP OR WATER TIGHT HOOD.

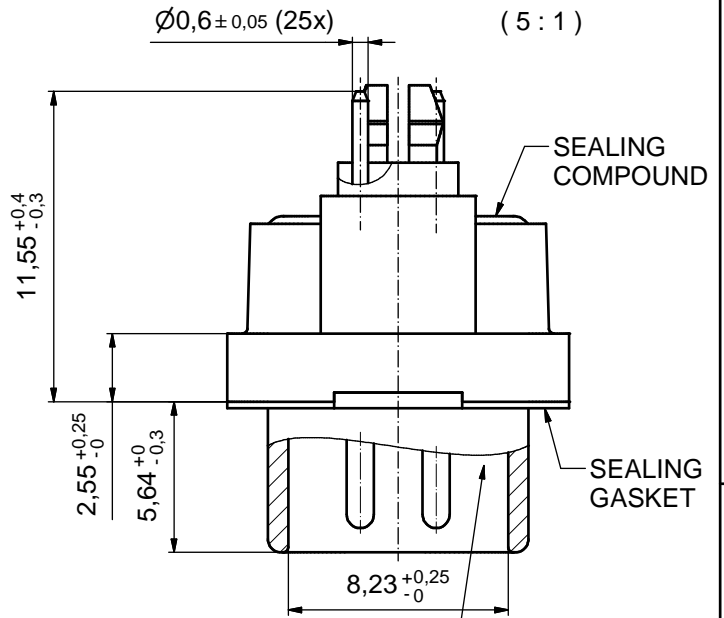

RUBBER GASKET PLACED ON TOP SURFACE OF MALE INSULATOR

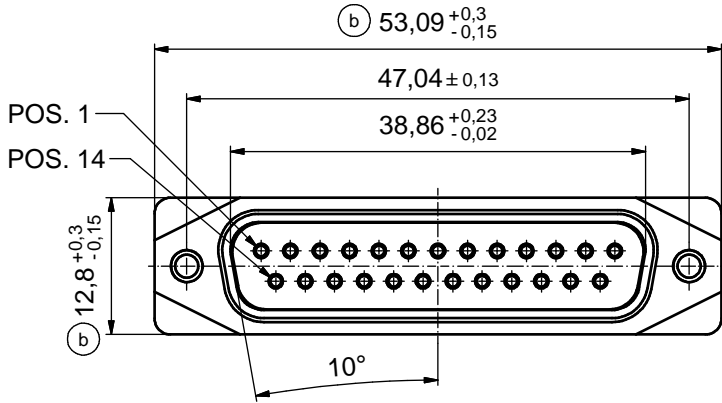
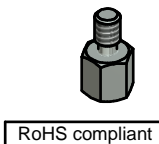
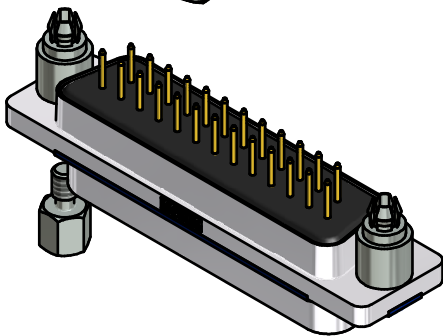
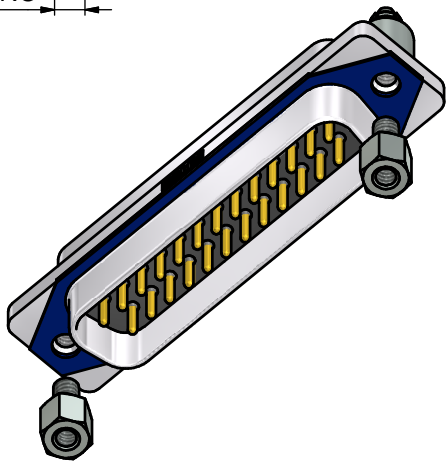
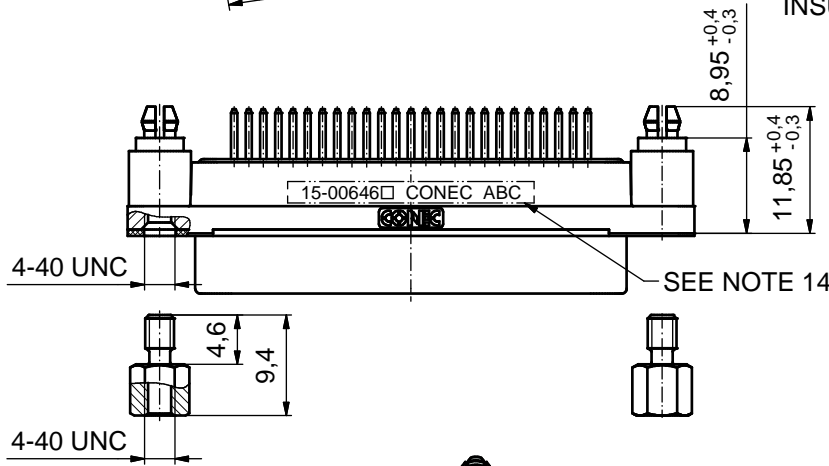

NOTES:

- FOR WAVESOLDERING (SOLDER BATH TEMPERATURE 265°C FOR 8 SEC. AND SOLDER PREHEAT 150°C FOR 180 SEC.)
- IP RATING: IP 67
- SEALED TO WITHSTAND PRESSURE UP TO 1,45 PSI FOR 30 MINUTES AFTER SOLDERING
- METAL SHELL: ZINC DIE CAST; min. 50µm NICKEL PLATING over COPPER
- INSULATORS: PBT GF UL 94 V-0; BLACK
- SEALING GASKET: SILICONE; BLUE
- RUBBER GASKET: TPE; BLACK
- SEALING COMPOUND: EPOXY RESIN UL 94 V-0; BLACK
- CONTACTS: COPPER ALLOY; PLATING (SEE PART-NO.):
□ PLEASE ADD 1 for 30µm HARD GOLD over min. 50µm NICKEL
□ PLEASE ADD 3 for GOLD FLASH over NICKEL
- REAR SPACER CLIPS: COPPER ALLOY; min. 200µm TIN over 80µm NICKEL
PCB-HOLE: $\varnothing 3,1 \pm 0,1$ mm; PCB THICKNESS 1,6mm
- HEXLOCKING SCREWS: STAINLESS STEEL
- P.C.B. HOLE DRILLINGS and RECOMMENDED PANEL CUT-OUT ON SHEET 2
- RECOMMENDED TORQUE FOR MOUNTING SCREW
35Ncm (3.1 in.LB) / max. 67Ncm (6 in.LB)
- CONNECTOR IS PART MARKED: 15-00646 CONEC ABC (see note 9)

THIS DRAWING MAY NOT BE COPIED OR REPRODUCED IN ANY WAY, AND MAY NOT BE PASSED ON TO A THIRD PARTY WITHOUT WRITTEN PERMISSION. OWNERSHIP AND COPYRIGHT OF CONEC GmbH DO NOT ALTER CAD DRAWING BY HAND				tolerance		dim. in mm	scale: 2:1 (5:1)	
				date			material: SEE NOTES	
				drawn	22.09.14	Lehmenkühler		title: D-SUB MALE 25pos. SOLDER PIN STRAIGHT with closed 4-40 UNC thread and rear spacer clip
				appd.	26.01.15	Fischer		
				norm			dwg no:	
1 x c	Ä5827	25.09.15	Unkrüer	d-old			15K1A1547	DIN-A3
2 x b	Ä5800	07.09.15	M.H.					sh: 1
a	Original							
rev.	description	date	name	CONEC		part no: 15-00646 (see note 9)		

P.C.B. HOLE DRILLINGS

(P.C.B. TOP SIDE)

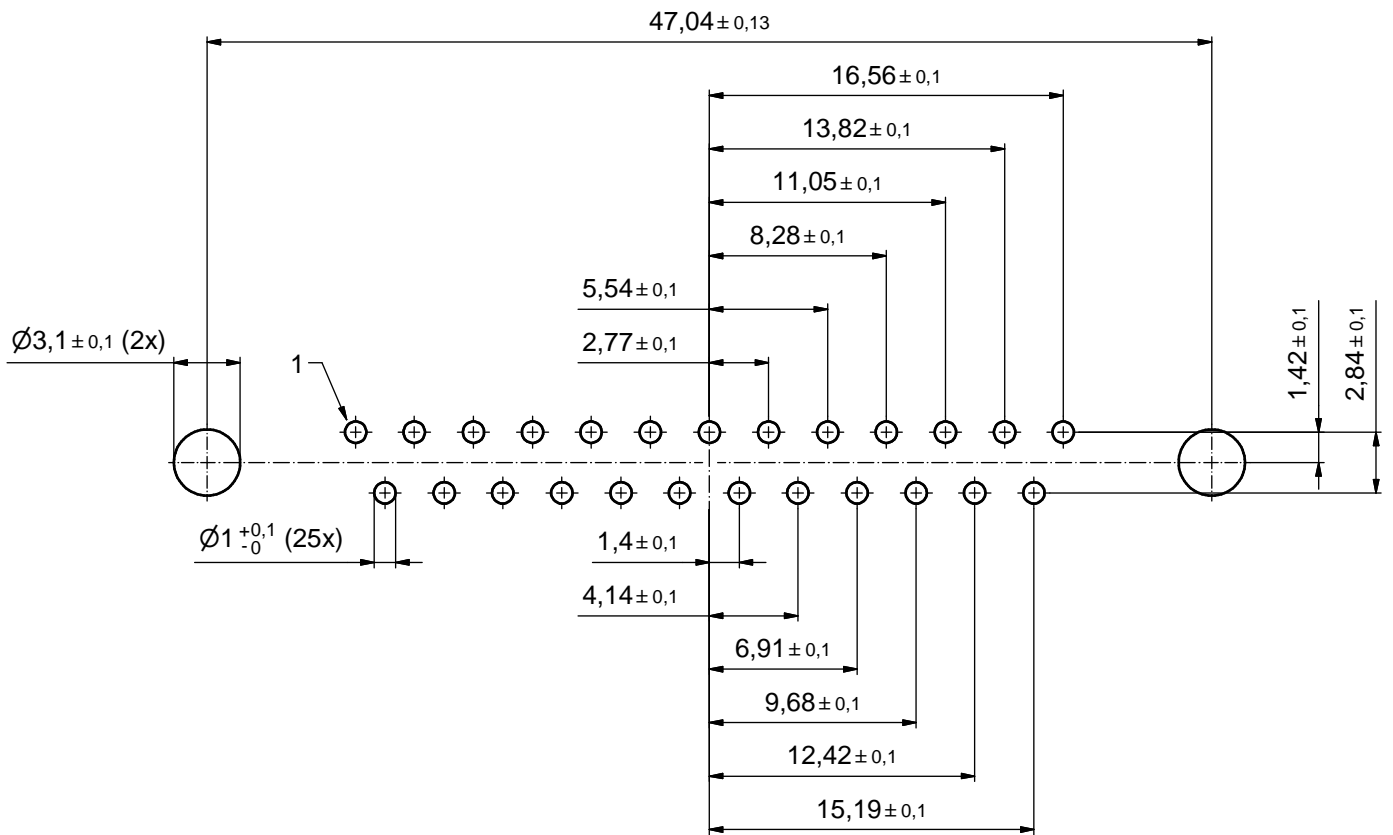

RECOMMENDED PANEL CUT-OUT

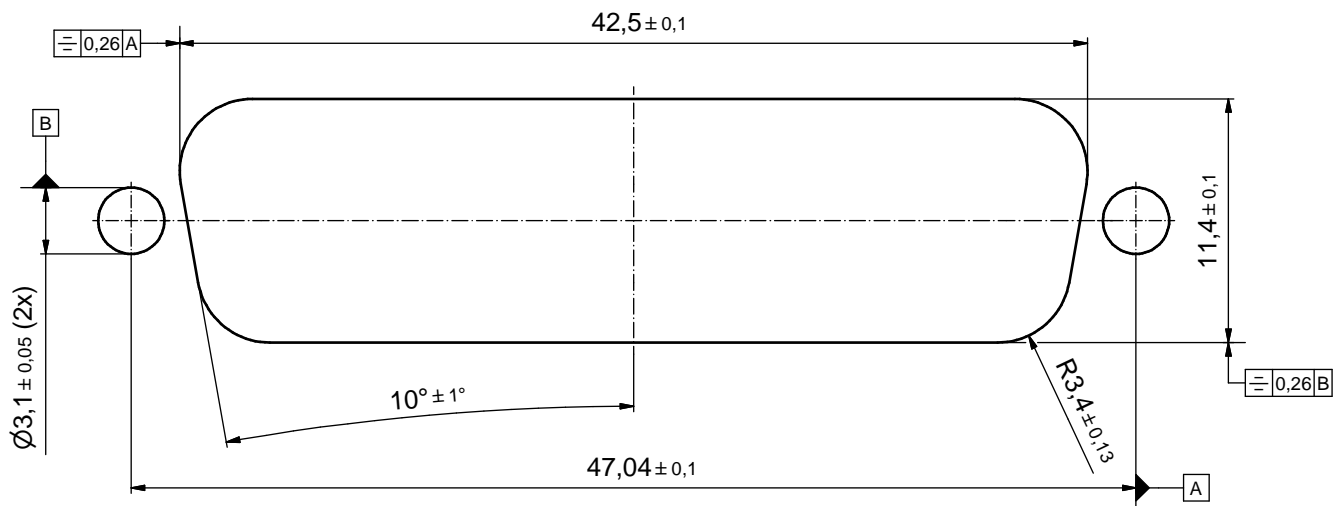

THIS DRAWING MAY NOT BE COPIED OR REPRODUCED IN ANY WAY, AND MAY NOT BE PASSED ON TO A THIRD PARTY WITHOUT WRITTEN PERMISSION. OWNERSHIP AND COPYRIGHT OF CONEC GmbH DO NOT ALTER CAD DRAWING BY HAND				tolerance		scale: 4:1
				dim. in mm		material: SEE SHEET 1
	drawn	22.09.14	Lehmenkühler	date	name	title: P.C.B HOLE DRILLINGS RECOMMENDED PANEL CUT-OUT D-SUB MALE 25pos. SOLDER PIN STRAIGHT
	appd.	26.01.15	Fischer			
	norm					
d-old						
rev.	a	Original				dwg no: 15K1A1547
description						DIN-A3
date						sh: 2
name						part no: SEE SHEET 1

