

SJ025487-E

DWG. NO.

SYM.	DCN NO.	DESCRIPTION	DATE	DRAWN	CHECKED	APP'D	APP'D

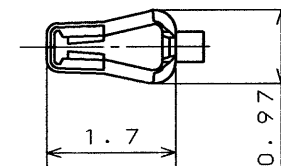
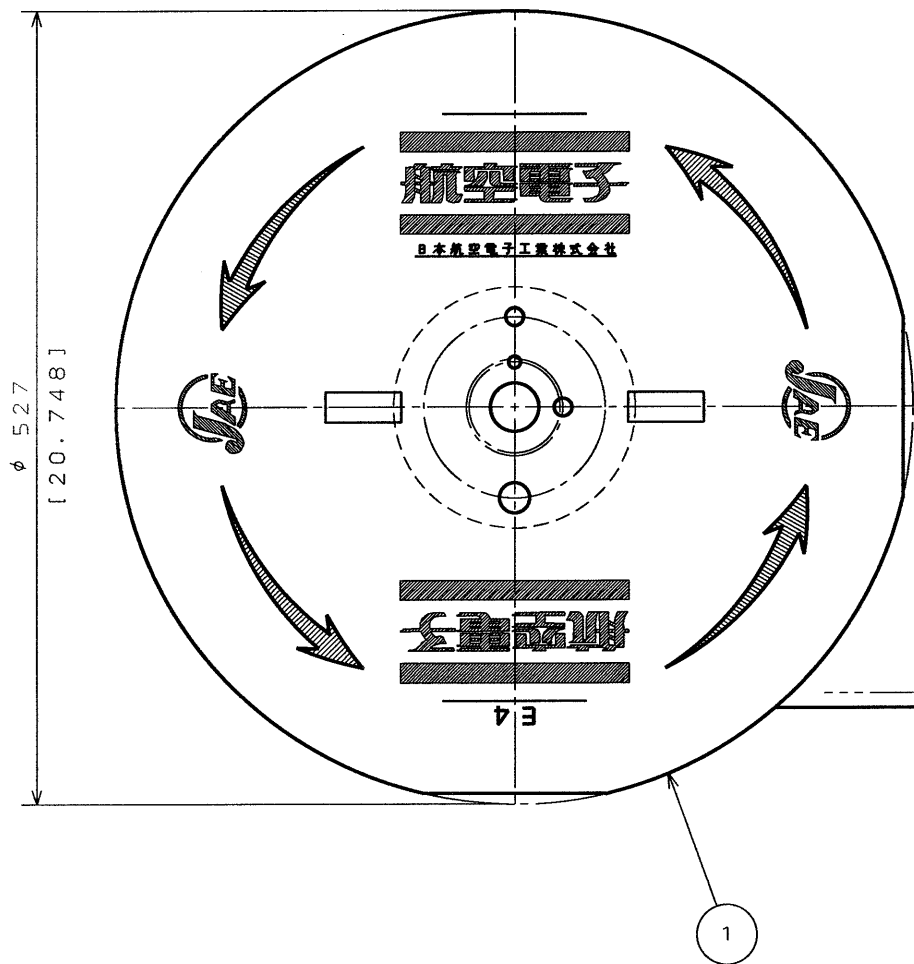
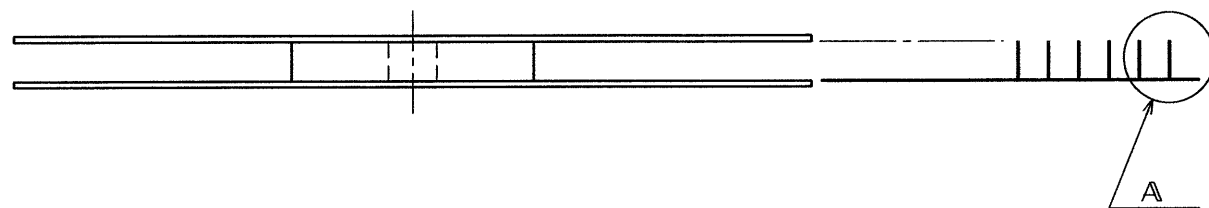

EXCLUDING CRIMP POT

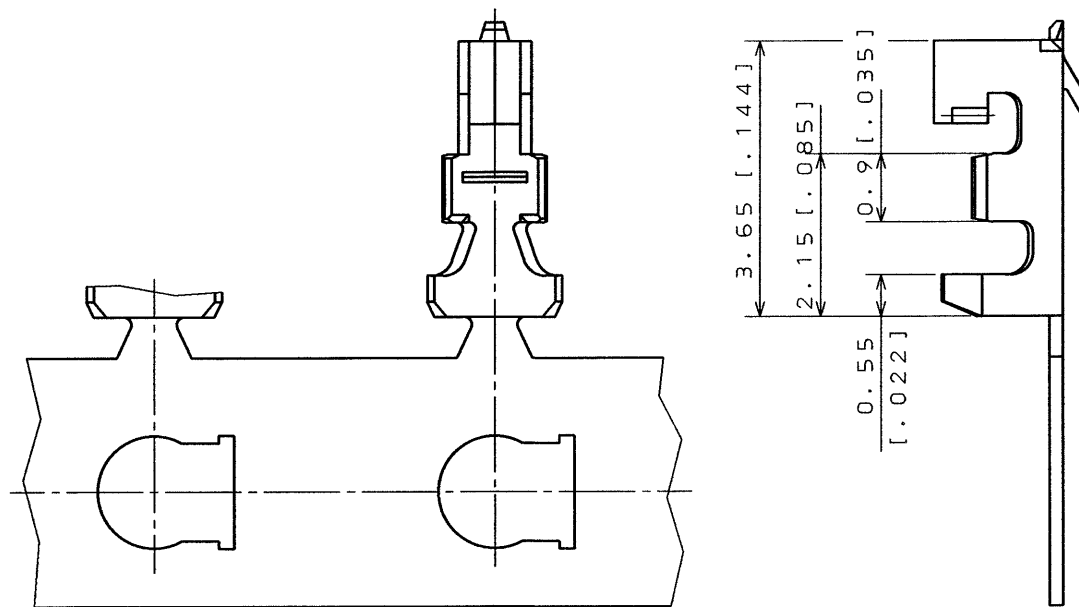

DETAIL A  
(SCALE 10/1)

NOTE 1. APPLICABLE WIRE : AWG#28~#32, STRANDED.  
 APPLICABLE WIRE INSULATION OUTER DIA: 0.5 [.020] ~ 1.0 [.039] mm.

2. APPLICABLE CRIMPING MACHINE FOR THIS  
 MAGAZINE ASS'Y IS CT350-2-ILZ.

ITEM	DESCRIPTION	Q'TY	MATERIAL	FINISH	REMARKS
3	SOCKET CONTACT	15000	PHOSPHOR BRONZE	GOLD OVER KICKEL	Au: 0.1 μm MIN
2	PAPER TEPE	1	PAPER		
1	MAGAGINE	1	PAPER		

REFERENCE DOCUMENT	DATE 3 Jun. '94	SCALE 1:1	WT. 0.1	APPROVAL JAE
MATERIAL	DRAWN H. SAKURADA	TITLE IL-Z-C3-A-1 -15000 (MAGAGINE ASSEMBLY)		
TREATMENT	CHECKED IGARASHI	SERIES IL-Z		
FINISH	APP'D <i>[Signature]</i>	MUSASHINO, AKISHIMA-SHI TOKYO, JAPAN		
DWG. NO. SJ025487-E				SIZE A3

DIMENSIONS ARE IN MILLIMETERS  
 TOLERANCES ON: (INCHES)

DIMENSION	ANGLES	CONCENTRICITY
. ±0.01(.012)	X° ±	WITHIN T.I.R.
.X ±0.01(.008)	X°X' ±	
.XX ±0.11(.004)		
.XXX ±		

DCF-115A



CDS-90-52207

SIZE A3