

© 1973 BY AMP INCORPORATED. ALL RIGHTS RESERVED. AMP PRODUCTS COVERED BY PATENTS AND/OR PATENTS PENDING.

Unpublished copy not to be reproduced without written permission of AMP Incorporated

K	ADDED .712 DIM. FLANGE	10/9/78	M.G.
L	REV PER OH14-0192-05	1-06	PY

REVISIONS				
ZONE	LTR	DESCRIPTION	DATE	APPROVED
	A	REV. 1 REDRAWN	4-2-73	RE Fm
	B	DELETED .872 & ADDED .938	4-4-73	RE Fm
	C	ADDED TIN & GOLD PLATED FLANGES TO -1 & -2	7-13-73	RE Fm
B-2	D	ADDED NOTE -2	1/23/74	M.G.
	E	REV. -2	2/6/74	RE Fm
	F	ADDED .312 DIA., .38, .020, .954, 1.687, ECN 8041, D.S.	5-19-75	M.G.
	G	REMOVED -2	10-14-76	M.G.
	H	.692/.688 WAPS .712	7/18/78	M.G.
C-4	J	ADDED .712 DIA.	9/27/78	M.G.

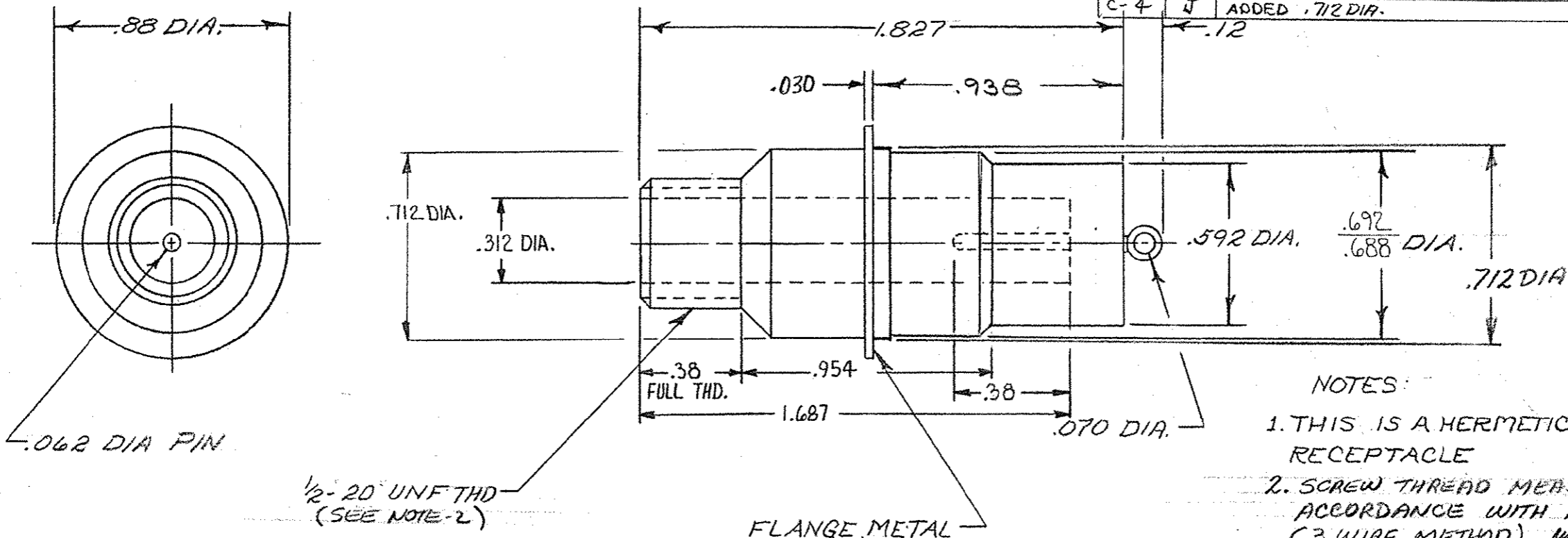

NOTES:  
 1. THIS IS A HERMETICALLY SEALED RECEPTACLE  
 2. SCREW THREAD MEASUREMENT IN ACCORDANCE WITH H28 HANDBOOK. (3 WIRE METHOD). USING WIRE .02887 DIA. - MEASUREMENT OVER WIRE SHALL BE .510/.497

QTY REQD	QTY REQD	ITEM NO.	DWG SIZE	PART OR IDENTIFYING NO.	NOMENCLATURE OR DESCRIPTION	SYMBOL
-2	-1			5-861255-1	TIN PLATED PIN AND FLANGE	WITH MARKING
				861255-1	TIN-LEAD PLATED PIN AND FLANGE	WITH MARKING

UNLESS OTHERWISE SPECIFIED: DIMENSIONS ARE IN INCHES TOLERANCES .00 ± .01 ANGLES ± 1° .000 ± .005				CONTRACT NO. DR 2/27/73		AMP INCORPORATED CAPITRON DIVISION ELIZABETHTOWN, PENNSYLVANIA	
MATERIAL: MOLDED GLASS EPOXY				CHK		NAME FLANGED RECEPTACLE ASSEMBLY LGN-1L	
FINISH: BLACK				APPD RE Fm 3-27-73		SIZE B	
NEXT ASSY				DSGN APPD		CODE IDENT NO. 00779	
FINAL ASSY				OTHER APPD		NUMBER 861255	
NEXT ASSY				USED ON		SCALE	
QTY REQD				APPLICATION		SHEET	

PRINT DIST 37