

# Solder Instruction

1. Cable should be prepared for soldering. The cable/wires must be pretinned.
2. Insert cable/wire into solder cup.
3. Signal Contact
  - 3.1. Operate the soldering iron at 350°C, 50 Watt max. and use a pencil tip.
  - 3.2. Put tip to wire in solder cup.
  - 3.3. After 1 second bring in solder.
  - 3.4. Heat for 3 seconds longer. Do not heat contact more than 4 seconds in total.
4. Power Contact
  - 4.1. Operate the soldering iron at 350°C, 100 Watt max. and use a pencil tip.
  - 4.2. Apply some solder to the solder tip of the soldering iron.
  - 4.3. Put tip to wire in solder cup.
  - 4.4. After 1 second bring in solder.
  - 4.5. Heat for 5 seconds longer. Do not heat contact more than 6 seconds in total.
5. Remove soldering iron.
6. Wait until solder gets rigid again.
7. Do not solder adjacent contacts consecutively, alternate position within the connector to minimize heat build up.

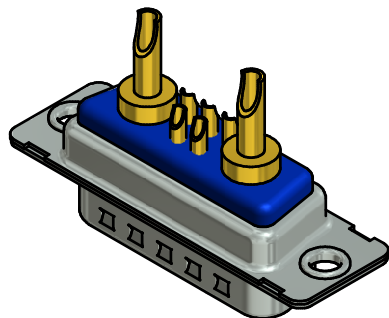

Directive 2002/95/EC RoHS compliant

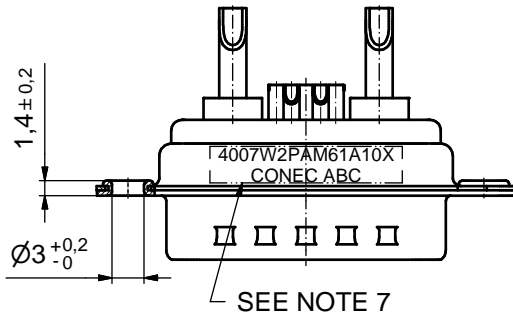
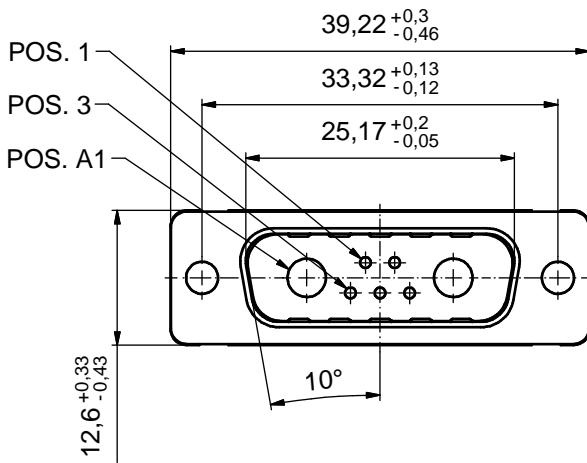
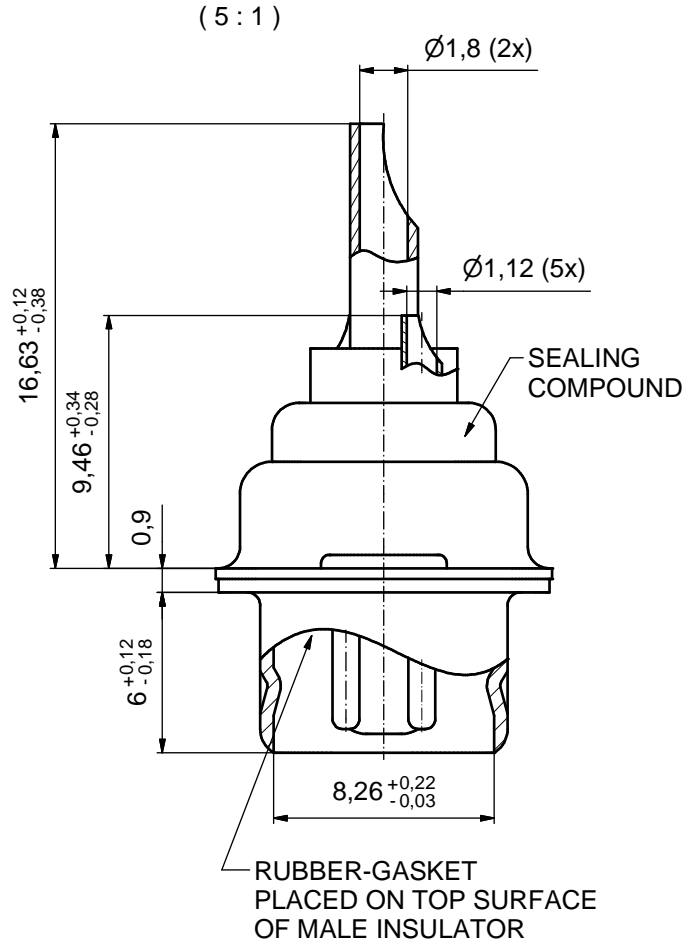

## NOTES:

1. METAL SHELLS: COPPER ALLOY; min. 315µm TIN over 40-80µm NICKEL
2. INSULATORS: PBT GF UL 94 V-0; GREEN
3. SIGNAL CONTACTS: COPPER ALLOY; PLATING: GOLD FLASH over NICKEL  
SOLDER CUP ACCEPTS CABLE AWG 20
4. HIGH POWER CONTACTS 10A: COPPER ALLOY;  
PLATING, MATING SIDE: GOLD FLASH over NICKEL  
PLATING, TERMINATION SIDE: GOLD FLASH over NICKEL  
SOLDER CUP ACCEPTS CABLE AWG 16-20
5. RUBBER GASKET: TPE; BLACK
6. SEALING COMPOUND: PUR; BLUE
7. CONNECTOR IS PART MARKED: 4007W2PAM61A10X CONEC ABC

THIS DRAWING MAY NOT BE COPIED OR REPRODUCED IN ANY WAY, AND MAY NOT BE PASSED ON TO A THIRD PARTY WITHOUT WRITTEN PERMISSION. OWNERSHIP AND COPYRIGHT OF CONEC GmbH DO NOT ALTER CAD DRAWING BY HAND	tolerance		dim. in mm		scale:	2:1 (5:1)
					material:	SEE NOTES
	date	name	title:			
	drawn	24.02.14	Schmidt	D-SUB COMBINATION MALE		
appd.	24.02.14	Lehmenkühler	7W2P SOLDER CUP			
norm			for installation into water resistant hood			
d-old			dwg no:			DIN-A3
a	Original		15K1A1452			sh: 1
rev.	description	date	name	part no: 4007W2PAM61A10X		

