

THIS DRAWING IS UNPUBLISHED. RELEASED FOR PUBLICATION  
 © COPYRIGHT - By - ALL RIGHTS RESERVED.

LOC		DIST		REVISIONS			
P	LTR	DESCRIPTION	DATE	DWN	APVD		
	A	PRODUCTION RELEASE PER ECO-13-014747	4 SEP 13	MKS	MKS		

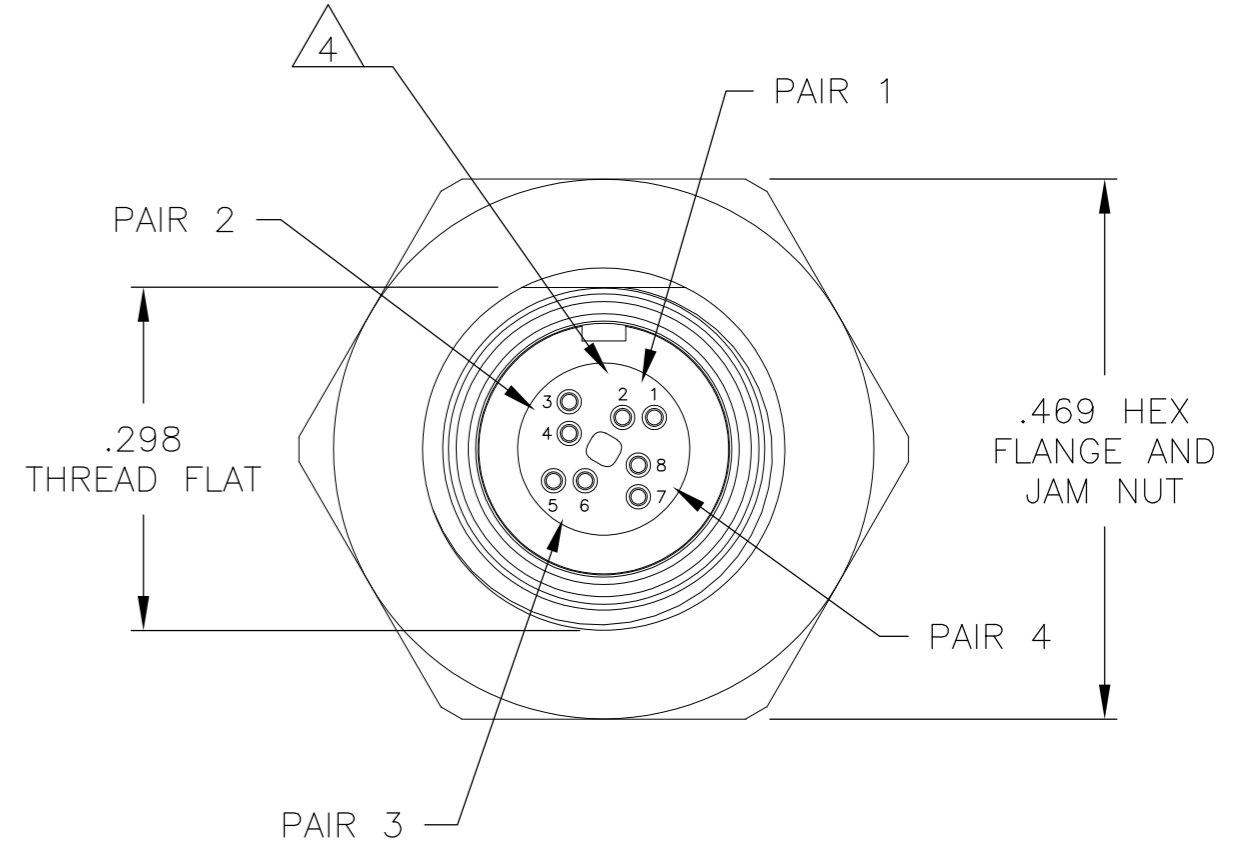
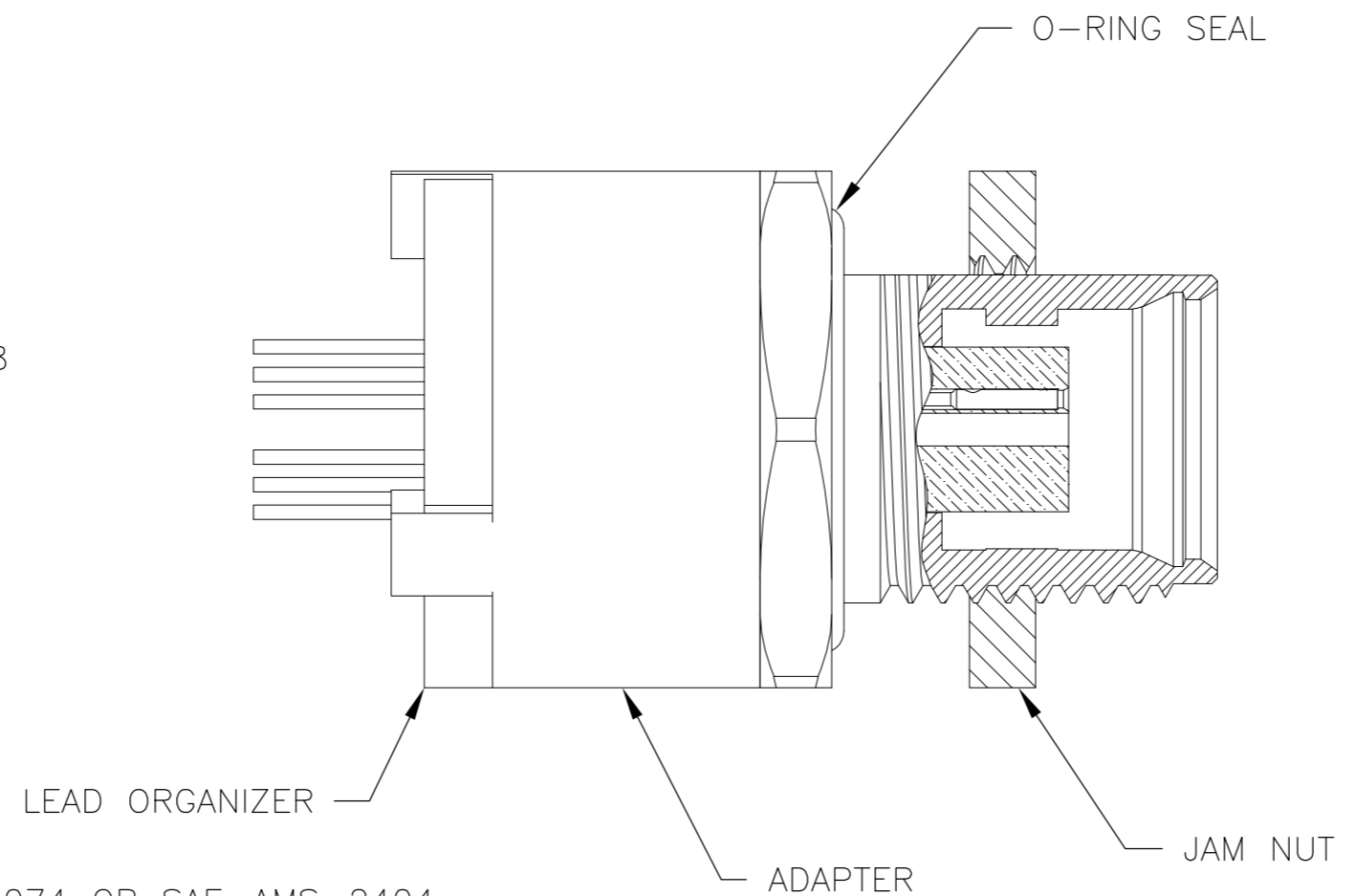
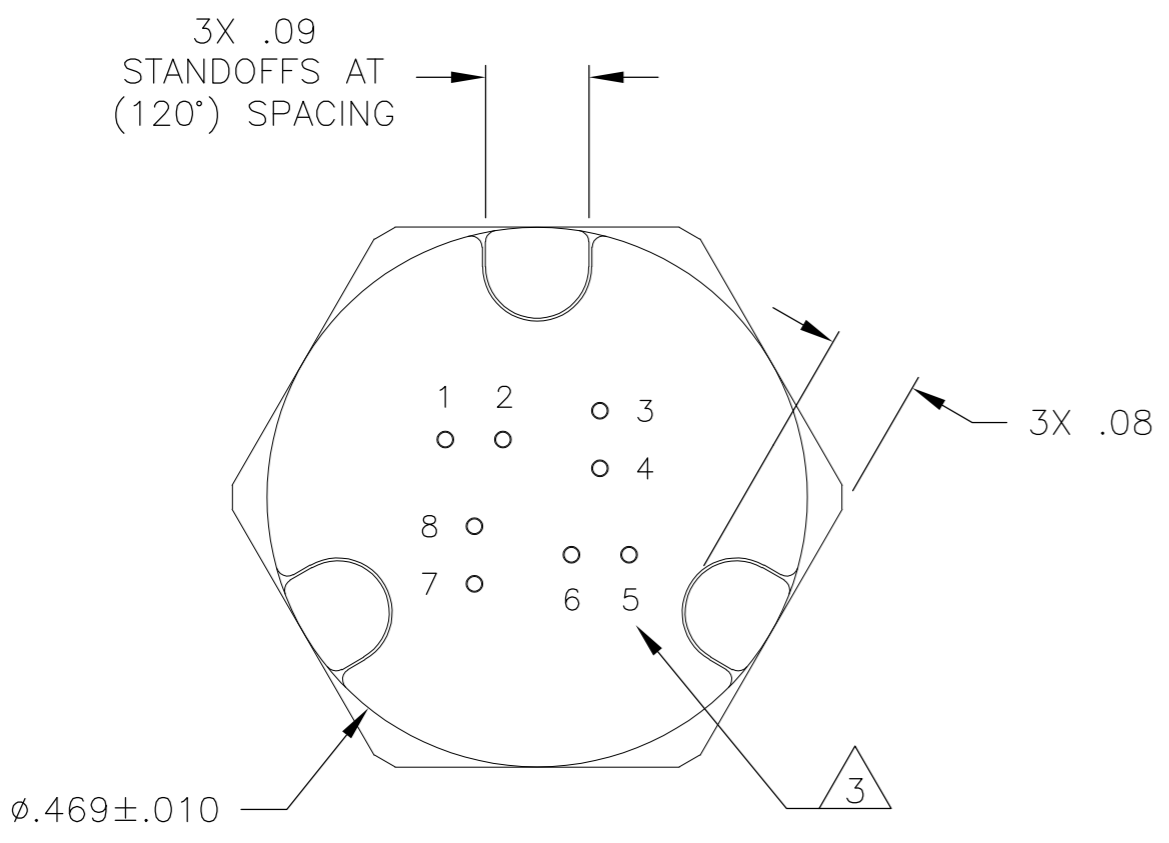
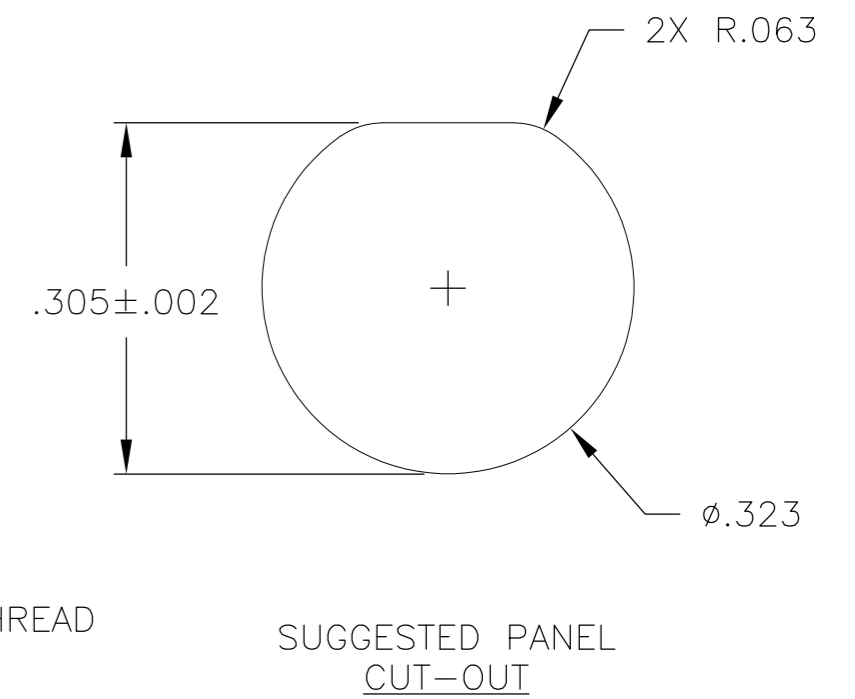
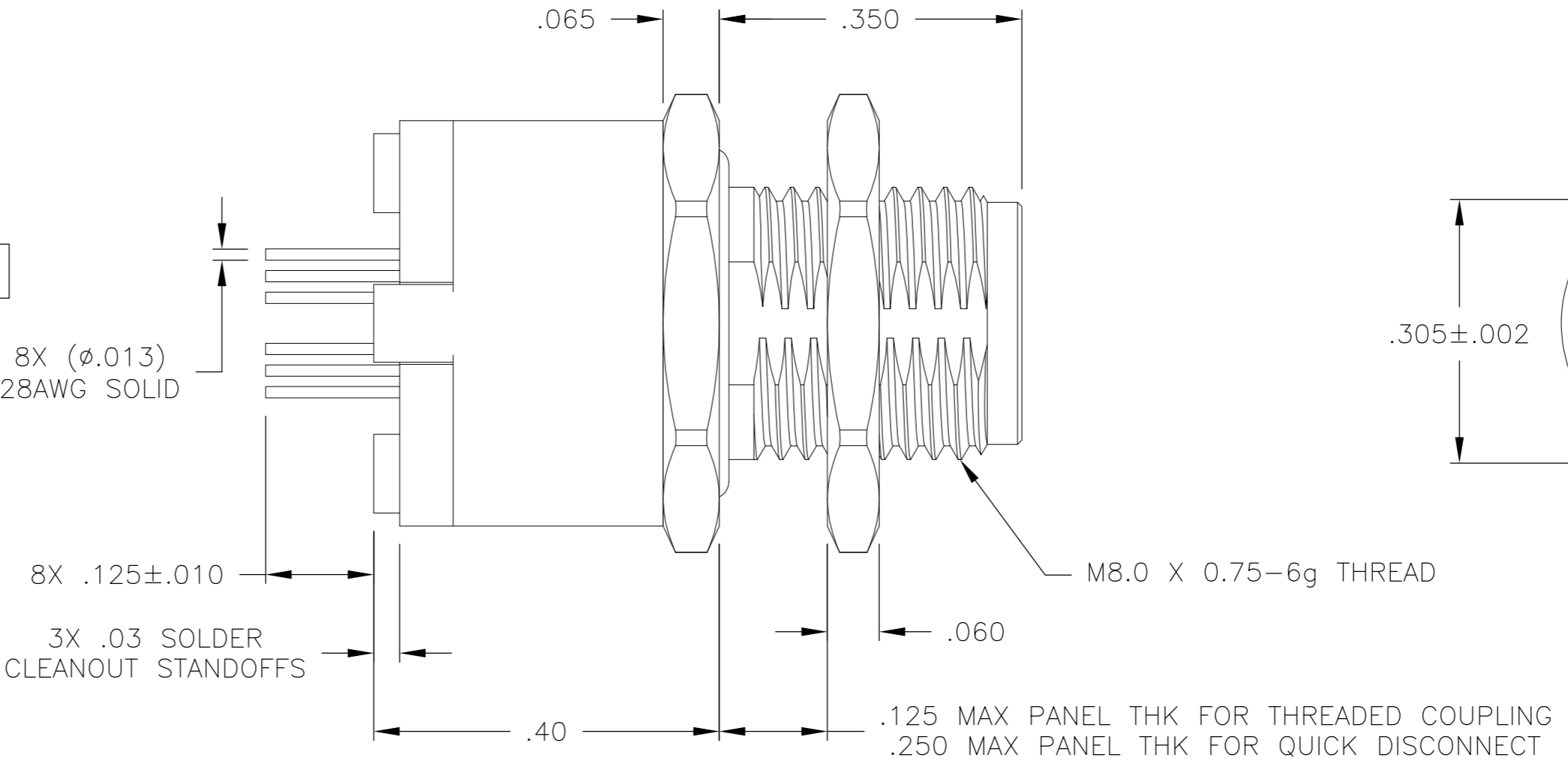
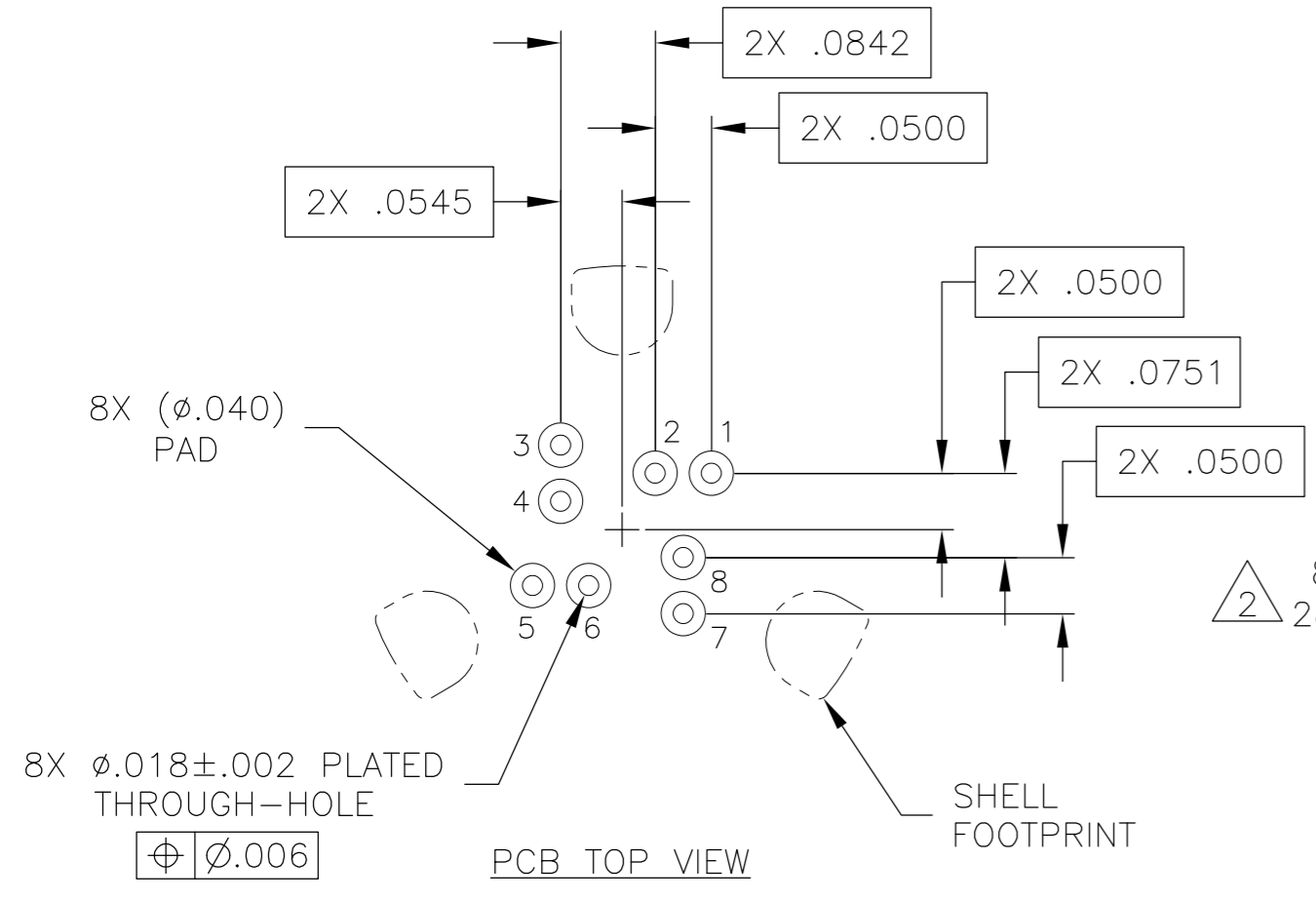

- 1 CONNECTOR BODY AND JAM NUT MATERIAL: 6061-T6 ALUMINUM, ELECTROLESS NICKEL PLATED PER SAE-AMS-C-26074 OR SAE-AMS-2404  
 INSULATOR MATERIAL: LIQUID CRYSTAL POLYMER (LCP) PER ASTM D5138  
 LEAD ORGANIZER AND ADAPTER MATERIAL: MACHINED OR MOLDED THERMOPLASTIC  
 O-RING MATERIAL: FLUOROSILICONE PER SAE-AMS-R-25988
- 2 TERMINATED WITH SOLID, UNINSULATED COPPER WIRE PER A-A-59551, Sn63Pb37 SOLDER DIPPED AT LEAD ENDS
- 3 LEAD POSITIONS ARE SHOWN FOR REFERENCE ONLY AND ARE NOT MARKED ON THE PART
- 4 CAVITY POSITIONS ARE SHOWN FOR REFERENCE ONLY AND ARE NOT MARKED ON THE PART
- 5 CONNECTORS SHALL BE 100% LEAK TESTED BY MOUNTING IN A SUITABLE PRESSURE TEST FIXTURE THAT SHALL BE PRESSURIZED WITH AIR TO 3.7PSI MINIMUM. AFTER PRESSURE STABILIZATION, THERE SHALL BE NO PRESSURE DROP OF MORE THAN 0.03PSI PERMISSIBLE OVER A PERIOD OF 2 MINUTES.
- 6 LUBRICATE O-RING WITH PARKER SUPER-O-LUBE PRIOR TO INSTALLATION
- 7 REFERENCE TE PRODUCT SPECIFICATION 108-32048 FOR PRODUCT DETAILS AND PERFORMANCE

THIS DRAWING IS A CONTROLLED DOCUMENT.		DWN	M STORRY	30 JUL 2012		TE Connectivity				
DIMENSIONS: INCHES		CHK	M STORRY	30 JUL 2012		NAME				
TOLERANCES UNLESS OTHERWISE SPECIFIED:		APVD	M STORRY	30 JUL 2012		RECEPTACLE ASSEMBLY, CIRCULAR, REAR PANEL MT, THD COUPLING/QUICK DISC, VERT MOUNT THRU-HOLE, METAL, 8 POS, 10GbE, CeeLok FAS-T Nano Circular				
0 PLC ± - 1 PLC ± - 2 PLC ± .010 3 PLC ± .005 4 PLC ± - ANGLES ± 1°		PRODUCT SPEC	APPLICATION SPEC			SIZE	CAGE CODE	DRAWING NO	RESTRICTED TO	
MATERIAL SEE NOTES		FINISH SEE NOTES		WEIGHT	A2 0PJN9 C=1925261		SCALE 6:1		SHEET 1 of 1	REV A