

- 1 ZINC PER QQ-Z-363.
- 2 POLYMETHYLPENTENE, GENERAL PURPOSE.
- 3 PHOSPHOR BRONZE PER QQ-B-750.
- 4 BRASS PER ASTM-B-453.
- 5 BRASS PER ASTM-B-16.
- 6 NICKEL PLATE PER QQ-N-290, 3.81 μm [.000150] MINIMUM THICK.
- 7 TIN PLATE PER ASTM-B-545, 3.81 μm [.000150] MINIMUM THICK.
- 8 GOLD PLATE PER MIL-G-45204, 0.76 μm [.000030] MINIMUM THICK.
- 9 PARTS PACKAGED UNASSEMBLED.

VIEW A

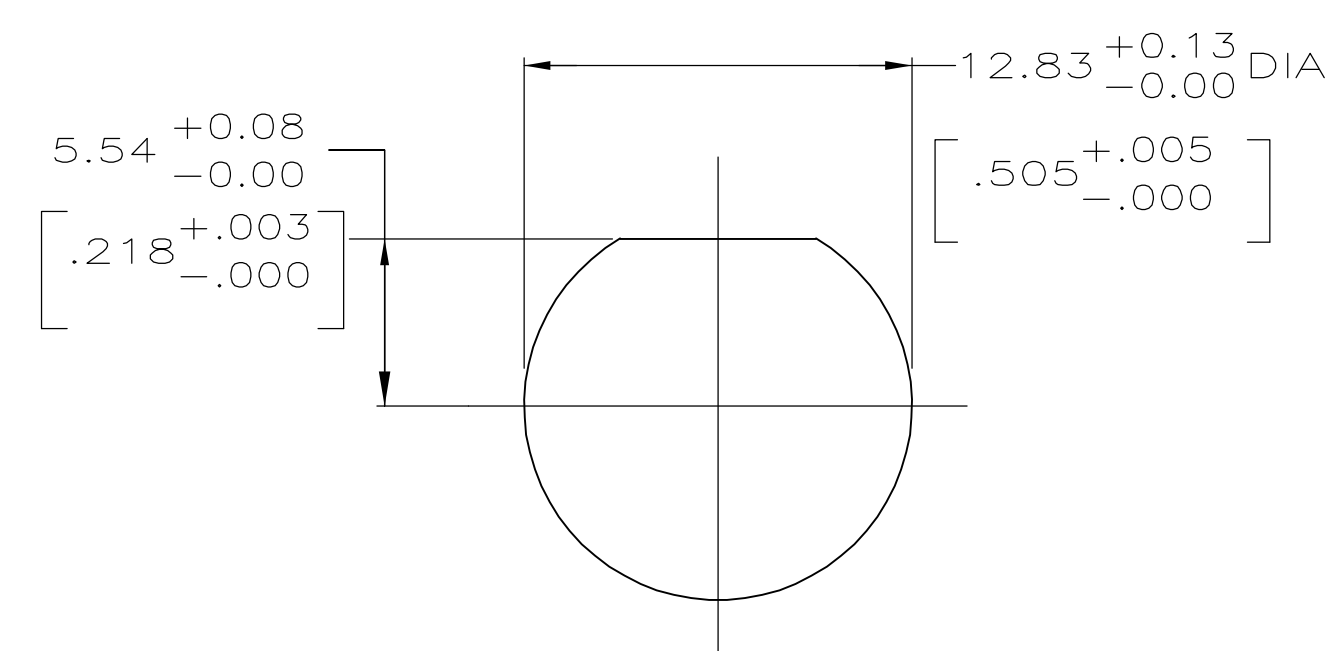

RECOMMENDED PANEL CUTOUT

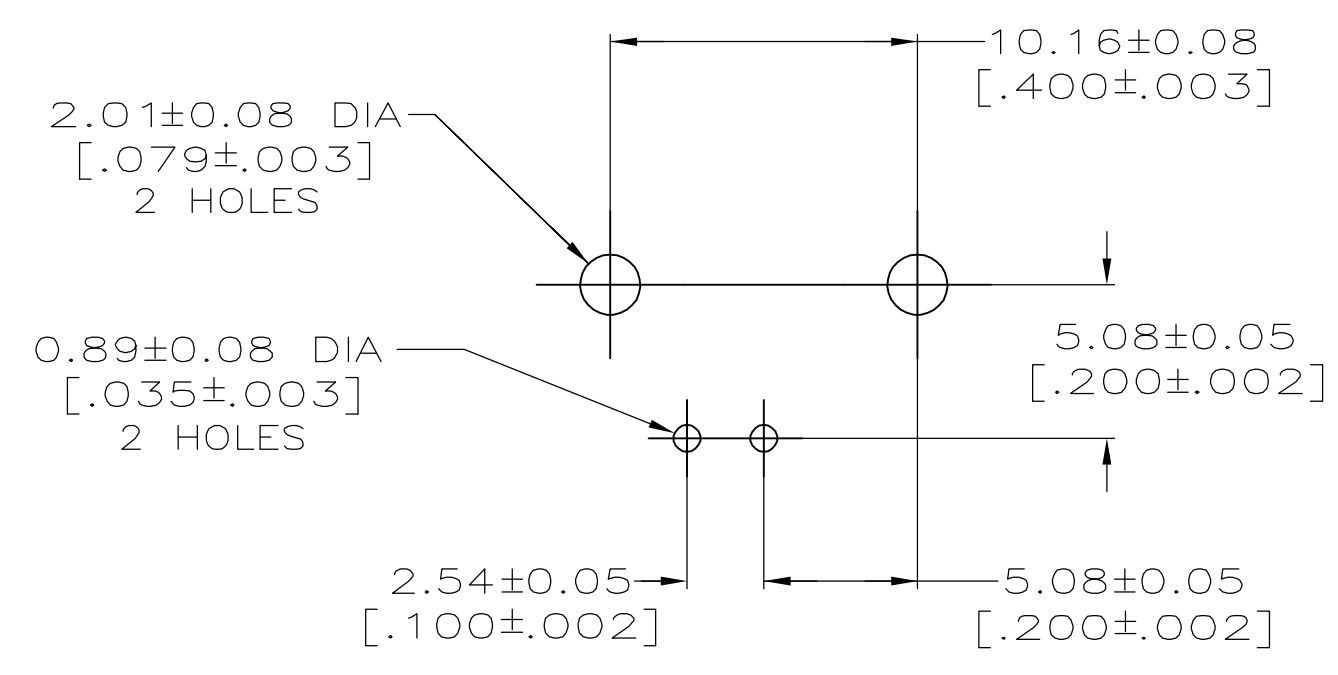

PCB CONFIGURATION

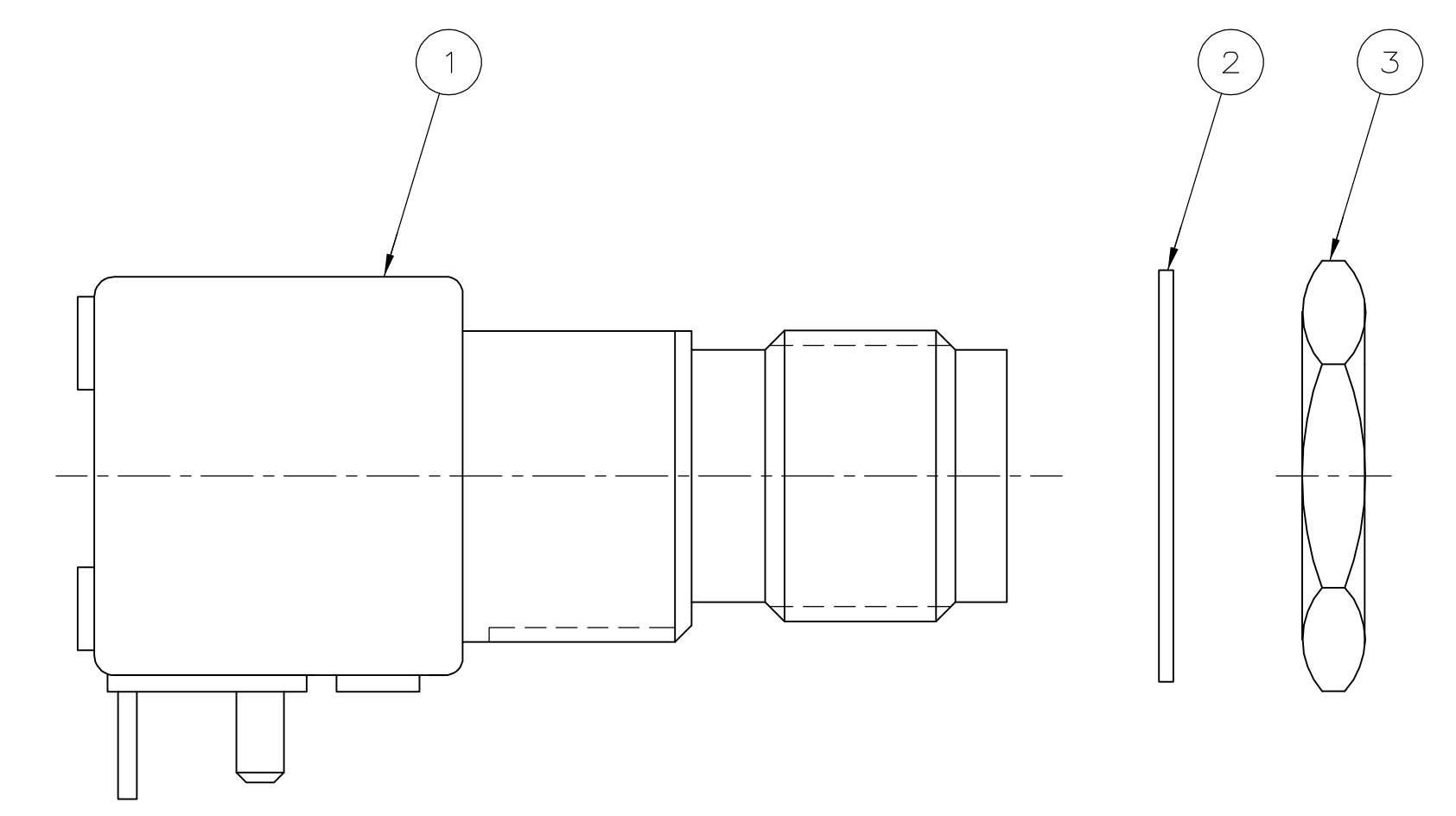

VIEW B

SUPERSEDED BY 227839-1	-	1-329632-2	1-329631-2	227839-1	B	227839-4
SUPERSEDED BY 227839-1	8	-	-	-	A	227839-3
CONTACT FINISH	3	LOCKWASHER QTY=1	2 JAM NUT QTY=1	1 JACK ASSY QTY=1	VIEW	PART NUMBER

THIS DRAWING IS A CONTROLLED DOCUMENT.		DIN J. LIPPERT 10-30-91	Tyco Electronics Corporation Harrisburg, PA 17105-3608
DIMENSIONS: INCHES		CHK A. GABANY 10-31-91	
TOLERANCES UNLESS OTHERWISE SPECIFIED:		APVD A. GABANY 10-31-91	NAME
0 PLC ± -	1 PLC ± -	PRODUCT SPEC	JACK, RIGHT ANGLE, 50 OHM, PCB, TNC
2 PLC ± 0.20 [.008]	3 PLC ± -	APPLICATION SPEC	
4 PLC ± -	ANGLES ± -	SIZE	CAGE CODE DRAWING NO
MATERIAL SEE NOTES 1-4	FINISH SEE NOTES 5-7	WEIGHT	RESTRICTED TO
CUSTOMER DRAWING		SCALE 4:1	SHEET 1 OF 1 REV F