

PART NUMBER	REV	FIRST USED
680037-1	C	854400-1
680037-2	C	565435-5

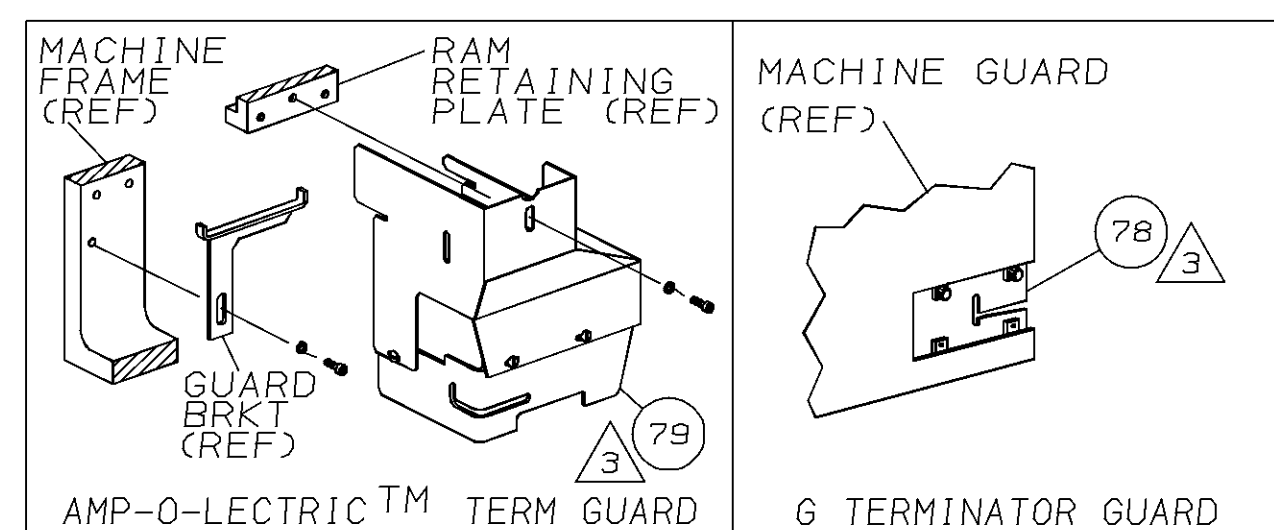

TERMINAL NAME: 2.5mm FLAG CONTACT, SOCKET						
CRIMPING DATA						
PAD LTR	CRIMP HEIGHT		WIRE SIZE			
A	.056 ± .002 [1.42 ± 0.05mm]		1mm <sup>2</sup>			
B	.052 ± .002 [1.32 ± 0.05mm]		0.75mm <sup>2</sup>			
C	.048 ± .002 [1.22 ± 0.05mm]		0.5mm <sup>2</sup>			
D	NOT		USED			
CRIMP	SIZE	TYPE	RANGE			
WIRE	.080 [2.03mm]	F	0.5 - 1mm <sup>2</sup>			
INSUL	.110 [2.79mm]	F	1.4 - 2.3mm			
WIRE STRIP LENGTH	TERM APPL	SPEC	FEED	APPL INSTRUCTION	SET UP GAGE	LAYOUT
-	-	-	.788	408-8039	458638-1	L1527

QTY	REV	U/M	DWG SIZE	PART NO	DESCRIPTION	ITEM NO
1	-	-	-	692655-5	AIR FEED VALVE ASSY	70
1	-	-	-	24042-2	VALVE, SHUT OFF	69
1	-	-	-	692655-6	AIR FEED VALVE ASSY	68
1	-	-	-	460277-1	AIR FEED ASSY	67
2	2	-	-	3-21000-9	SCR,SHC 10-32x1.00 AIR ASSY	66
-	1	-	-	22294-6	ELBOW, TUBING 1/8NPT - 1/4 T	65
-	1	-	-	23238-1	QUICK DISCONNECT	64
12.00	12.00	IN	-	27319-4	TUBING, POLY-FLO Ø.25	63
1	1	-	-	467284-1	CAP, RAM	62
1	1	-	-	683742-1	HOUSING	61
1	1	-	-	679904-1	PAWL, FEED	60
1	1	-	-	461062-1	HOLDER, FEED FINGER	59
1	1	-	-	690191-1	PLUG, NYLON	58
1	1	-	-	683741-2	RAM	57
1	1	-	-	690125-1	WASHER, LAMINATED	56
1	1	-	-	690124-9	WASHER, RAM	55
1	1	-	-	7-21002-9	BOLT, CRIMPER(5/16-24x1.00)	54
1	1	-	-	23241-6	BALL, STEEL	53
1	1	-	-	690170-1	SPRING, COMPRESSION	52
1	1	-	-	690142-1	DISC, INSULATION	51
1	1	-	-	354777-1	WIRE DISC, PLASTIC	50
1	1	-	-	22480-5	WASHER, SPRING	49
1	1	-	-	690212-1	POST, RAM	48
1	1	-	-	240793-1	LEVER, DRAG RELEASE	47
1	1	-	-	3-690451-2	SPACER, STRIPPER	46
1	1	-	-	240639-1	STRIPPER	45
1	1	-	-	679850-1	PLATE, BASE	44
1	1	-	-	240792-1	DRAG, TERMINAL	43
1	1	-	-	679868-1	PLATE, STRIP GUIDE	42
2	2	-	-	1-22284-0	SPRING, DRAG	41
1	1	-	-	679768-1	GUIDE, STRIP (REAR)	40
1	1	-	-	690438-2	GUIDE, STRIP (FRONT)	39
1	1	-	-	5-22280-0	SPRING, SHEAR	38
1	1	-	-	1-609461-3	STOP, SHEAR	37
1	1	-	-	679829-1	HOLDER, SHEAR	36
1	1	-	-	679835-1	SHEAR, FLOATING	35
1	1	-	-	679887-1	ANVIL	34
1	1	-	-	467499-3	HOLD DOWN, TERMINAL	33
1	1	-	-	1-238009-2	SPACER, BLOCK CRIMPER	32
1	1	-	-	5-683453-0	CRIMPER, INSULATION	31
1	1	-	-	1-455888-6	SPACER, CRIMPER	30
1	1	-	-	2-456405-7	CRIMPER, WIRE	29

QTY	REV	U/M	DWG SIZE	PART NO	DESCRIPTION	ITEM NO
2	2	-	-	2-354779-4	PIN, WIRE DISC (.3110)C	129
2	2	-	-	1-354779-6	PIN, WIRE DISC (.3070)B	128
2	2	-	-	354779-7	PIN, WIRE DISC (.3025)A	127
1	1	-	-	986950-1	WASHER, FLAT PRECISION	126
						125
						124
						123
						122
						121
						120
						119
						118
						117
						116
						115
2	2	-	-	21024-2	WASHER, LOCK (NO.4) ST GU PL	114
2	2	-	-	21024-5	WASHER, LOCK (NO.10) SHEAR PL	113
						112
						111
1	1	-	-	21024-4	WASHER, LOCK (NO.8) FEED	110
2	2	-	-	21024-3	WASHER, LOCK (NO.6) ST GU PL	109
						108
						107
1	1	-	-	22353-8	SCR,SHLD(Ø.187x.25)DRAG LEVER	106
						105
						104
1	1	-	-	2-21000-6	SCR,SHC(8-32x.38)FEED HOLDER	103
2	2	-	-	2-21006-6	SCR,SKT SET(4-40x.62)DRAG	102
1	1	-	-	21009-2	SCR,SKT SET(1/4-20x.25)RAM	101
2	2	-	-	21017-2	SCR,DRIVE(#2x.19)ID PLATE	100
2	2	-	-	3-21002-0	SCR,BHC(10-32x.88)DRAG	99
1	1	-	-	461264-1	PLATE, IDENTIFICATION	98
						97
						96
2	2	-	-	2-21002-2	SCR,BHC(8-32x.50)STRIPPER	95
4	4	-	-	2-21002-9	SCR,BHC(10-32x.75)CAP	94
1	1	-	-	22733-8	SCR,BHC(8-32x.38 LW)ANVIL	93
4	4	-	-	3-21002-3	SCR,BHC(1/4-20x.50)ST GD PL	92
3	3	-	-	2-22733-8	SCR,BHC(1/4-20x.62)HSG	91
						90
						89
						88
1	1	-	-	3-21000-7	SCR,SHC(8-32x.50)SHEAR DEP	87
2	2	-	-	2-21000-0	SCR,SHC(8-32x.50)STRIP GUIDE	86
2	2	-	-	1-21000-3	SCR,SHC(4-40x.25)F ST GU	85
						84
						83
						82
						81
2	2	-	-	3-21000-8	SCR,SKT CAP(10-32x.88)SH PL	80
1	-	-	-	455750-7	GUARD ASSY	79
-	-	REF	-	679532-1	INSERT, GUARD	78
						77
						76
						75
1	1	-	-	690603-1	SPRING, ASSIST	74
1	1	-	-	23030-1	SCR,SKT CAP(6-32x.25)CP DSC	73
						72
						71

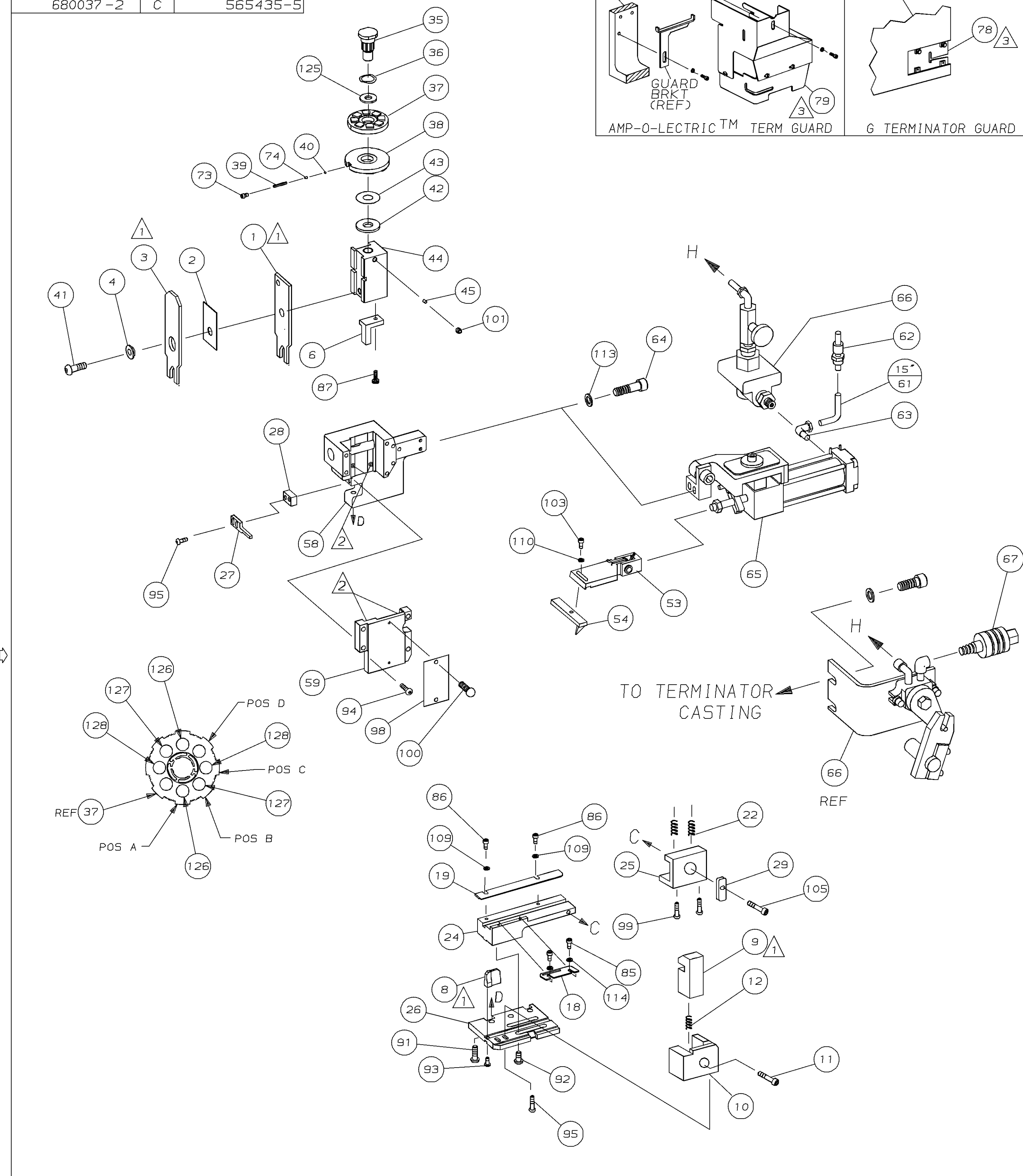

- 1 RECOMMENDED SPARE PARTS.
- 2 GREASE LIGHTLY.
- 3 GUARD MUST BE IN PLACE WHEN OPERATING APPLICATOR IN A BENCH MACHINE.
- 4 SEE DRAWING FOR COMPONENTS
- 5 ITEM 78 REQUIRED FOR BENCH G TERMINATOR ONLY.

LOC A  
DIST 66

THIS DRAWING IS A CONTROLLED DOCUMENT FOR AMP INCORPORATED. IT IS SUBJECT TO CHANGE AND THE CONTROLLING ENGINEERING ORGANIZATION SHOULD BE CONTACTED FOR THE LATEST REVISION.

THIS INFORMATION IS CONFIDENTIAL AND IS DISCLOSED TO YOU ON CONDITION THAT NO FURTHER DISCLOSURE IS MADE BY YOU TO OTHER THAN AMP PERSONNEL WITHOUT WRITTEN AUTHORIZATION FROM AMP INCORPORATED, HARRISBURG, PA.

680037

REVISION OF EACH ASSY NO (WHEN BLANK, USE DWG REVISION)		PARTS LIST	
QTY	REV	U/M	DWG SIZE
-2	-1	U/M	DWG SIZE

DIMENSIONS IN INCHES. DO NOT SCALE PRINT. TOLERANCES UNLESS OTHERWISE SPECIFIED.		MATERIAL		FINISH	
DR	11/5/93	APP	11/8/93	HT TR	-
P. MATHIAS		B. WOLFE		FIN	-
CHK	11/8/93	REL	11/19/93		
3 PLC DEC ± .25		C. ERISMAN	G. OCHENIS		
4 PLC DEC ± .					

NAME	END FEED HDM APPLICATOR	MACHINE REF	MINI APPL
SCALE	DWG NO	680037	SHEET REV
			1 OF 1 C