

LOC		DIST		ZONE		LTR		REVISIONS		DATE	APPD
AF	50	P	F			F		REVISED PER 0710-0453-95	20/OCT/95	MF/NN	

- 1 CONTINUOUS STRIP ON REELS WITH TERMINALS LOCATED ON 5.59±0.08 [.220±.003] CENTERS.
- 2 SLOT ACCEPTS A SINGLE WIRE MAX OF 0.18-0.23mm [#33-#31] AWG COPPER MAGNET WIRE.
- 3 POKE-IN ACCEPTS A 0.5-0.8mm² [#20-#18] AWG SOLID OR FUSED STRANDED LEAD WIRE.
- 4 AFTER INSERTION INTO PLASTIC HOLDER TAB PORTION MUST BE BENT OVER 45° TO 90° OR POTTED-IN TO PREVENT PULL-OUT WHEN MATING RECEPTACLE IS DISCONNECTED.

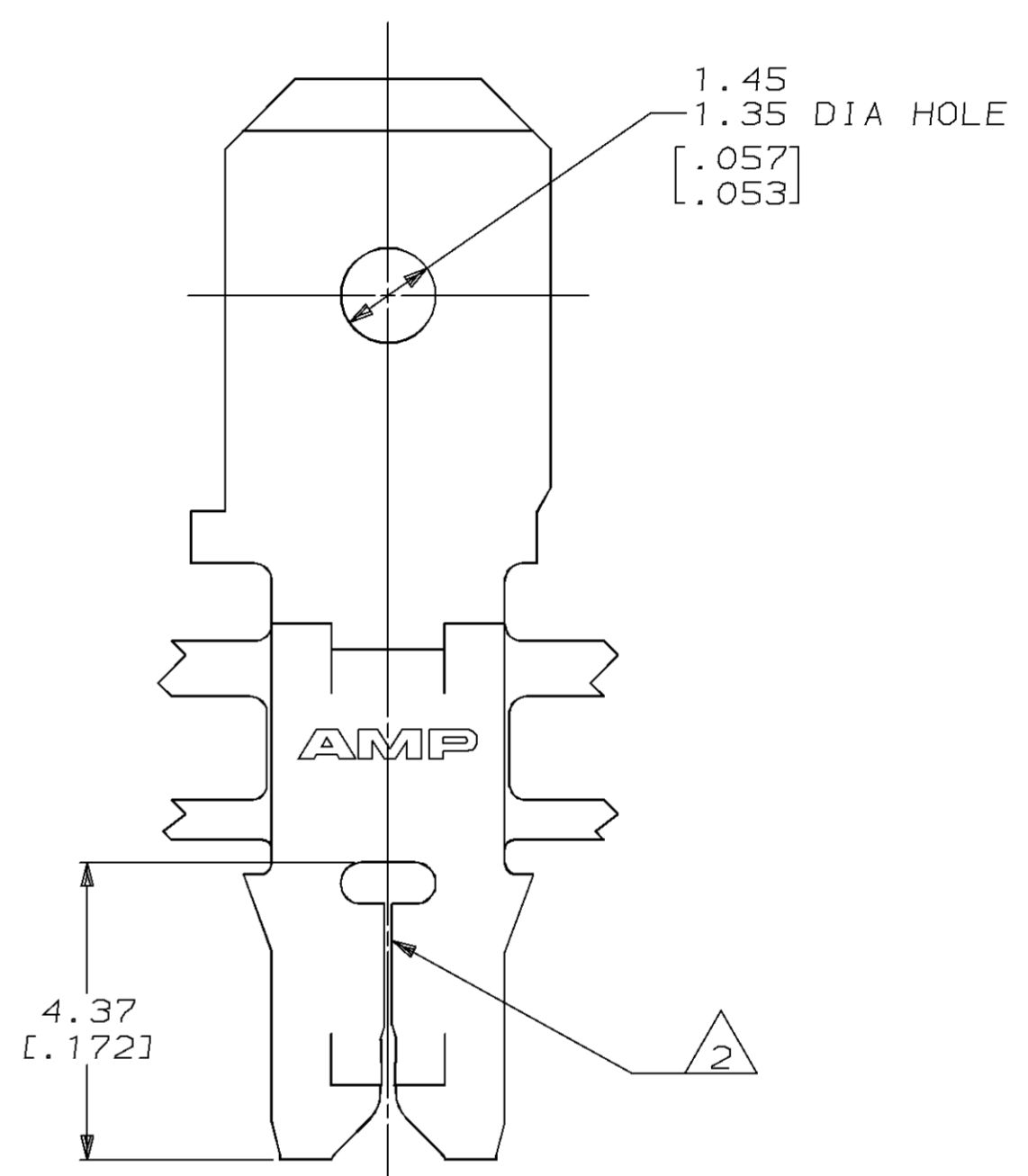
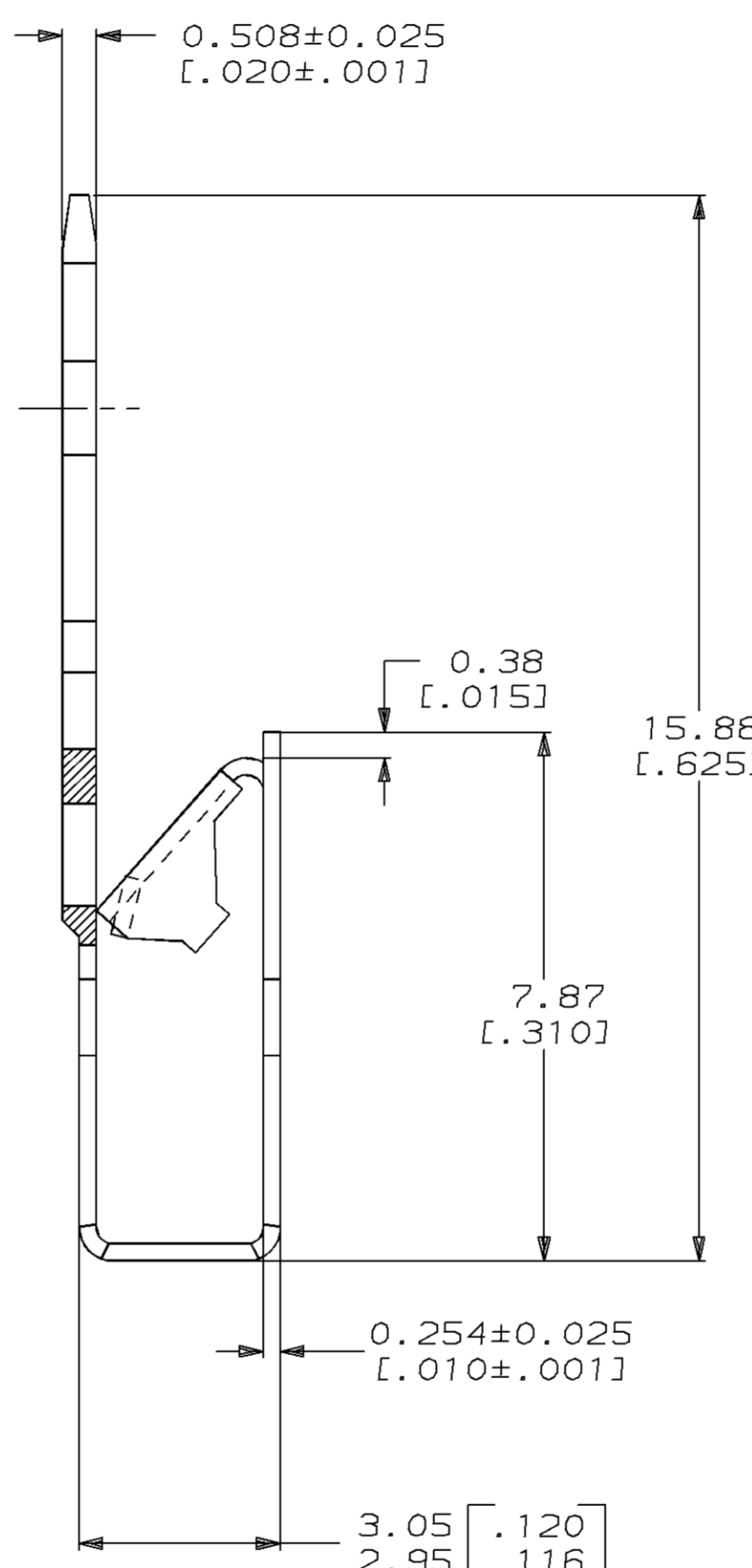
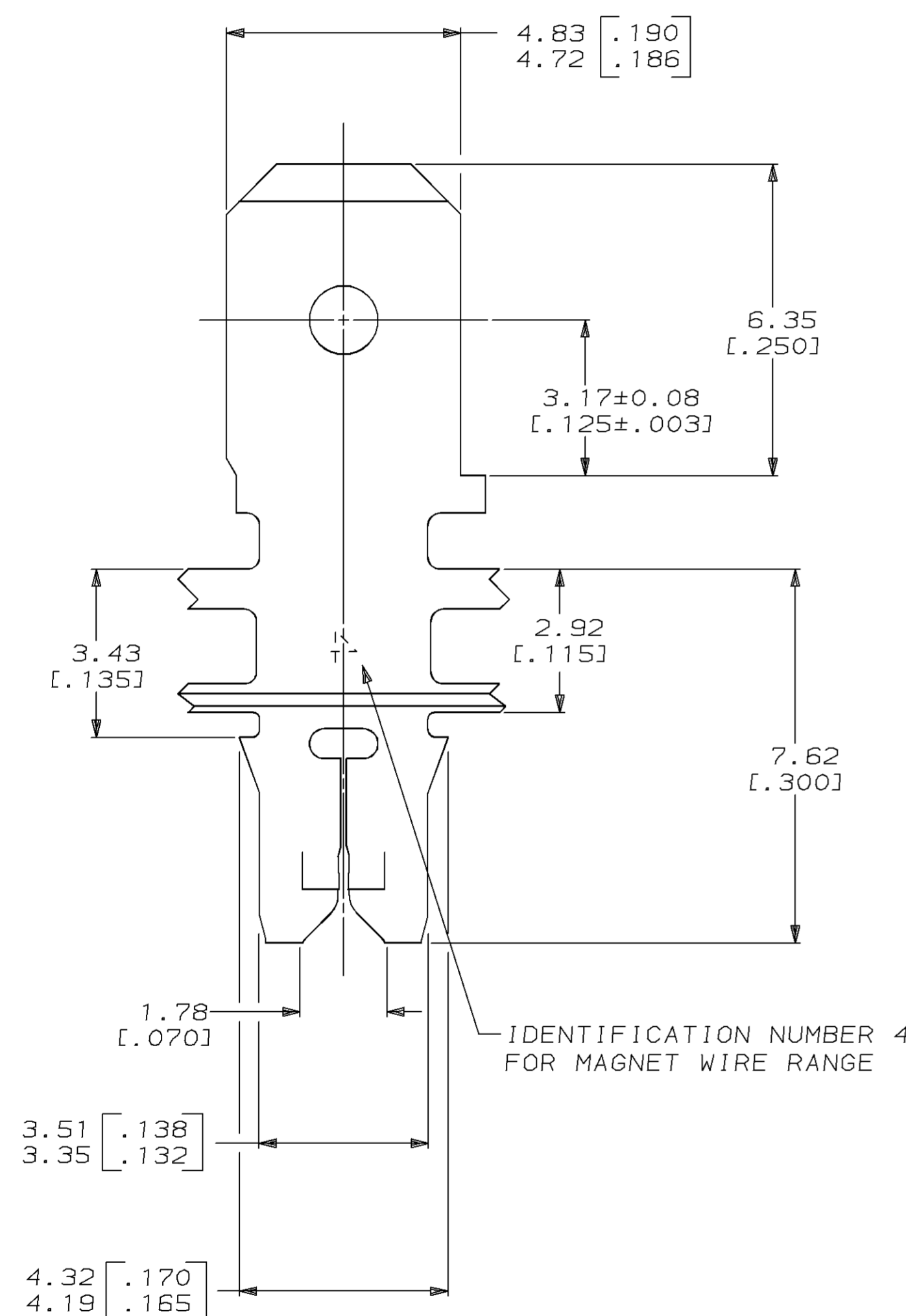
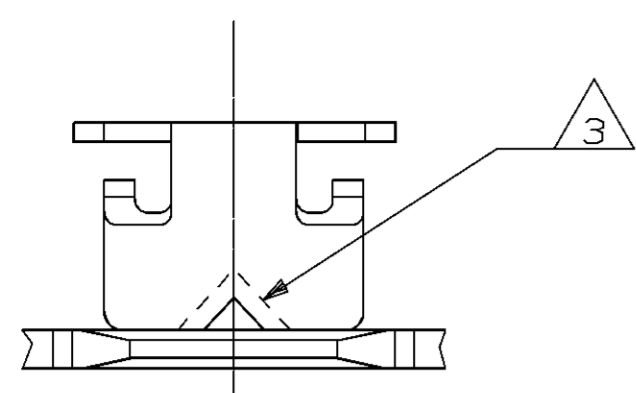

DO NOT SCALE PRINT. UNLESS SPECIFIED DIMENSIONS IN mm [INCHES] TOLERANCES ON: 2 PLC DEC ± 0.25 [.010] 3 PLC DEC ± - ANGLES ± -		DR 4-12-94 RAYMOND R. BUCHHEISTER JR. CHK 4-22-94 MICHAEL S. FEHER APPD 4-27-94 NELSON E. NEFF APPD 4-27-94 TERRY L. SHUTTER		AMP Incorporated Harrisburg, PA 17105-3608	
MATERIAL 4M PRE-MILLED BRASS		PRODUCT SPEC 108-2012		NAME TERMINAL, TAB, POKE-IN/4.75 [.187] FASTON™ COMBINATION, MAG-MATE™	
FINISH 0.002032 [.000080] MIN TIN PER MIL-T-10727		APPLICATION SPEC 114-2046		SIZE C	CAGE CODE 00779
THIS DRAWING IS A CONTROLLED DOCUMENT FOR AMP INCORPORATED. IT IS SUBJECT TO CHANGE AND THE CONTROLLING ENGINEERING ORGANIZATION SHOULD BE CONTACTED FOR THE LATEST REVISION.		WEIGHT -		DRAWING NO C=63018	SHEET 1 OF 1