

LOC		DIST		REVISIONS				DATE	APPD
ZONE	LTR	DESCRIPTION	DATE	APPD					
G	14	P	F	D	REVISED PER 0720-0230-93	2/25/94	OK	DAP	

METRIC
 DIMENSIONS LISTED IN mm [INCHES]

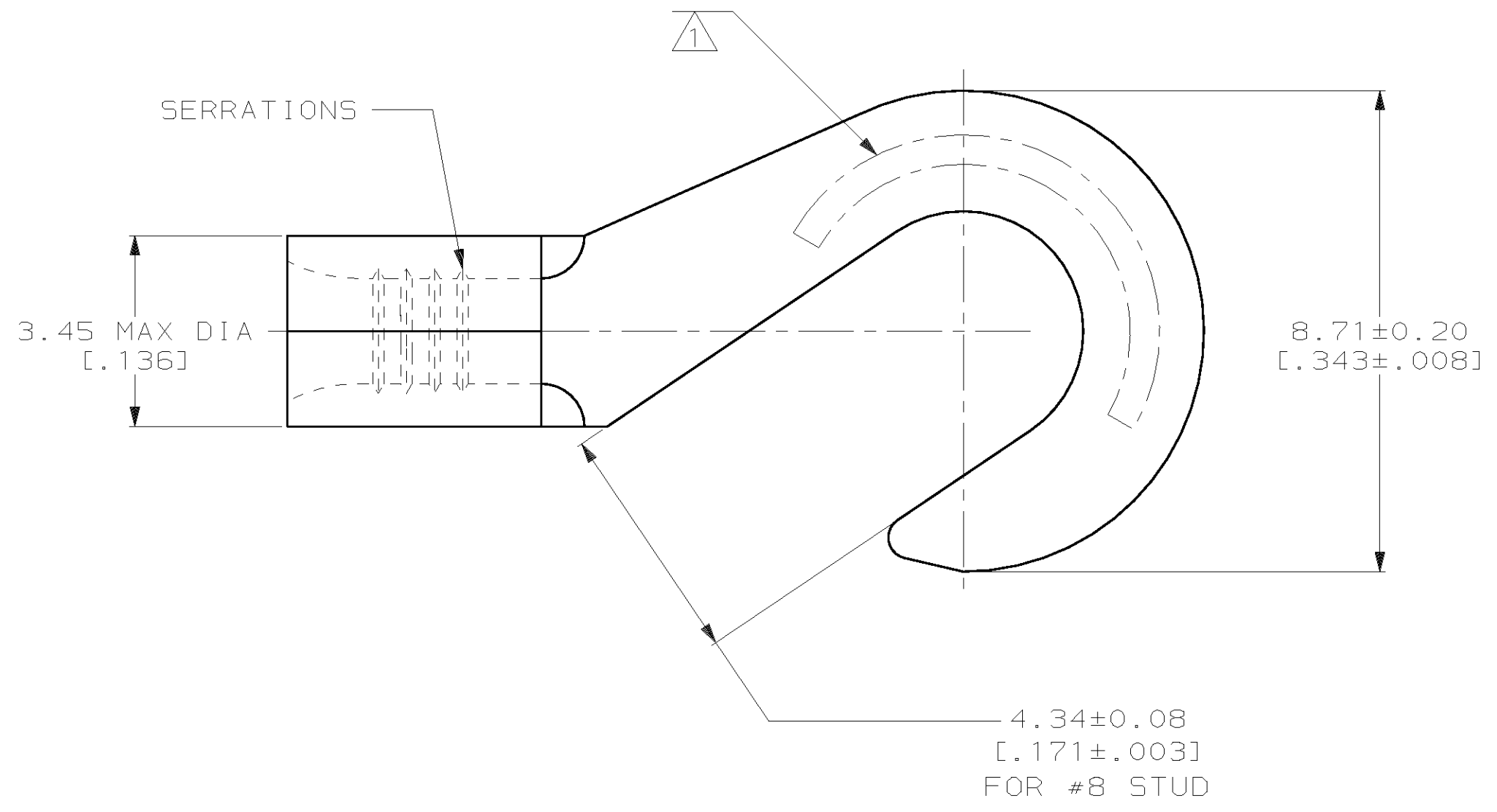

AMP WIRE RANGE	UL E13288 Listed
22-16 AWG STRANDED	22-16 AWG STRANDED
SP LR7189 Certified	MILITARY P/N AND CLASS
NOT CERTIFIED	NOT APPLICABLE

△ STAMP AMP 22-18* APPROX AS SHOWN
 22-16 TERMINALS ARE STAMPED 22-18 IN
 ACCORDANCE WITH MILITARY SPECIFICATION
 MIL-T-7928; COMMERCIAL WIRE RANGE IS 22-16

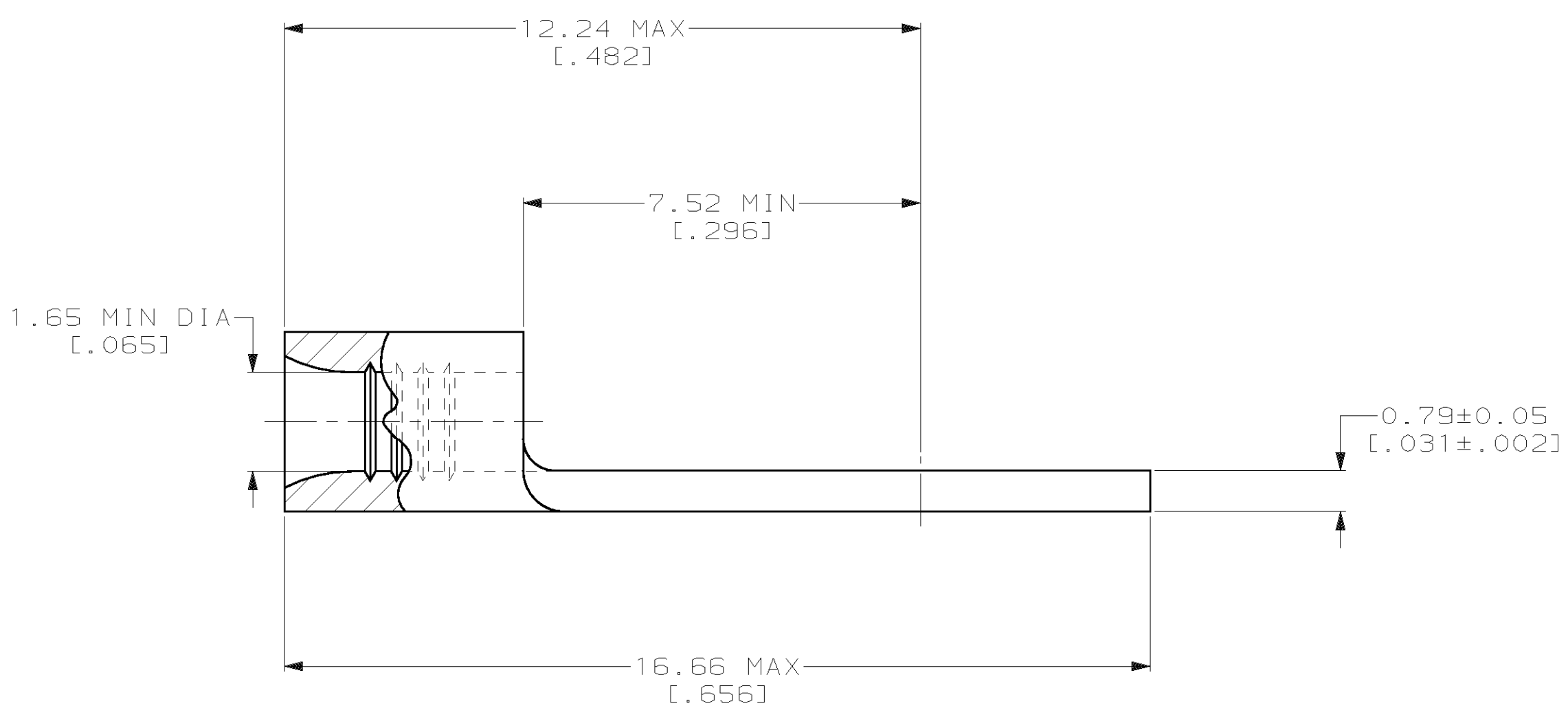

31628
 PART NO

AMP INCORPORATED
CUSTOMER SERVICE SYSTEMS

MAX RECOMMENDED OPERATING TEMPERATURE:
 170°C MAX

DO NOT SCALE PRINT.
 UNLESS SPECIFIED
 DIMENSIONS IN mm [INCHES]
 TOLERANCES ON :
 2 PLC DEC ± -
 3 PLC DEC ± -
 ANGLES ± -
 MATERIAL
 COPPER PER
 ASTM B-152
 ANNEALED
 FINISH
 TIN PLATE
 0.00254 [.000100] MIN
 THK PER MIL-T-10727

DR 2-25-93
 TA BRINKMAN
 CHK 2-25-93
 DA PATTERSON
 APPD 2-25-93
 DE MILLER
 APPD 2-25-93
 JL MECKLEY
 PRODUCT SPEC
 -
 APPLICATION SPEC
 -
 WEIGHT
 -

AMP AMP Incorporated
 Harrisburg, PA 17105-3608

NAME
**TERMINAL, HOOK TONGUE,
 BUDGET**

FOR ADDITIONAL PRODUCT INFORMATION OR COPIES OF DRAWINGS AND TECHNICAL DOCUMENTS
 PRODUCT INFORMATION CENTER
 1-800-522-6752

FOR APPLICATION TOOLING INFORMATION
 TOOLING ASSISTANCE CENTER
 1-800-722-1111

FOR ORDER ENTRY
 1-800-526-5142

VOLTAGE RATING:
 NOT APPLICABLE

WIRE CROSS SECTIONAL AREA RANGE:
 0.26-1.65mm² [509-3,260] CIR MILS
 STRANDED

THIS DRAWING IS A CONTROLLED DOCUMENT FOR AMP INCORPORATED. IT IS SUBJECT TO CHANGE AND THE CONTROLLING ENGINEERING ORGANIZATION SHOULD BE CONTACTED FOR THE LATEST REVISION.

SIZE CAGE CODE DRAWING NO
 C 00779 C-31628

SCALE 10:1 SHEET 1 OF 1