

**Product Description**

Peregrine’s PE3336 is a high performance integer-N PLL capable of frequency synthesis up to 3 GHz. The superior phase noise performance of the PE3336 makes it ideal for applications such as LMDS / MMDS / WLL basestations and demanding terrestrial systems.

The PE3336 features a 10/11 dual modulus prescaler, counters and a phase comparator as shown in *Figure 1*. Counter values are programmable through either a serial or parallel interface and can also be directly hard wired.

The PE3336 Phase Locked-Loop is optimized for terrestrial applications. It is manufactured on Peregrine’s UltraCMOS™ process, a patented variation of silicon-on-insulator (SOI) technology on a sapphire substrate, offering the performance of GaAs with the economy and integration of conventional CMOS.

**Features**

- 3 GHz operation
- ÷10/11 dual modulus prescaler
- Internal phase detector
- Serial, parallel or hardwired programmable
- Pin compatible with PE3236
- Ultra-low phase noise
- Available in a 7 x 7 mm 48-lead QFN green (RoHS-Compliant) package

**Figure 1. Block Diagram**

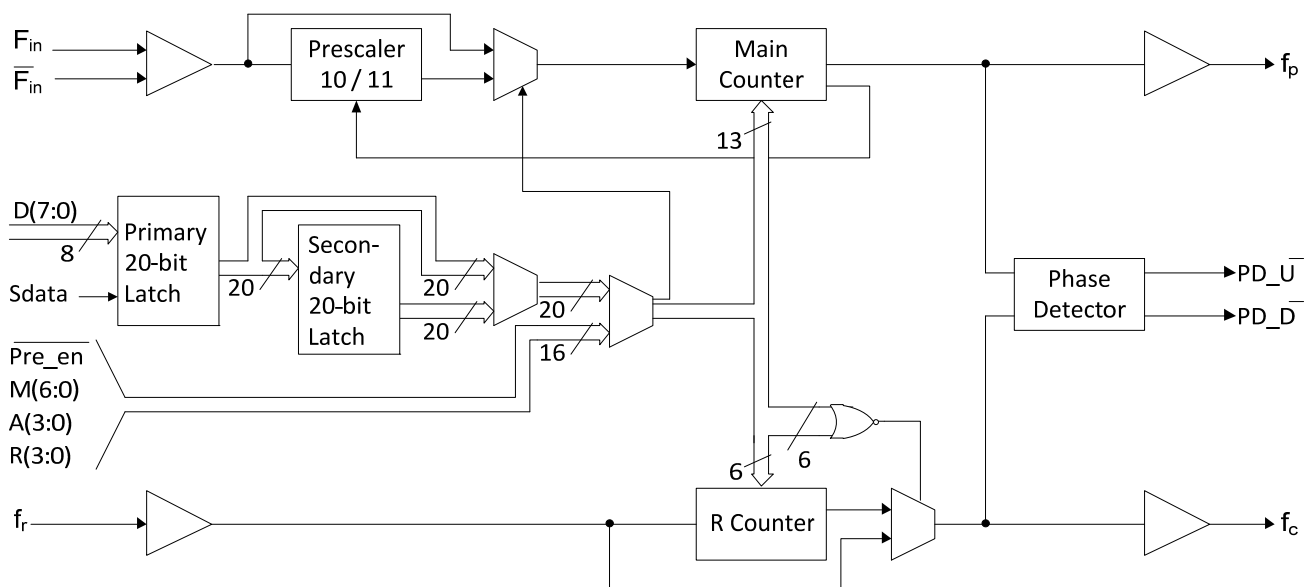

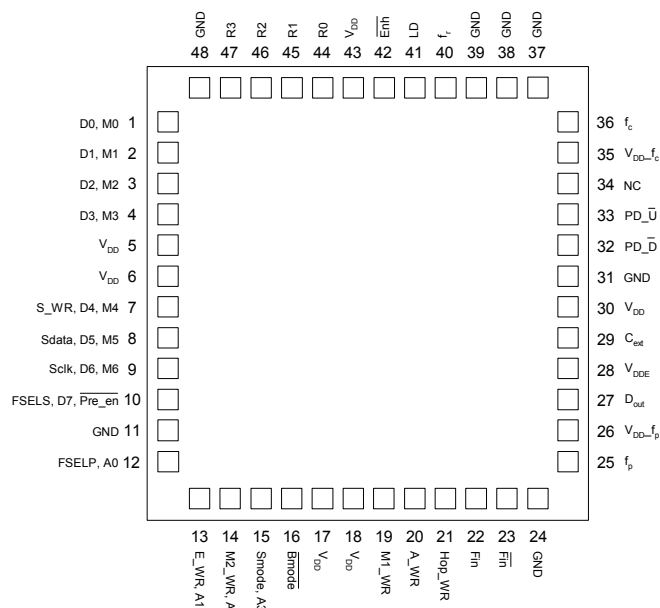
**Figure 2. Pin Configurations (Top View)**

48-lead QFN (RoHS-Compliant)

**Table 1. Pin Descriptions**

Pin No.	Pin Name	Interface Mode	Type	Description
1	D <sub>0</sub>	Parallel	Input	Parallel data bus bit0 (LSB).
	M <sub>0</sub>	Direct	Input	M Counter bit0 (LSB).
2	D <sub>1</sub>	Parallel	Input	Parallel data bus bit1.
	M <sub>1</sub>	Direct	Input	M Counter bit1.
3	D <sub>2</sub>	Parallel	Input	Parallel data bus bit2.
	M <sub>2</sub>	Direct	Input	M Counter bit2.
4	D <sub>3</sub>	Parallel	Input	Parallel data bus bit3.
	M <sub>3</sub>	Direct	Input	M Counter bit3.
5	V <sub>DD</sub>	ALL	(Note 1)	Power supply input. Input may range from 2.85 V to 3.15 V. Bypassing recommended.
6	V <sub>DD</sub>	ALL	(Note 1)	Power supply input. Input may range from 2.85 V to 3.15 V. Bypassing recommended.

**Table 1. Pin Descriptions (continued)**

Pin No.	Pin Name	Interface Mode	Type	Description
7	S_WR	Serial	Input	Serial load enable input. While S_WR is “low”, Sdata can be serially clocked. Primary register data are transferred to the secondary register on S_WR or Hop_WR rising edge.
	D <sub>4</sub>	Parallel	Input	Parallel data bus bit4
	M <sub>4</sub>	Direct	Input	M Counter bit4
8	Sdata	Serial	Input	Binary serial data input. Input data entered MSB first.
	D <sub>5</sub>	Parallel	Input	Parallel data bus bit5.
	M <sub>5</sub>	Direct	Input	M Counter bit5.
9	Sclk	Serial	Input	Serial clock input. Sdata is clocked serially into the 20-bit primary register (E_WR “low”) or the 8-bit enhancement register (E_WR “high”) on the rising edge of Sclk.
	D <sub>6</sub>	Parallel	Input	Parallel data bus bit6.
	M <sub>6</sub>	Direct	Input	M Counter bit6.
10	FSELS	Serial	Input	Selects contents of primary register (FSELS=1) or secondary register (FSELS=0) for programming of internal counters while in Serial Interface Mode.
	D <sub>7</sub>	Parallel	Input	Parallel data bus bit7 (MSB).
	Pre_en	Direct	Input	Prescaler enable, active “low”. When “high”, F <sub>in</sub> bypasses the prescaler.
11	GND	ALL		Ground.
12	FSELP	Parallel	Input	Selects contents of primary register (FSELP=1) or secondary register (FSELP=0) for programming of internal counters while in Parallel Interface Mode.
	A <sub>0</sub>	Direct	Input	A Counter bit0 (LSB).
13	E_WR	Serial	Input	Enhancement register write enable. While E_WR is “high”, Sdata can be serially clocked into the enhancement register on the rising edge of Sclk.
		Parallel	Input	Enhancement register write. D[7:0] are latched into the enhancement register on the rising edge of E_WR.
	A <sub>1</sub>	Direct	Input	A Counter bit1.
14	M2_WR	Parallel	Input	M2 write. D[3:0] are latched into the primary register (R[5:4], M[8:7]) on the rising edge of M2_WR.
	A <sub>2</sub>	Direct	Input	A Counter bit2.
15	Smode	Serial, Parallel	Input	Selects serial bus interface mode (Bmode=0, Smode=1) or Parallel Interface Mode (Bmode=0, Smode=0).
	A <sub>3</sub>	Direct	Input	A Counter bit3 (MSB).
16	Bmode	ALL	Input	Selects direct interface mode (Bmode=1).
17,18	V <sub>DD</sub>	ALL	(Note 1)	Power supply input. Input may range from 2.85 V to 3.15 V. Bypassing recommended.
19	M1_WR	Parallel	Input	M1 write. D[7:0] are latched into the primary register (Pre_en, M[6:0]) on the rising edge of M1_WR.
20	A_WR	Parallel	Input	A write. D[7:0] are latched into the primary register (R[3:0], A[3:0]) on the rising edge of A_WR.
21	Hop_WR	Serial, Parallel	Input	Hop write. The contents of the primary register are latched into the secondary register on the rising edge of Hop_WR.
22	F <sub>in</sub>	ALL	Input	Prescaler input from the VCO. 3.0 GHz max frequency.

**Table 1. Pin Descriptions (continued)**

Pin No.	Pin Name	Interface Mode	Type	Description
23	$\overline{F_{in}}$	ALL	Input	Prescaler complementary input. A bypass capacitor should be placed as close as possible to this pin and be connected in series with a 50 $\Omega$ resistor directly to the ground plane.
24	GND	ALL		Ground.
25	$f_p$	ALL	Output	Monitor pin for main divider output. Switching activity can be disabled through enhancement register programming or by floating or grounding $V_{DD}$ pin 31.
26	$V_{DD-f_p}$	ALL	(Note 1)	$V_{DD}$ for $f_p$ . Can be left floating or connected to GND to disable the $f_p$ output.
27	Dout	Serial, Parallel	Output	Data Out. The MSEL signal and the raw prescaler output are available on Dout through enhancement register programming.
28	$V_{DD}$	ALL	(Note 1)	Power supply input. Input may range from 2.85 V to 3.15 V. Bypassing recommended.
29	Cext	ALL	Output	Logical "NAND" of $PD_{\overline{D}}$ and $PD_{\overline{U}}$ terminated through an on chip, 2 k $\Omega$ series resistor. Connecting Cext to an external capacitor will low pass filter the input to the inverting amplifier used for driving LD.
30	$V_{DD}$	ALL	(Note 1)	Power supply input. Input may range from 2.85 V to 3.15 V. Bypassing recommended.
32	$PD_{\overline{D}}$	ALL	Output	$PD_{\overline{D}}$ is pulse down when $f_p$ leads $f_c$ .
33	$PD_{\overline{U}}$	ALL		$PD_{\overline{U}}$ is pulse down when $f_c$ leads $f_p$ .
34	NC	ALL		No connection.
35	$V_{DD-f_c}$	ALL	(Note 1)	$V_{DD}$ for $f_c$ can be left floating or connected to GND to disable the $f_c$ output.
36	$f_c$	ALL	Output	Monitor pin for reference divider output. Switching activity can be disabled through enhancement register programming or by floating or grounding $V_{DD}$ pin 38.
31,37	GND	ALL		Ground.
38,39	GND	ALL		Ground.
40	$f_r$	ALL	Input	Reference frequency input.
41	LD	ALL	Output	Lock detect and open drain logical inversion of CEXT. When the loop is in lock, LD is high impedance, otherwise LD is a logic low ("0").
42	$\overline{Enh}$	Serial, Parallel	Input	Enhancement mode. When asserted low ("0"), enhancement register bits are functional.
43	$V_{DD}$	ALL	(Note 1)	Power supply input. Input may range from 2.85 V to 3.15 V. Bypassing recommended.
44	$R_0$	Direct	Input	R Counter bit0 (LSB).
45	$R_1$	Direct	Input	R Counter bit1.
46	$R_2$	Direct	Input	R Counter bit2.
47	$R_3$	Direct	Input	R Counter bit3.
48	GND	ALL	(Note 1)	Ground.

Notes: 1. All  $V_{DD}$  pins are connected by diodes and must be supplied with the same positive voltage level.

$V_{DD-f_p}$  and  $V_{DD-f_c}$  are used to power the  $f_p$  and  $f_c$  outputs and can alternatively be left floating or connected to GND to disable the  $f_p$  and  $f_c$  outputs.

2. All digital input pins have 70 k $\Omega$  pull-down resistors to ground.

**Table 2. Absolute Maximum Ratings**

Symbol	Parameter/Conditions	Min	Max	Units
$V_{DD}$	Supply voltage	-0.3	4.0	V
$V_I$	Voltage on any input	-0.3	$V_{DD} + 0.3$	V
$I_I$	DC into any input	-10	+10	mA
$I_O$	DC into any output	-10	+10	mA
$T_{stg}$	Storage temperature range	-65	150	°C

**Table 3. Operating Ratings**

Symbol	Parameter/Conditions	Min	Max	Units
$V_{DD}$	Supply voltage	2.85	3.15	V
$T_A$	Operating ambient temperature range	-40	85	°C

### Moisture Sensitivity Level

The Moisture Sensitivity Level rating for the PE3336 is MSL3.

**Table 4. ESD Ratings**

Symbol	Parameter/Conditions	Level	Units
$V_{ESD}$	ESD voltage (Human Body Model)	1000	V

Note: Periodically sampled, not 100% tested. Tested per MIL-STD-883, M3015 C2

### Electrostatic Discharge (ESD) Precautions

When handling this UltraCMOS™ device, observe the same precautions that you would use with other ESD-sensitive devices. Although this device contains circuitry to protect it from damage due to ESD, precautions should be taken to avoid exceeding the specified rating in *Table 4*.

### Latch-Up Avoidance

Unlike conventional CMOS devices, UltraCMOS™ devices are immune to latch-up.

**Table 5. DC Characteristics:**  $V_{DD} = 3.0\text{ V}$ ,  $-40\text{ °C} < T_A < 85\text{ °C}$ , unless otherwise specified

Symbol	Parameter	Conditions	Min	Typ	Max	Units
$I_{DD}$	Operational supply current; Prescaler disabled Prescaler enabled	$V_{DD} = 2.85\text{ to }3.15\text{ V}$		10 19	26	mA mA
Digital Inputs: All except $f_r$ , $R_0$ , $F_{in}$ , $\bar{F}_{in}$						
$V_{IH}$	High level input voltage	$V_{DD} = 2.85\text{ to }3.15\text{ V}$	$0.7 \times V_{DD}$			V
$V_{IL}$	Low level input voltage	$V_{DD} = 2.85\text{ to }3.15\text{ V}$			$0.3 \times V_{DD}$	V
$I_{IH}$	High level input current	$V_{IH} = V_{DD} = 3.15\text{ V}$			+70	μA
$I_{IL}$	Low level input current	$V_{IL} = 0, V_{DD} = 3.15\text{ V}$	-1			μA
Reference Divider input: $f_r$						
$I_{IHR}$	High level input current	$V_{IH} = V_{DD} = 3.15\text{ V}$			100	μA
$I_{ILR}$	Low level input current	$V_{IL} = 0, V_{DD} = 3.15\text{ V}$	-100			μA
R0 Input (Pull-up Resistor): $R_0$						
$I_{IHRO}$	High level input current	$V_{IH} = V_{DD} = 3.15\text{ V}$			5	μA
$I_{ILRO}$	Low level input current	$V_{IL} = 0, V_{DD} = 3.15\text{ V}$	-5			μA
Counter and phase detector outputs: $f_c$ , $f_p$ , $PD_{\bar{D}}$ , $PD_{\bar{U}}$						
$V_{OLD}$	Output voltage LOW	$I_{out} = 6\text{ mA}$			0.4	V
$V_{OHD}$	Output voltage HIGH	$I_{out} = -3\text{ mA}$	$V_{DD} - 0.4$			V
Lock detect outputs: $C_{ext}$ , LD						
$V_{OLC}$	Output voltage LOW, $C_{ext}$	$I_{out} = 100\text{ mA}$			0.4	V
$V_{OHC}$	Output voltage HIGH, $C_{ext}$	$I_{out} = -100\text{ mA}$	$V_{DD} - 0.4$			V
$V_{OLLD}$	Output voltage LOW, LD	$I_{out} = 6\text{ mA}$			0.4	V

**Table 6. AC Characteristics:**  $V_{DD} = 3.0\text{ V}$ ,  $-40^{\circ}\text{ C} < T_A < 85^{\circ}\text{ C}$ , unless otherwise specified

Symbol	Parameter	Conditions	Min	Max	Units
Control Interface and Latches (see <i>Figures 3, 4, 5</i> )					
$f_{\text{Clk}}$	Serial data clock frequency			10	MHz
$t_{\text{ClkH}}$	Serial clock HIGH time		30		ns
$t_{\text{ClkL}}$	Serial clock LOW time		30		ns
$t_{\text{DSU}}$	Sdata set-up time after Sclk rising edge, D[7:0] set-up time to M1_WR, M2_WR, A_WR, E_WR rising edge		10		ns
$t_{\text{DHLD}}$	Sdata hold time after Sclk rising edge, D[7:0] hold time to M1_WR, M2_WR, A_WR, E_WR rising edge		10		ns
$t_{\text{PW}}$	S_WR, M1_WR, M2_WR, A_WR, E_WR pulse width		30		ns
$t_{\text{CWR}}$	Sclk rising edge to S_WR rising edge. S_WR, M1_WR, M2_WR, A_WR falling edge to Hop_WR rising edge		30		ns
$t_{\text{CE}}$	Sclk falling edge to E_WR transition		30		ns
$t_{\text{WRC}}$	S_WR falling edge to Sclk rising edge. Hop_WR falling edge to S_WR, M1_WR, M2_WR, A_WR rising edge		30		ns
$t_{\text{EC}}$	E_WR transition to Sclk rising edge		30		ns
$t_{\text{MDO}}$	MSEL data out delay after Fin rising edge	$C_L = 12\text{ pf}$		8	ns
Main Divider (Including Prescaler)					
$F_{\text{in}}$	Operating frequency		500	3000	MHz
$P_{\text{Fin}}$	Input level range	External AC coupling	-5	5	dBm
Main Divider (Prescaler Bypassed)					
$F_{\text{in}}$	Operating frequency		50	300	MHz
$P_{\text{Fin}}$	Input level range	External AC coupling	-5	5	dBm
Reference Divider					
$f_r$	Operating frequency	(Note 1)	(Note 2)	100	MHz
$P_{\text{fr}}$	Reference input power	Single ended input	-2	10	dBm
$V_{\text{fr}}$	Input sensitivity	External AC coupling (Note 3)	0.5		$V_{\text{P-P}}$
Phase Detector					
$f_c$	Comparison frequency	(Note 1)		20	MHz

Notes: 1. Parameter is guaranteed through characterization only and is not tested.

2. Running at low frequencies (< 10 MHz sinewave), the device will still be functional but may cause phase noise degradation. Inserting a low-noise amplifier to square up the edges is recommended at lower input frequencies.

3. CMOS logic levels may be used if DC coupled. For optimum phase noise performance, the reference input falling edge rate should be faster than 80mV/ns.

### Functional Description

The PE3336 consists of a prescaler, counters, a phase detector and control logic. The dual modulus prescaler divides the VCO frequency by either 10 or 11, depending on the value of the modulus select. Counters “R” and “M” divide the reference and prescaler output, respectively, by integer values stored in a 20-bit register. An additional counter (“A”) is used in the modulus select logic. The phase-frequency detector

generates up and down frequency control signals. The control logic includes a selectable chip interface. Data can be written via serial bus, parallel bus, or hardwired direct to the pins. There are also various operational and test modes and lock detect.

Figure 3. Functional Block Diagram

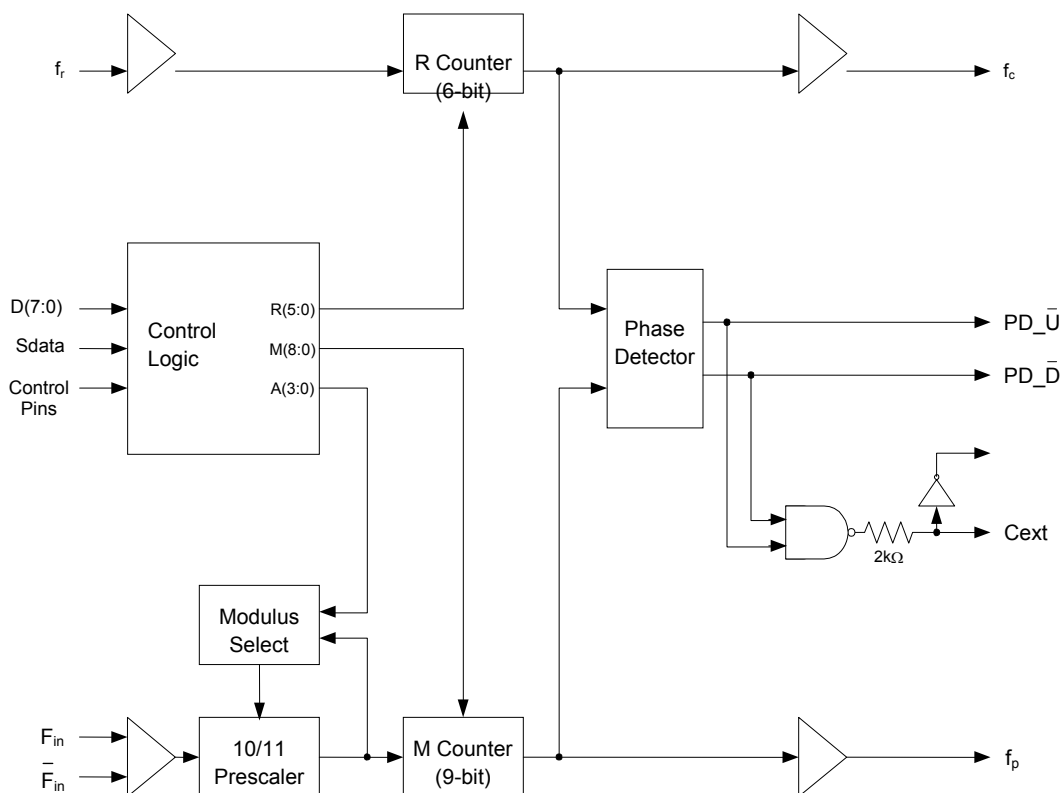

## Main Counter Chain

The main counter chain divides the RF input frequency,  $F_{in}$ , by an integer derived from the user defined values in the “M” and “A” counters. It is composed of the 10/11 dual modulus prescaler, modulus select logic, and 9-bit M counter. Setting  $\overline{Pre\_en}$  “low” enables the 10/11 prescaler. Setting  $\overline{Pre\_en}$  “high” allows  $F_{in}$  to bypass the prescaler and powers down the prescaler.

The output from the main counter chain,  $f_p$ , is related to the VCO frequency,  $F_{in}$ , by the following equation:

$$f_p = F_{in} / [10 \times (M + 1) + A] \quad (1)$$

where  $A \leq M + 1$ ,  $1 \leq M \leq 511$

When the loop is locked,  $F_{in}$  is related to the reference frequency,  $f_r$ , by the following equation:

$$F_{in} = [10 \times (M + 1) + A] \times (f_r / (R+1)) \quad (2)$$

where  $A \leq M + 1$ ,  $1 \leq M \leq 511$

A consequence of the upper limit on A is that  $F_{in}$  must be greater than or equal to  $90 \times (f_r / (R+1))$  to obtain contiguous channels. Programming the M Counter with the minimum value of “1” will result in a minimum M Counter divide ratio of “2”.

When the prescaler is bypassed, the equation becomes:

$$F_{in} = (M + 1) \times (f_r / (R+1)) \quad (3)$$

where  $1 \leq M \leq 511$

In Direct Interface Mode, main counter inputs  $M_7$  and  $M_8$  are internally forced low.

## Reference Counter

The reference counter chain divides the reference frequency,  $f_r$ , down to the phase detector comparison frequency,  $f_c$ .

The output frequency of the 6-bit R Counter is related to the reference frequency by the following equation:

$$f_c = f_r / (R + 1) \quad (4)$$

where  $0 \leq R \leq 63$

Note that programming R equal to “0” will pass the reference frequency,  $f_r$ , directly to the phase detector.

In Direct Interface Mode, R Counter inputs  $R_4$  and  $R_5$  are internally forced low (“0”).

## Register Programming

### Parallel Interface Mode

Parallel Interface Mode is selected by setting the  $\overline{Bmode}$  input “low” and the  $\overline{Smode}$  input “low”.

Parallel input data,  $D[7:0]$ , are latched in a parallel fashion into one of three, 8-bit primary register sections on the rising edge of  $M1\_WR$ ,  $M2\_WR$ , or  $A\_WR$  per the mapping shown in *Table 7* on page 10. The contents of the primary register are transferred into a secondary register on the rising edge of  $Hop\_WR$  according to the timing diagram shown in *Figure 4*. Data are transferred to the counters as shown in *Table 7* on page 10.

The secondary register acts as a buffer to allow rapid changes to the VCO frequency. This double buffering for “ping-pong” counter control is programmed via the FSELP input. When FSELP is “high”, the primary register contents set the counter inputs. When FSELP is “low”, the secondary register contents are utilized.

Parallel input data,  $D[7:0]$ , are latched into the enhancement register on the rising edge of  $E\_WR$  according to the timing diagram shown in *Figure 4*. This data provides control bits as shown in *Table 8* on page 10 with bit functionality enabled by asserting the  $\overline{EnH}$  input “low”.

### Serial Interface Mode

Serial Interface Mode is selected by setting the  $\overline{Bmode}$  input “low” and the  $\overline{Smode}$  input “high”.

While the  $E\_WR$  input is “low” and the  $S\_WR$  input is “low”, serial input data ( $Sdata$  input),  $B_0$  to  $B_{19}$ , are clocked serially into the primary register on the rising edge of  $Sclk$ , MSB ( $B_0$ ) first. The contents from the primary register are transferred into the secondary register on the rising edge of either  $S\_WR$  or  $Hop\_WR$  according to the timing diagram shown in *Figures 4-5*. Data are transferred to the counters as shown in *Table 7* on page 10.

The double buffering provided by the primary and secondary registers allows for “ping-pong” counter control using the FSELS input. When FSELS is “high”, the primary register contents set the counter inputs. When FSELS is “low”, the secondary register contents are utilized.

While the  $E\_WR$  input is “high” and the  $S\_WR$



input is “low”, serial input data (Sdata input), B<sub>0</sub> to B<sub>7</sub>, are clocked serially into the enhancement register on the rising edge of Sclk, MSB (B<sub>0</sub>) first. The enhancement register is double buffered to prevent inadvertent control changes during serial loading, with buffer capture of the serially entered data performed on the falling edge of E\_WR according to the timing diagram shown in *Figure 5*. After the falling edge of E\_WR, the data provide control bits as shown in *Table 8* with bit functionality enabled by asserting the  $\overline{\text{Enh}}$  input “low”.

### Direct Interface Mode

Direct Interface Mode is selected by setting the  $\overline{\text{Bmode}}$  input “high”.

Counter control bits are set directly at the pins as shown in *Table 7*. In Direct Interface Mode, main counter inputs M<sub>7</sub> and M<sub>8</sub>, and R Counter inputs R<sub>4</sub> and R<sub>5</sub> are internally forced low (“0”).

**Table 7. Primary Register Programming**

Interface Mode	$\overline{\text{Enh}}$	$\overline{\text{Bmode}}$	$\overline{\text{Smode}}$	R <sub>5</sub>	R <sub>4</sub>	M <sub>8</sub>	M <sub>7</sub>	$\overline{\text{Pre\_en}}$	M <sub>6</sub>	M <sub>5</sub>	M <sub>4</sub>	M <sub>3</sub>	M <sub>2</sub>	M <sub>1</sub>	M <sub>0</sub>	R <sub>3</sub>	R <sub>2</sub>	R <sub>1</sub>	R <sub>0</sub>	A <sub>3</sub>	A <sub>2</sub>	A <sub>1</sub>	A <sub>0</sub>
Parallel	1	0	0	M2_WR rising edge load				M1_WR rising edge load								A_WR rising edge load							
				D <sub>3</sub>	D <sub>2</sub>	D <sub>1</sub>	D <sub>0</sub>	D <sub>7</sub>	D <sub>6</sub>	D <sub>5</sub>	D <sub>4</sub>	D <sub>3</sub>	D <sub>2</sub>	D <sub>1</sub>	D <sub>0</sub>	D <sub>7</sub>	D <sub>6</sub>	D <sub>5</sub>	D <sub>4</sub>	D <sub>3</sub>	D <sub>2</sub>	D <sub>1</sub>	D <sub>0</sub>
Serial*	1	0	1	B <sub>0</sub>	B <sub>1</sub>	B <sub>2</sub>	B <sub>3</sub>	B <sub>4</sub>	B <sub>5</sub>	B <sub>6</sub>	B <sub>7</sub>	B <sub>8</sub>	B <sub>9</sub>	B <sub>10</sub>	B <sub>11</sub>	B <sub>12</sub>	B <sub>13</sub>	B <sub>14</sub>	B <sub>15</sub>	B <sub>16</sub>	B <sub>17</sub>	B <sub>18</sub>	B <sub>19</sub>
Direct	1	1	X	0	0	0	0	$\overline{\text{Pre\_en}}$	M <sub>6</sub>	M <sub>5</sub>	M <sub>4</sub>	M <sub>3</sub>	M <sub>2</sub>	M <sub>1</sub>	M <sub>0</sub>	R <sub>3</sub>	R <sub>2</sub>	R <sub>1</sub>	R <sub>0</sub>	A <sub>3</sub>	A <sub>2</sub>	A <sub>1</sub>	A <sub>0</sub>

\*Serial data clocked serially on Sclk rising edge while E\_WR “low” and captured in secondary register on S\_WR rising edge.

↑  
MSB (first in)

(last in) LSB ↑

**Table 8. Enhancement Register Programming**

Interface Mode	$\overline{\text{Enh}}$	$\overline{\text{Bmode}}$	$\overline{\text{Smode}}$	Reserved	Reserved	Reserved	Power down	Counter load	MSEL output	Prescaler output	f <sub>c</sub> , f <sub>p</sub> OE		
Parallel	0	X	0	E_WR rising edge load									
				D <sub>7</sub>	D <sub>6</sub>	D <sub>5</sub>	D <sub>4</sub>	D <sub>3</sub>	D <sub>2</sub>	D <sub>1</sub>	D <sub>0</sub>		
Serial*	0	X	1	B <sub>0</sub>	B <sub>1</sub>	B <sub>2</sub>	B <sub>3</sub>	B <sub>4</sub>	B <sub>5</sub>	B <sub>6</sub>	B <sub>7</sub>		

\*Serial data clocked serially on Sclk rising edge while E\_WR “high” and captured in the double buffer on E\_WR falling edge.

↑  
MSB (first in)

(last in) LSB ↑

Figure 4. Parallel Interface Mode Timing Diagram

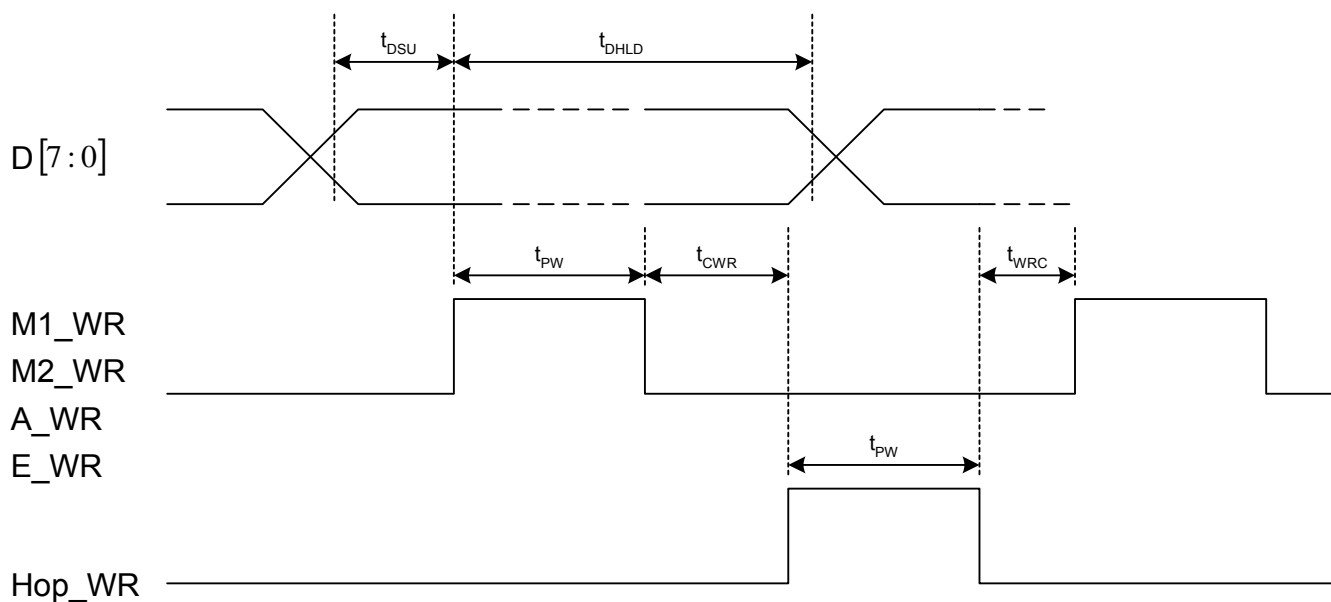
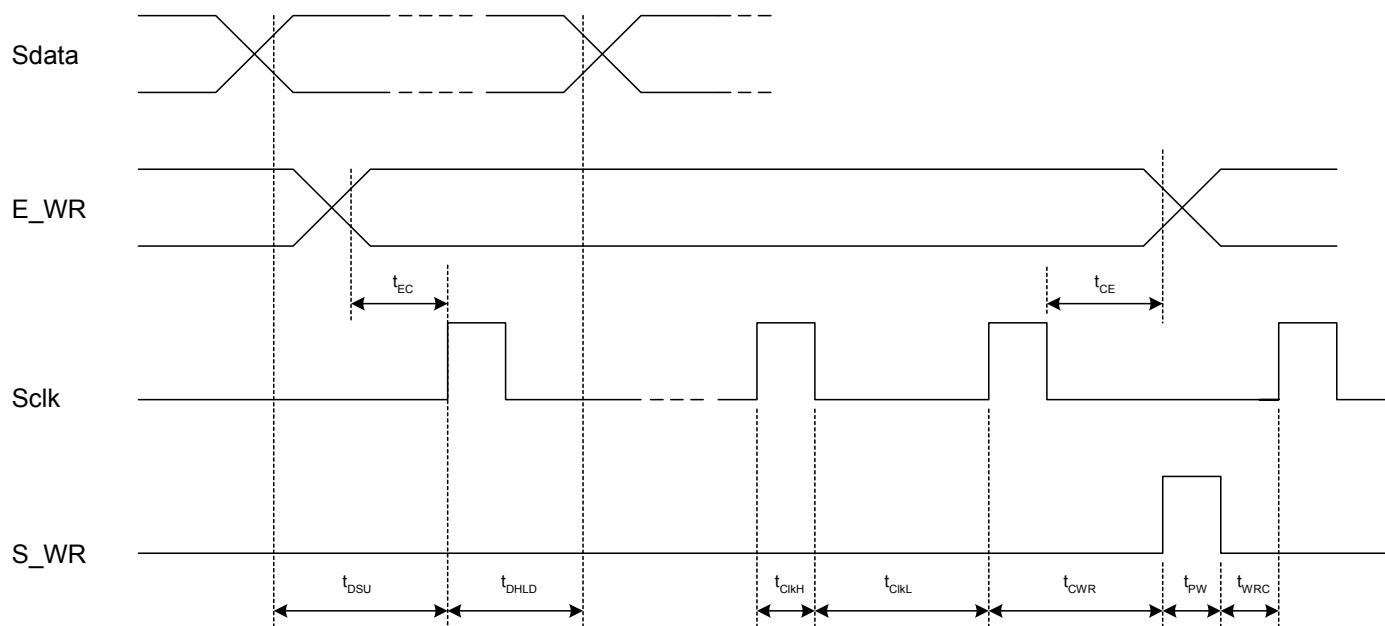

Figure 5. Serial Interface Mode Timing Diagram



## Enhancement Register

The functions of the enhancement register bits are shown below with all bits active “high”.

**Table 9. Enhancement Register Bit Functionality**

Bit Function		Description
Bit 0	Reserved**	
Bit 1	Reserved**	
Bit 2	Reserved**	
Bit 3	Power down	Power down of all functions except programming interface.
Bit 4	Counter load	Immediate and continuous load of counter programming as directed by the $\overline{\text{Bmode}}$ and $\overline{\text{Smode}}$ inputs.
Bit 5	MSEL output	Drives the internal dual modulus prescaler modulus select (MSEL) onto the Dout output.
Bit 6	Prescaler output	Drives the raw internal prescaler output onto the Dout output.
Bit 7	$f_p, f_c \overline{\text{OE}}$	$f_p, f_c$ outputs disabled.

\*\* Program to 0

## Phase Detector

The phase detector is triggered by rising edges from the main Counter ( $f_p$ ) and the reference counter ( $f_c$ ). It has two outputs,  $\text{PD}_{\overline{\text{U}}}$  and  $\text{PD}_{\overline{\text{D}}}$ . If the divided VCO leads the divided reference in phase or frequency ( $f_p$  leads  $f_c$ ),  $\text{PD}_{\overline{\text{D}}}$  pulses “low”. If the divided reference leads the divided VCO in phase or frequency ( $f_c$  leads  $f_p$ ),  $\text{PD}_{\overline{\text{U}}}$  pulses “low”. The width of either pulse is directly proportional to phase offset between the two input signals,  $f_p$  and  $f_c$ .

The phase detector gain is equal to  $2.7 \text{ V} / 2 \pi$ , which numerically yields  $0.43 \text{ V} / \text{radian}$ .

$\text{PD}_{\overline{\text{U}}}$  and  $\text{PD}_{\overline{\text{D}}}$  drive an active loop filter which controls the VCO tune voltage.  $\text{PD}_{\overline{\text{U}}}$  pulses result in an increase in VCO frequency;  $\text{PD}_{\overline{\text{D}}}$  pulses result in a decrease in VCO frequency (for a positive  $K_v$  VCO).

A lock detect output, LD is also provided, via the pin Cext. Cext is the logical “NAND” of  $\text{PD}_{\overline{\text{U}}}$  and  $\text{PD}_{\overline{\text{D}}}$  waveforms, which is driven through a series  $2 \text{ k}\Omega$  resistor. Connecting Cext to an external shunt capacitor provides low pass filtering of this signal. Cext also drives the input of an internal inverting comparator with an open drain output. Thus LD is an “AND” function of  $\text{PD}_{\overline{\text{U}}}$  and  $\text{PD}_{\overline{\text{D}}}$ .

**Figure 6. Package Drawing**

Green 48-lead QFN

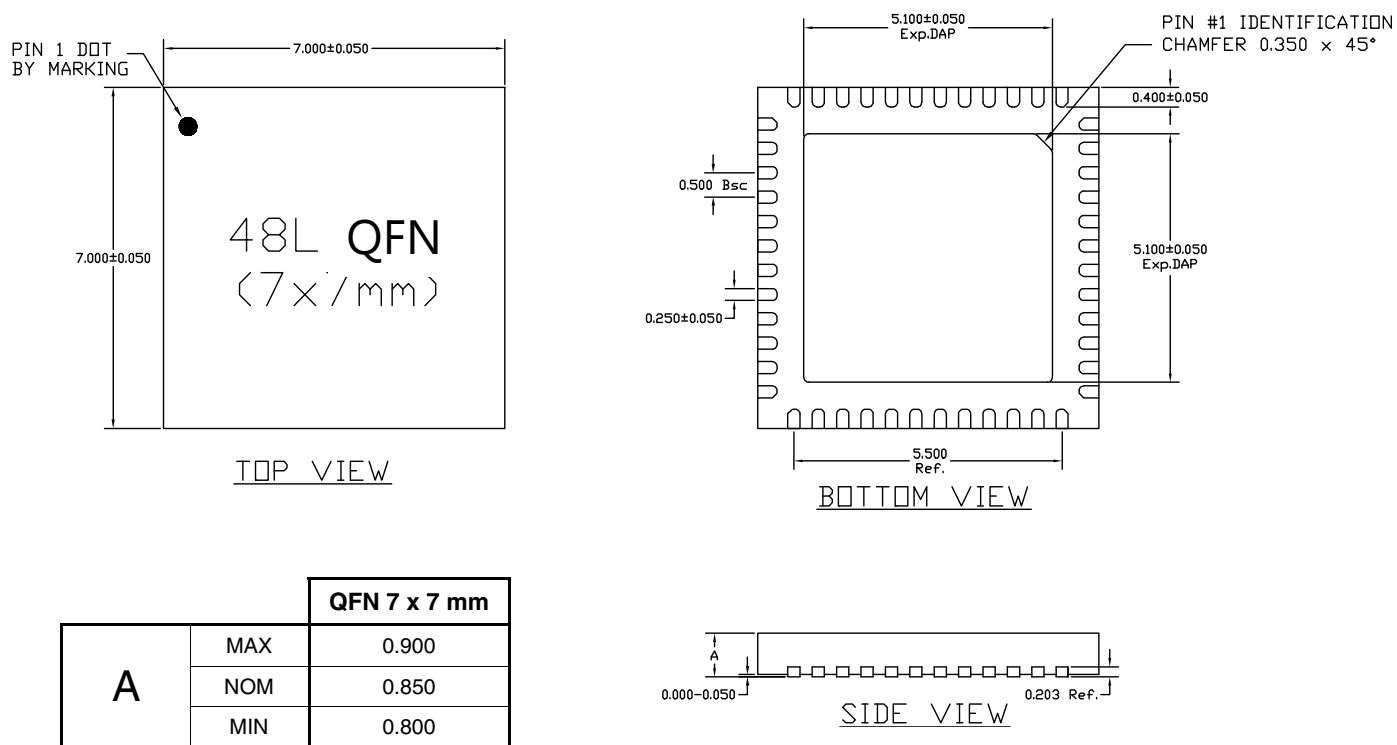

Dimensions are in mm. Tolerances as shown.

**Figure 7. Tape and Reel Drawing**  
Green 48-lead QFN

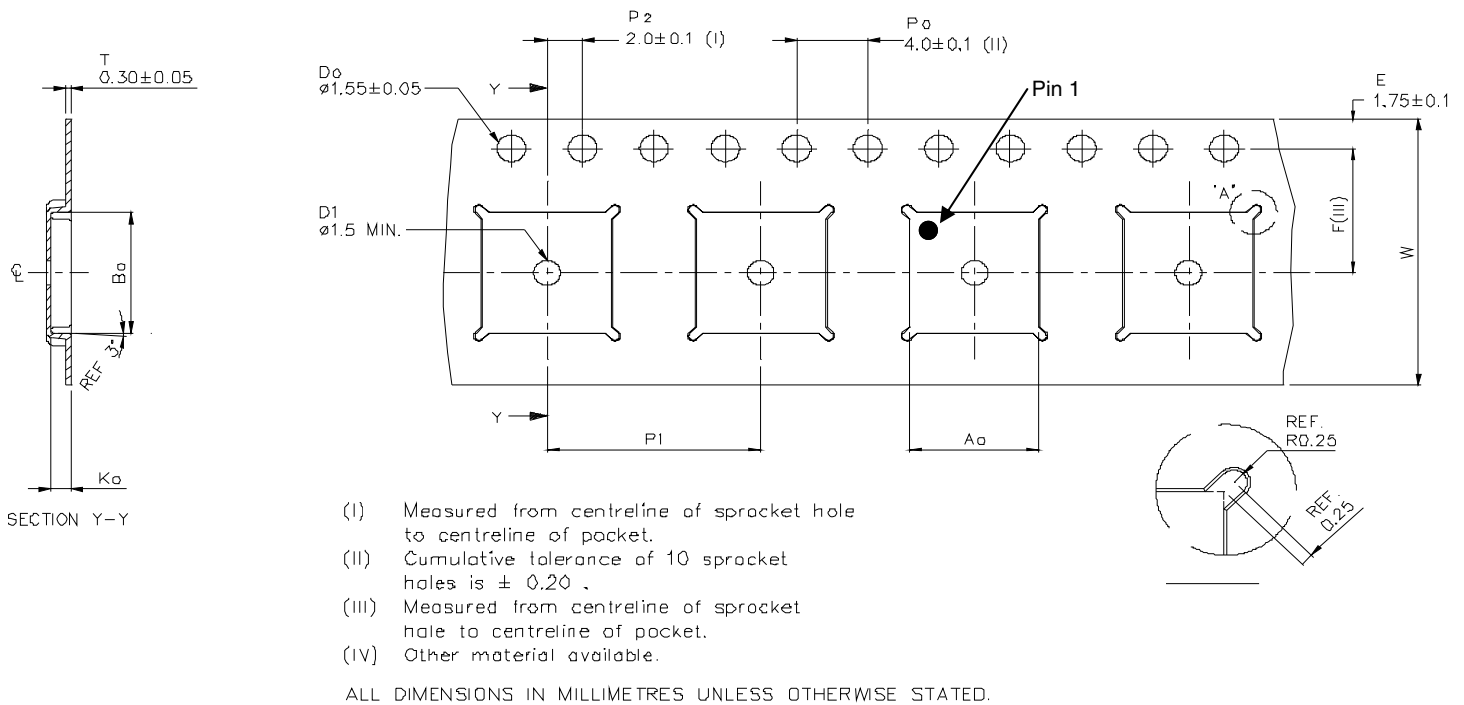

**Table 10. Ordering Information**

Order Code	Part Marking	Description	Package	Shipping Method
3336-53	PE3336	PE3336G-48QFN 7 x 7 mm-52A	Green 48-lead 7 x 7 mm QFN	52 units / Tube or cut tape
3336-52	PE3336	PE3336G-48QFN 7 x 7 mm-2000C	Green 48-lead 7 x 7 mm QFN	2000 units / T&R
3336-01	PE3336EK	PE3336-48QFN 7 x 7 mm-EK	Evaluation Kit	1 / Box

## Sales Contact and Information

For Sales and contact information please visit [www.psemi.com](http://www.psemi.com).

**Advance Information:** The product is in a formative or design stage. The datasheet contains design target specifications for product development. Specifications and features may change in any manner without notice. **Preliminary Specification:** The datasheet contains preliminary data. Additional data may be added at a later date. Peregrine reserves the right to change specifications at any time without notice in order to supply the best possible product. **Product Specification:** The datasheet contains final data. In the event Peregrine decides to change the specifications, Peregrine will notify customers of the intended changes by issuing a CNF (Customer Notification Form).

The information in this datasheet is believed to be reliable. However, Peregrine assumes no liability for the use of this information. Use shall be entirely at the user's own risk.

No patent rights or licenses to any circuits described in this datasheet are implied or granted to any third party.

Peregrine's products are not designed or intended for use in devices or systems intended for surgical implant, or in other applications intended to support or sustain life, or in any application in which the failure of the Peregrine product could create a situation in which personal injury or death might occur. Peregrine assumes no liability for damages, including consequential or incidental damages, arising out of the use of its products in such applications.

The Peregrine name, logo, and UTSi are registered trademarks and UltraCMOS, HaRP, MultiSwitch and DuNE are trademarks of Peregrine Semiconductor Corp.