

---

**8-bit ultra-low-power microcontroller with up to 8-Kbyte Flash memory, multifunction timers, comparators, UART, SPI, I2C**

---

Datasheet - production data

**Features**

- Main microcontroller features
  - Supply voltage range 1.8 V to 3.6 V
  - Low power consumption (Halt: 0.3  $\mu$ A, Active-halt: 0.8  $\mu$ A, Dynamic Run: 150  $\mu$ A/MHz)
  - STM8 Core with up to 16 CISC MIPS throughput
  - Temp. range: -40 to 125 °C
- Memories
  - 8 Kbytes of Flash program including up to 2 Kbytes of data EEPROM
  - Error correction code (ECC)
  - Flexible write and read protection modes
  - In-application and in-circuit programming
  - Data EEPROM capability
  - 1.5 Kbytes of static RAM
- Clock management
  - Internal 16 MHz RC with fast wakeup time (typ. 4  $\mu$ s)
  - Internal low consumption 38 kHz RC driving both the IWDG and the AWU
- Reset and supply management
  - Ultra-low power POR/PDR
  - Three low-power modes: Wait, Active-halt, Halt
- Interrupt management
  - Nested interrupt controller with software priority control
  - Up to 6 external interrupt sources
- I/Os
  - Up to 6 I/Os, all mappable on external interrupt vectors
  - I/Os with programmable input pull-ups, high sink/source capability and one LED driver infrared output

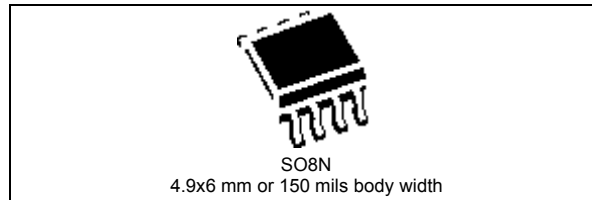

- Peripherals
  - Two 16-bit general purpose timers (TIM2 and TIM3) with up and down counter and 1 channel (used as IC, OC, PWM)
  - One 8-bit timer (TIM4) with 7-bit prescaler
  - Infrared remote control (IR)
  - Independent watchdog
  - Auto-wakeup unit
  - Beeper timer with 1, 2 or 4 kHz frequencies
  - SPI synchronous serial interface
  - Fast I2C Multimaster/slave 400 kHz
  - UART with fractional baud rate generator
  - 2 comparators with 1 input each
- Development support
  - Hardware single wire interface module (SWIM) for fast on-chip programming and non intrusive debugging

---

<b>1</b>	<b>Introduction</b> .....	<b>6</b>
<b>2</b>	<b>Description</b> .....	<b>7</b>
<b>3</b>	<b>Product overview</b> .....	<b>8</b>
3.1	Central processing unit STM8 .....	9
3.2	Development tools .....	9
3.3	Single wire data interface (SWIM) and debug module .....	9
3.4	Interrupt controller .....	9
3.5	Memory .....	10
3.6	Low power modes .....	11
3.7	Voltage regulators .....	11
3.8	Clock control .....	11
3.9	Independent watchdog .....	11
3.10	Auto-wakeup counter .....	11
3.11	General purpose and basic timers .....	11
3.12	Beeper .....	12
3.13	Infrared (IR) interface .....	12
3.14	Comparators .....	12
3.15	USART .....	12
3.16	SPI .....	12
3.17	I2C .....	13
<b>4</b>	<b>Pin description</b> .....	<b>14</b>
<b>5</b>	<b>Memory and register map</b> .....	<b>17</b>
<b>6</b>	<b>Interrupt vector mapping</b> .....	<b>26</b>
<b>7</b>	<b>Option bytes</b> .....	<b>28</b>
<b>8</b>	<b>Electrical parameters</b> .....	<b>30</b>
8.1	Parameter conditions .....	30
8.1.1	Minimum and maximum values .....	30
8.1.2	Typical values .....	30
8.1.3	Typical curves .....	30

8.1.4	Loading capacitor	30
8.1.5	Pin input voltage	31
8.2	Absolute maximum ratings	31
8.3	Operating conditions	33
8.3.1	General operating conditions	33
8.3.2	Power-up / power-down operating conditions	34
8.3.3	Supply current characteristics	34
8.3.4	Clock and timing characteristics	38
8.3.5	Memory characteristics	40
8.3.6	I/O port pin characteristics	41
8.3.7	Communication interfaces	46
8.3.8	Comparator characteristics	50
8.3.9	EMC characteristics	51
8.4	Thermal characteristics	53
<b>9</b>	<b>Package information</b>	<b>54</b>
9.1	SO8N package information	54
<b>10</b>	<b>Ordering information</b>	<b>57</b>
<b>11</b>	<b>Revision history</b>	<b>58</b>

## List of tables

Table 1.	STM8L001J3 device feature summary	7
Table 2.	Legend/abbreviation for table 4	14
Table 3.	STM8L001J3 pin description	15
Table 4.	Flash and RAM boundary addresses	18
Table 5.	I/O Port hardware register map	18
Table 6.	General hardware register map	19
Table 7.	CPU/SWIM/debug module/interrupt controller registers	24
Table 8.	Interrupt mapping	26
Table 9.	Option bytes	28
Table 10.	Option byte description	28
Table 11.	Voltage characteristics	31
Table 12.	Current characteristics	32
Table 13.	Thermal characteristics	32
Table 14.	General operating conditions	33
Table 15.	Operating conditions at power-up / power-down	34
Table 16.	Total current consumption in Run mode	35
Table 17.	Total current consumption in Wait mode	36
Table 18.	Total current consumption and timing in Halt and Active-halt mode at VDD = 1.8 V to 3.6 V	37
Table 19.	Peripheral current consumption	38
Table 20.	HSI oscillator characteristics	38
Table 21.	LSI oscillator characteristics	40
Table 22.	RAM and hardware registers	40
Table 23.	Flash program memory	40
Table 24.	I/O static characteristics	41
Table 25.	Output driving current (High sink ports)	44
Table 26.	Output driving current (true open drain ports)	44
Table 27.	Output driving current (PA0 with high sink LED driver capability)	44
Table 28.	SPI characteristics	46
Table 29.	I2C characteristics	49
Table 30.	Comparator characteristics	50
Table 31.	EMS data	51
Table 32.	EMI data	52
Table 33.	ESD absolute maximum ratings	52
Table 34.	Electrical sensitivities	53
Table 35.	Thermal characteristics	53
Table 36.	SO8N – 8-lead 4.9 x 6 mm, plastic small outline, 150 mils body width, package mechanical data	54
Table 37.	Ordering information scheme	57
Table 38.	Document revision history	58

## List of figures

Figure 1.	STM8L001J3 device block diagram	8
Figure 2.	STM8L001J3 SO8N pinout	14
Figure 3.	Memory map	17
Figure 4.	Pin loading conditions	30
Figure 5.	Pin input voltage	31
Figure 6.	IDD(RUN) vs. VDD, fCPU = 2 MHz	35
Figure 7.	IDD(RUN) vs. VDD, fCPU = 16 MHz	35
Figure 8.	IDD(WAIT) vs. VDD, fCPU = 2 MHz	36
Figure 9.	IDD(WAIT) vs. VDD, fCPU = 16 MHz	36
Figure 10.	Typ. IDD(Halt) vs. VDD, fCPU = 2 MHz and 16 MHz	37
Figure 11.	Typical HSI frequency vs. V <sub>DD</sub>	39
Figure 12.	Typical HSI accuracy vs. temperature, V <sub>DD</sub> = 3 V	39
Figure 13.	Typical HSI accuracy vs. temperature, VDD = 1.8 V to 3.6 V	39
Figure 14.	Typical LSI RC frequency vs. VDD	40
Figure 15.	Typical VIL and VIH vs. VDD (High sink I/Os)	42
Figure 16.	Typical VIL and VIH vs. VDD (true open drain I/Os)	42
Figure 17.	Typical pull-up resistance R <sub>PU</sub> vs. V <sub>DD</sub> with VIN=VSS	43
Figure 18.	Typical pull-up current I <sub>PU</sub> vs. V <sub>DD</sub> with VIN=VSS	43
Figure 19.	Typ. VOL at VDD = 3.0 V (High sink ports)	45
Figure 20.	Typ. VOL at VDD = 1.8 V (High sink ports)	45
Figure 21.	Typ. VOL at VDD = 3.0 V (true open drain ports)	45
Figure 22.	Typ. VOL at VDD = 1.8 V (true open drain ports)	45
Figure 23.	Typ. VDD - VOH at VDD = 3.0 V (High sink ports)	45
Figure 24.	Typ. VDD - VOH at VDD = 1.8 V (High sink ports)	45
Figure 25.	SPI timing diagram - slave mode and CPHA = 0	47
Figure 26.	SPI timing diagram - slave mode and CPHA = 1 <sup>(1)</sup>	47
Figure 27.	SPI timing diagram - master mode <sup>(1)</sup>	48
Figure 28.	Typical application with I2C bus and timing diagram (1)	50
Figure 29.	SO8N – 8-lead, 4.9 x 6 mm, plastic small outline, 150 mils body width, package outline	54
Figure 30.	SO8N – 8-lead 4.9 x 6 mm, plastic small outline, 150 mils body width, package recommended footprint	55
Figure 31.	Example of SO8N marking (package top view)	56

# 1 Introduction

This datasheet provides the STM8L001J3 pinout, ordering information, mechanical and electrical device characteristics.

For complete information on the STM8L001J3 microcontroller memory, registers and peripherals, please refer to the *STM8L001xx, STM8L101xx microcontroller family* reference manual (RM0013).

The STM8L001J3 devices are members of the STM8L low-power 8-bit family. They are referred to as low-density devices in the *STM8L001xx, STM8L101xx microcontroller family* reference manual (RM0013) and in the *How to program STM8L and STM8AL Flash program memory and data EEPROM* programming manual (PM0054).

All devices of the SM8L Series provide the following benefits:

- Reduced system cost
  - 8 Kbytes of low-density embedded Flash program memory including up to 2 Kbytes of data EEPROM
  - High system integration level with internal clock oscillators and watchdogs.
  - Smaller battery and cheaper power supplies.
- Low power consumption and advanced features
  - Up to 16 MIPS at 16 MHz CPU clock frequency
  - Less than 150  $\mu\text{A}/\text{MHz}$ , 0.8  $\mu\text{A}$  in Active-halt mode, and 0.3  $\mu\text{A}$  in Halt mode
  - Clock gated system and optimized power management
- Short development cycles
  - Application scalability across a common family product architecture with compatible pinout, memory map and modular peripherals.
  - Full documentation and a wide choice of development tools
- Product longevity
  - Advanced core and peripherals made in a state-of-the art technology
  - Product family operating from 1.8 V to 3.6 V supply.

## 2 Description

The STM8L001J3 low-power microcontroller features the enhanced STM8 CPU core providing increased processing power (up to 16 MIPS at 16 MHz) while maintaining the advantages of a CISC architecture with improved code density, a 24-bit linear addressing space and an optimized architecture for low power operations.

The family includes an integrated debug module with a hardware interface (SWIM) which allows non-intrusive in-application debugging and ultra fast Flash programming.

All STM8L001J3 microcontrollers feature low power low-voltage single-supply program Flash memory. The 8-Kbyte devices embed data EEPROM.

The STM8L001J3 low power microcontroller is based on a generic set of state-of-the-art peripherals. The modular design of the peripheral set allows the same peripherals to be found in different ST microcontroller families including 32-bit families. This makes any transition to a different family very easy, and simplified even more by the use of a common set of development tools.

All STM8L low power products are based on the same architecture with the same memory mapping and a coherent pinout.

**Table 1. STM8L001J3 device feature summary**

Features	STM8L001J3
Flash	8 Kbytes of Flash program memory including up to 2 Kbytes of Data EEPROM
RAM	1.5 Kbytes
Peripheral functions	Independent watchdog (IWDG), Auto-wakeup unit (AWU), Beep, Serial peripheral interface (SPI), Inter-integrated circuit (I2C), Universal synchronous / asynchronous receiver / transmitter (USART), 2 comparators, Infrared (IR) interface
Timers	Two 16-bit timers, one 8-bit timer
Operating voltage	1.8 to 3.6 V
Operating temperature	-40 to +125 °C
Packages	SO8N

### 3 Product overview

Figure 1. STM8L001J3 device block diagram

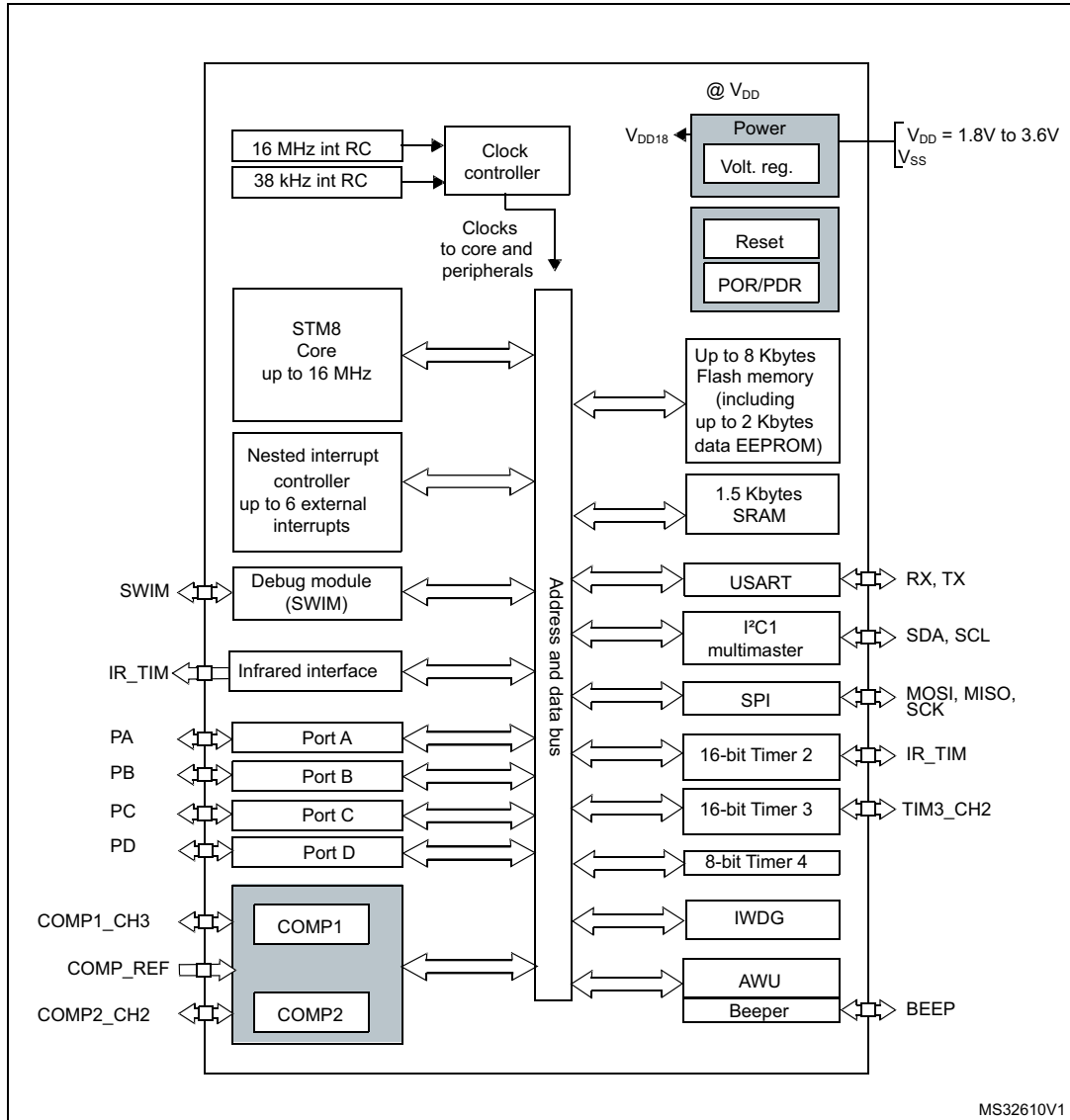

Legend:

- AWU: Auto-wakeup unit
- Int. RC: internal RC oscillator
- I<sup>2</sup>C: Inter-integrated circuit multimaster interface
- POR/PDR: Power on reset / power down reset
- SPI: Serial peripheral interface
- SWIM: Single wire interface module
- USART: Universal synchronous / asynchronous receiver / transmitter
- IWDG: Independent watchdog



### 3.1 Central processing unit STM8

The 8-bit STM8 core is designed for code efficiency and performance.

It features 21 internal registers, 20 addressing modes including indexed, indirect and relative addressing, and 80 instructions.

### 3.2 Development tools

Development tools for the STM8 microcontrollers include:

- The STVD high-level language debugger including C compiler, assembler and integrated development environment
- The STVP Flash programming software

The STM8 also comes with starter kits, evaluation boards and low-cost in-circuit debugging/programming tools.

### 3.3 Single wire data interface (SWIM) and debug module

The debug module with its single wire data interface (SWIM) permits non-intrusive real-time in-circuit debugging and fast memory programming.

The Single wire interface is used for direct access to the debugging module and memory programming. The interface can be activated in all device operation modes.

The non-intrusive debugging module features a performance close to a full-featured emulator. Beside memory and peripherals, also CPU operation can be monitored in real-time by means of shadow registers.

#### Recommendations for SWIM pin (pin#1)

As the NRST pin is not available on this device, if the SWIM pin should be used with the I/O pin functionality, it is recommended to add a ~5 seconds delay in the firmware before changing the functionality on the pin with SWIM functions. This action allows the user to set the device into SWIM mode after the device power on and to be able to reprogram the device. If the pin with SWIM functionality is set to I/O mode immediately after the device reset, the device is unable to connect through the SWIM interface and it gets locked forever. This initial delay can be removed in the final (locked) code.

If the initial delay is not acceptable for the application there is the option that the firmware reenables the SWIM pin functionality under specific conditions such as during firmware startup or during application run. Once that this procedure is done, the SWIM interface can be used for the device debug/programming.

### 3.4 Interrupt controller

The STM8L001J3 features a nested vectored interrupt controller:

- Nested interrupts with 3 software priority levels
- 26 interrupt vectors with hardware priority
- Up to 6 external interrupt sources on 6 vectors
- Trap and reset interrupts.

## 3.5 Memory

The STM8L001J3 devices have the following main features:

- 1.5 Kbytes of RAM
- The EEPROM is divided into two memory arrays (see the *STM8L001xx, STM8L101xx microcontroller family* reference manual (RM0013) for details on the memory mapping):
  - 8 Kbytes of low-density embedded Flash program including up to 2 Kbytes of data EEPROM. Data EEPROM and Flash program areas can be write protected independently by using the memory access security mechanism (MASS).
  - 64 option bytes (one block) of which 5 bytes are already used for the device.

Error correction code is implemented on the EEPROM.

### Recommendation for the device's programming:

The device's 8 Kbytes program memory is not empty on virgin devices; there is code loop implemented on the reset vector. It is recommended to keep valid code loop in the device to avoid the program execution from an invalid memory address (which would be any memory address out of 8 Kbytes program memory space).

If the device's program memory is empty (0x00 content), it displays the behavior described below:

- After the power on, the “empty” code is executed (0x0000 opcodes = instructions: NEG (0x00, SP)) until the device reaches the end of the 8 Kbytes program memory (the end address = 0x9FFF).  
It takes around 4 milliseconds to reach the end of the 8 Kbytes memory space @2 MHz HSI clock.
- Once the device reaches the end of the 8 Kbytes program memory, the program continues and code from a non-existing memory is fetched and executed.

The reading of non-existing memory is a random content which can lead to the execution of invalid instructions.

The execution of invalid instructions generates a software reset and the program starts again. A reset can be generated every 4 milliseconds or more.

Only the “connect on-the-fly” method can be used to program the device through the SWIM interface. The “connect under-reset” method cannot be used because the NRST pin is not available on this device.

The “connect on-the-fly” mode can be used while the device is executing code, but if there is a device reset (by software reset) during the SWIM connection, this connection is aborted and it must be performed again from the debug tool. Note that the software reset occurrence can be of every 4 milliseconds, making it difficult to successfully connect to the device's debug tool (there is practically only one successful connection trial for every 10 attempts). Once that a successful connection is reached, the device can be programmed with a valid firmware without problems; therefore it is recommended that device is never erased and that it contains always a valid code loop.

### 3.6 Low power modes

To minimize power consumption, the product features three low power modes:

- Wait mode: CPU clock stopped, selected peripherals at full clock speed.
- Active-halt mode: CPU and peripheral clocks are stopped. The programmable wakeup time is controlled by the AWU unit.
- Halt mode: CPU and peripheral clocks are stopped, the device remains powered on. The RAM content is preserved. Wakeup is triggered by an external interrupt.

### 3.7 Voltage regulators

The STM8L001J3 embeds an internal voltage regulator for generating the 1.8 V power supply for the core and peripherals.

This regulator has two different modes: main voltage regulator mode (MVR) and low power voltage regulator mode (LPVR). When entering Halt or Active-halt modes, the system automatically switches from the MVR to the LPVR in order to reduce current consumption.

### 3.8 Clock control

The STM8L001J3 embeds a robust clock controller. It is used to distribute the system clock to the core and the peripherals and to manage clock gating for low power modes. This system clock is a 16-MHz High Speed Internal RC oscillator (HSI RC), followed by a programmable prescaler.

In addition, a 38 kHz low speed internal RC oscillator is used by the independent watchdog (IWDG) and Auto-wakeup unit (AWU).

### 3.9 Independent watchdog

The independent watchdog (IWDG) peripheral can be used to resolve processor malfunctions due to hardware or software failures.

It is clocked by the 38 kHz LSI internal RC clock source, and thus stays active even in case of a CPU clock failure.

### 3.10 Auto-wakeup counter

The auto-wakeup (AWU) counter is used to wakeup the device from Active-halt mode.

### 3.11 General purpose and basic timers

STM8L001J3 devices contain two 16-bit general purpose timers (TIM2 and TIM3) and one 8-bit basic timer (TIM4).

### 16-bit general purpose timers

The 16-bit timers consist of 16-bit up/down auto-reload counters driven by a programmable prescaler. They perform a wide range of functions, including:

- Time base generation
- Measuring the pulse lengths of input signals (input capture)
- Generating output waveforms (output compare, PWM and One pulse mode)
- Interrupt capability on various events (capture, compare, overflow, break, trigger)

### 8-bit basic timer

The 8-bit timer consists of an 8-bit up auto-reload counter driven by a programmable prescaler. It can be used for timebase generation with interrupt generation on timer overflow.

## 3.12 Beeper

The STM8L001J3 devices include a beeper function used to generate a beep signal in the range of 1, 2 or 4 kHz when the LSI clock is operating at a frequency of 38 kHz.

## 3.13 Infrared (IR) interface

The STM8L001J3 devices contain an infrared interface which can be used with an IR LED for remote control functions. Two timer output compare channels are used to generate the infrared remote control signals.

## 3.14 Comparators

The STM8L001J3 features two zero-crossing comparators (COMP1 and COMP2) sharing the same current bias and voltage reference. The voltage reference can be internal (comparison with ground) or external (comparison to a reference pin voltage).

Each comparator is connected to 4 channels, which can be used to generate interrupt, timer input capture or timer break. Their polarity can be inverted.

## 3.15 USART

The USART interface (USART) allows full duplex, asynchronous communications with external devices requiring an industry standard NRZ asynchronous serial data format. It offers a very wide range of baud rates.

## 3.16 SPI

The serial peripheral interface (SPI) provides half/ full duplex synchronous serial communication with external devices. It can be configured as the master and in this case it provides the communication clock (SCK) to the external slave device. The interface can also operate in multi-master configuration.

### 3.17 I2C

The inter-integrated circuit (I2C) bus interface is designed to serve as an interface between the microcontroller and the serial I2Cbus. It provides multi-master capability, and controls all I2C bus-specific sequencing, protocol, arbitration and timing. It manages standard and fast speed modes.

# 4 Pin description

Figure 2. STM8L001J3 SO8N pinout

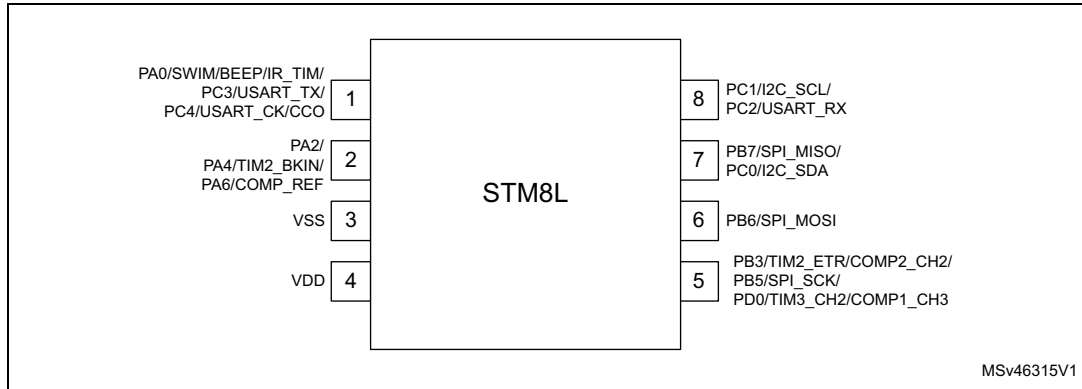

Table 2. Legend/abbreviation for table 4

<b>Type</b>	I= input, O = output, S = power supply	
<b>Level</b>	Input	CM = CMOS
	Output	HS = high sink/source (20 mA)
<b>Port and control configuration</b>	Input	float = floating, wpu = weak pull-up
	Output	T = true open drain, OD = open drain, PP = push pull
<b>Reset state</b>	Bold X (pin state after reset release). Unless otherwise specified, the pin state is the same during the reset phase (i.e. "under reset") and after internal reset release (i.e. at reset state).	

Table 3. STM8L001J3 pin description

Pin number	Pin name	Type	Input			Output			Main function (after reset)	Alternate function
			Floating	WPU	Ext. interrupt	High sink / source	OD	PP		
1	PA0 <sup>(1)</sup> /SWIM/BEEP/ IR_TIM <sup>(2)</sup>	I/O	X	X <sup>(1)</sup>	C	HS <sup>(2)</sup>	X	X	Port A0	SWIM input and output / Beep output/ Timer infrared output
	PC3/USART_TX	I/O	X <sup>(1)</sup>	X	X	HS	X	X	Port C3	USART transmit
	PC4/USART_CK/ CCO	I/O	X <sup>(1)</sup>	X	X	HS	X	X	Port C4	USART synchronous clock / Configurable clock output
2	PA2	I/O	X	X	X	HS	X	X	Port A2	-
	PA4/TIM2_BKIN	I/O	X	X	X	HS	X	X	Port A4	Timer 2 - break input
	PA6/COMP_REF	I/O	X	X	X	HS	X	X	Port A6	Comparator external reference
3	V <sub>SS</sub>	S	-	-	-	-	-	-	-	Ground
4	V <sub>DD</sub>	S	-	-	-	-	-	-	-	Power supply
5	PD0/TIM3_CH2/ COMP1_CH3	I/O	X	X	X	HS	X	X	Port D0	Timer 3 - Channel 2 / Comparator 1 - Channel 3
	PB3/TIM2_ETR/ COMP2_CH2	I/O	X	X	X	HS	X	X	Port B3	Timer 2 - trigger / Comparator 2 - Channel 2
	PB5/SPI_SCK	I/O	X	X	X	HS	X	X	Port B5	SPI clock
6	PB6/SPI_MOSI	I/O	X	X	X	HS	X	X	Port B6	SPI master out / slave in
7	PB7/SPI_MISO	I/O	X	X	X	HS	X	X	Port B7	SPI master in / slave out
	PC0/I2C_SDA	I/O	X	-	X	-	T <sup>(3)</sup>	-	Port C0	I2C data
8	PC1/I2C_SCL	I/O	X	-	X	-	T <sup>(3)</sup>	-	Port C1	I2C clock
	PC2/USART_RX	I/O	X	X	X	HS	X	X	Port C2	USART receive

1. The PA0 pin is in input pull-up during the reset phase and after internal reset release. This PA0 default state influences all the GPIOs connected in parallel on pin number 1 (PC3, PC4).
2. High sink LED driver capability available on PA0.
3. In the open-drain output column, 'T' defines a true open-drain I/O (P-buffer, weak pull-up and protection diode to  $V_{DD}$  are not implemented). Although PC0/PC1 itself is a true open drain GPIO with its respective internal circuitry and characteristics,  $V_{IN}$  maximum of the pin number 7 and pin number 8 is limited by the standard GPIO (PB7 or PC2) which is also bonded to the same pin number.

Slope control of all GPIO pins can be programmed except true open drain pins which by default is limited to 2 MHz.

*Note:* The PA1, PA3, PA5, PB0, PB1, PB2, PB4, PC5, PC6, PD1, PD2, PD3, PD4, PD5, PD6 and PD7 GPIOs should be configured after device reset, by user software into the in output push-pull mode with output-low state to reduce device consumption and to improve EMC immunity. Those GPIOs are not connected to pins and after device reset are in input floating mode. To configure PA1 pin in output push-pull mode refer to Section "Configuring NRST/PA1 pin as general purpose output" in the STM8L001xx, STM8L101xx microcontroller family reference manual (RM0013).

*Note:* As several pins provide a connection to multiple GPIOs, the mode selection for any of those GPIOs impacts all the other GPIOs connected to the same pin. The user is responsible for the proper setting of the GPIO modes in order to avoid conflicts between GPIOs bonded to the same pin (including their alternate functions). For example, pull-up enabled on PA0 is also seen on PC3 and PC4. Push-pull configuration of PA2 is also seen on PA4 and PA6, etc.



# 5 Memory and register map

Figure 3. Memory map

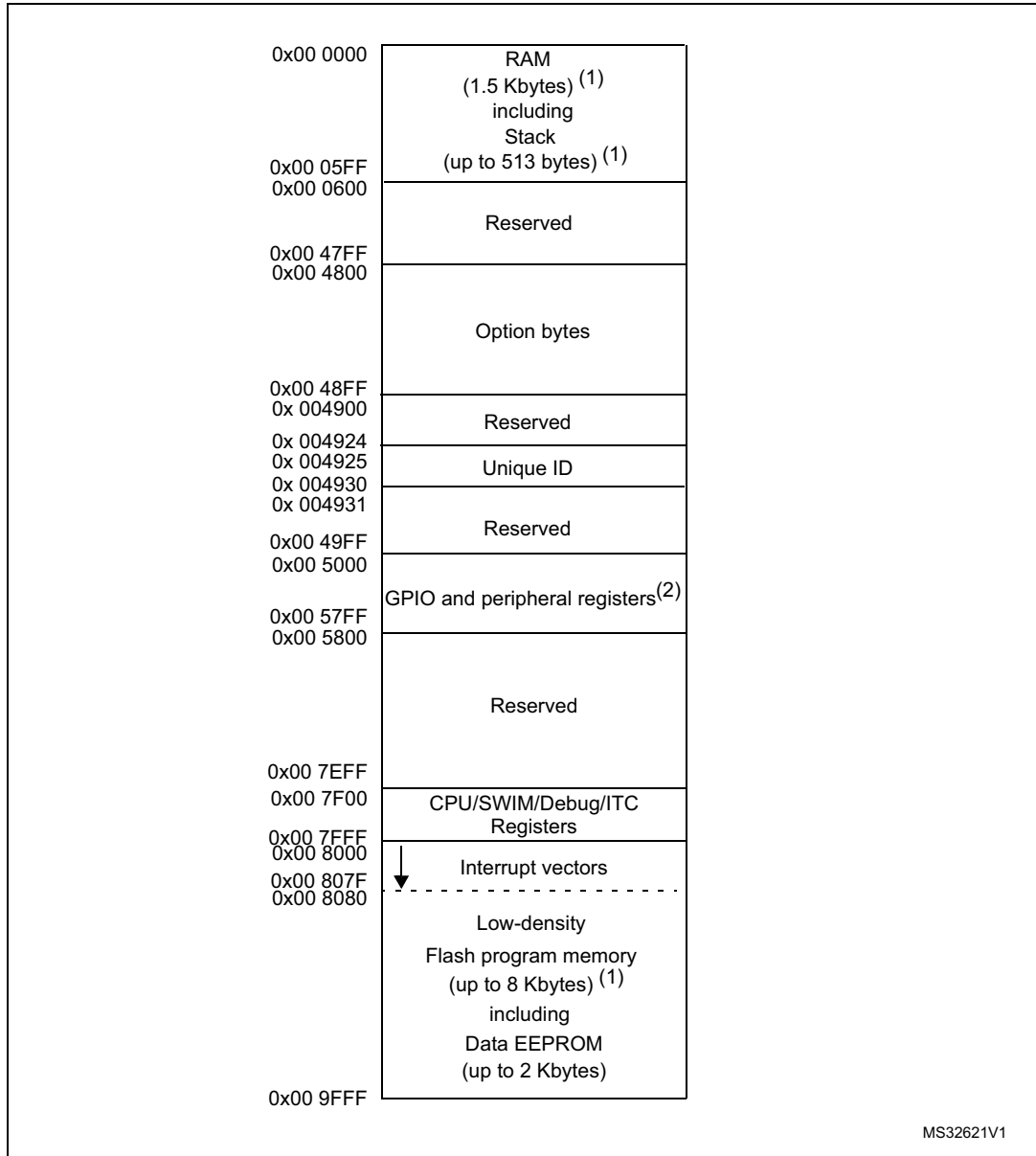

1. [Table 4](#) lists the boundary addresses for each memory size. The top of the stack is at the RAM end address.
2. Refer to [Table 6](#) for an overview of hardware register mapping, to [Table 5](#) for details on I/O port hardware registers, and to [Table 7](#) for information on CPU/SWIM/debug module controller registers.

Table 4. Flash and RAM boundary addresses

Memory area	Size	Start address	End address
RAM	1.5 Kbytes	0x00 0000	0x00 05FF
Flash program memory	8 Kbytes	0x00 8000	0x00 9FFF

Table 5. I/O Port hardware register map

Address	Block	Register label	Register name	Reset status
0x00 5000	Port A	PA_ODR	Port A data output latch register	0x00
0x00 5001		PA_IDR	Port A input pin value register	0xxx
0x00 5002		PA_DDR	Port A data direction register	0x00
0x00 5003		PA_CR1	Port A control register 1	0x00
0x00 5004		PA_CR2	Port A control register 2	0x00
0x00 5005	Port B	PB_ODR	Port B data output latch register	0x00
0x00 5006		PB_IDR	Port B input pin value register	0xxx
0x00 5007		PB_DDR	Port B data direction register	0x00
0x00 5008		PB_CR1	Port B control register 1	0x00
0x00 5009		PB_CR2	Port B control register 2	0x00
0x00 500A	Port C	PC_ODR	Port C data output latch register	0x00
0x00 500B		PC_IDR	Port C input pin value register	0xxx
0x00 500C		PC_DDR	Port C data direction register	0x00
0x00 500D		PC_CR1	Port C control register 1	0x00
0x00 500E		PC_CR2	Port C control register 2	0x00
0x00 500F	Port D	PD_ODR	Port D data output latch register	0x00
0x00 5010		PD_IDR	Port D input pin value register	0xxx
0x00 5011		PD_DDR	Port D data direction register	0x00
0x00 5012		PD_CR1	Port D control register 1	0x00
0x00 5013		PD_CR2	Port D control register 2	0x00

Table 6. General hardware register map

Address	Block	Register label	Register name	Reset status
0x00 5050	Flash	FLASH_CR1	Flash control register 1	0x00
0x00 5051		FLASH_CR2	Flash control register 2	0x00
0x00 5052		FLASH_PUKR	Flash Program memory unprotection register	0x00
0x00 5053		FLASH_DUKR	Data EEPROM unprotection register	0x00
0x00 5054		FLASH_IAPSR	Flash in-application programming status register	0xX0
0x00 5055 to 0x00 509F	Reserved area (75 bytes)			
0x00 50A0	ITC-EXTI	EXTI_CR1	External interrupt control register 1	0x00
0x00 50A1		EXTI_CR2	External interrupt control register 2	0x00
0x00 50A2		EXTI_CR3	External interrupt control register 3	0x00
0x00 50A3		EXTI_SR1	External interrupt status register 1	0x00
0x00 50A4		EXTI_SR2	External interrupt status register 2	0x00
0x00 50A5		EXTI_CONF	External interrupt port select register	0x00
0x00 50A6	WFE	WFE_CR1	WFE control register 1	0x00
0x00 50A7		WFE_CR2	WFE control register 2	0x00
0x00 50A8 to 0x00 50AF	Reserved area (8 bytes)			
0x00 50B0	RST	RST_CR	Reset control register	0x00
0x00 50B1		RST_SR	Reset status register	0x01
0x00 50B2 to 0x00 50BF	Reserved area (14 bytes)			
0x00 50C0	CLK	CLK_CKDIVR	Clock divider register	0x03
0x00 50C1 to 0x00 50C2		Reserved area (2 bytes)		
0x00 50C3		CLK_PCKENR	Peripheral clock gating register	0x00
0x00 50C4		Reserved (1 byte)		
0x00 50C5		CLK_CCOR	Configurable clock control register	0x00
0x00 50C6 to 0x00 50DF	Reserved area (25 bytes)			

Table 6. General hardware register map (continued)

Address	Block	Register label	Register name	Reset status	
0x00 50E0	IWDG	IWDG_KR	IWDG key register	0xXX	
0x00 50E1		IWDG_PR	IWDG prescaler register	0x00	
0x00 50E2		IWDG_RLR	IWDG reload register	0xFF	
0x00 50E3 to 0x00 50EF	Reserved area (13 bytes)				
0x00 50F0	AWU	AWU_CSR	AWU control/status register	0x00	
0x00 50F1		AWU_APR	AWU asynchronous prescaler buffer register	0x3F	
0x00 50F2		AWU_TBR	AWU timebase selection register	0x00	
0x00 50F3	BEEP	BEEP_CSR	BEEP control/status register	0x1F	
0x00 50F4 to 0x00 51FF	Reserved area (268 bytes)				
0x00 5200	SPI	SPI_CR1	SPI control register 1	0x00	
0x00 5201		SPI_CR2	SPI control register 2	0x00	
0x00 5202		SPI_ICR	SPI interrupt control register	0x00	
0x00 5203		SPI_SR	SPI status register	0x02	
0x00 5204		SPI_DR	SPI data register	0x00	
0x00 5205 to 0x00 520F	Reserved area (11 bytes)				
0x00 5210	I2C	I2C_CR1	I2C control register 1	0x00	
0x00 5211		I2C_CR2	I2C control register 2	0x00	
0x00 5212		I2C_FREQR	I2C frequency register	0x00	
0x00 5213		I2C_OARL	I2C own address register low	0x00	
0x00 5214		I2C_OARH	I2C own address register high	0x00	
0x00 5215		Reserved area (1 byte)			
0x00 5216		I2C_DR	I2C data register	0x00	
0x00 5217		I2C_SR1	I2C status register 1	0x00	
0x00 5218		I2C_SR2	I2C status register 2	0x00	
0x00 5219		I2C_SR3	I2C status register 3	0x00	
0x00 521A		I2C_ITR	I2C interrupt control register	0x00	
0x00 521B		I2C_CCRL	I2C Clock control register low	0x00	
0x00 521C		I2C_CCRH	I2C Clock control register high	0x00	
0x00 521D		I2C_TRISER	I2C TRISE register	0x02	

Table 6. General hardware register map (continued)

Address	Block	Register label	Register name	Reset status
0x00 521E to 0x00 522F	Reserved area (18 bytes)			
0x00 5230	USART	USART_SR	USART status register	0xC0
0x00 5231		USART_DR	USART data register	0xFF
0x00 5232		USART_BRR1	USART baud rate register 1	0x00
0x00 5233		USART_BRR2	USART baud rate register 2	0x00
0x00 5234		USART_CR1	USART control register 1	0x00
0x00 5235		USART_CR2	USART control register 2	0x00
0x00 5236		USART_CR3	USART control register 3	0x00
0x00 5237		USART_CR4	USART control register 4	0x00
0x00 5238 to 0x00 524F	Reserved area (18 bytes)			

Table 6. General hardware register map (continued)

Address	Block	Register label	Register name	Reset status	
0x00 5250	TIM2	TIM2_CR1	TIM2 control register 1	0x00	
0x00 5251		TIM2_CR2	TIM2 control register 2	0x00	
0x00 5252		TIM2_SMCR	TIM2 slave mode control register	0x00	
0x00 5253		TIM2_ETR	TIM2 external trigger register	0x00	
0x00 5254		TIM2_IER	TIM2 interrupt enable register	0x00	
0x00 5255		TIM2_SR1	TIM2 status register 1	0x00	
0x00 5256		TIM2_SR2	TIM2 status register 2	0x00	
0x00 5257		TIM2_EGR	TIM2 event generation register	0x00	
0x00 5258		TIM2_CCMR1	TIM2 capture/compare mode register 1	0x00	
0x00 5259		TIM2_CCMR2	TIM2 capture/compare mode register 2	0x00	
0x00 525A		TIM2_CCER1	TIM2 capture/compare enable register 1	0x00	
0x00 525B		TIM2_CNTRH	TIM2 counter high	0x00	
0x00 525C		TIM2_CNTRL	TIM2 counter low	0x00	
0x00 525D		TIM2_PSCR	TIM2 prescaler register	0x00	
0x00 525E		TIM2_ARRH	TIM2 auto-reload register high	0xFF	
0x00 525F		TIM2_ARRL	TIM2 auto-reload register low	0xFF	
0x00 5260		TIM2_CCR1H	TIM2 capture/compare register 1 high	0x00	
0x00 5261		TIM2_CCR1L	TIM2 capture/compare register 1 low	0x00	
0x00 5262		TIM2_CCR2H	TIM2 capture/compare register 2 high	0x00	
0x00 5263		TIM2_CCR2L	TIM2 capture/compare register 2 low	0x00	
0x00 5264		TIM2_BKR	TIM2 break register	0x00	
0x00 5265		TIM2_OISR	TIM2 output idle state register	0x00	
0x00 5266 to 0x00 527F		Reserved area (26 bytes)			

Table 6. General hardware register map (continued)

Address	Block	Register label	Register name	Reset status
0x00 5280	TIM3	TIM3_CR1	TIM3 control register 1	0x00
0x00 5281		TIM3_CR2	TIM3 control register 2	0x00
0x00 5282		TIM3_SMCR	TIM3 slave mode control register	0x00
0x00 5283		TIM3_ETR	TIM3 external trigger register	0x00
0x00 5284		TIM3_IER	TIM3 interrupt enable register	0x00
0x00 5285		TIM3_SR1	TIM3 status register 1	0x00
0x00 5286		TIM3_SR2	TIM3 status register 2	0x00
0x00 5287		TIM3_EGR	TIM3 event generation register	0x00
0x00 5288		TIM3_CCMR1	TIM3 capture/compare mode register 1	0x00
0x00 5289		TIM3_CCMR2	TIM3 capture/compare mode register 2	0x00
0x00 528A		TIM3_CCER1	TIM3 capture/compare enable register 1	0x00
0x00 528B		TIM3_CNTRH	TIM3 counter high	0x00
0x00 528C		TIM3_CNTRL	TIM3 counter low	0x00
0x00 528D		TIM3_PSCR	TIM3 prescaler register	0x00
0x00 528E		TIM3_ARRH	TIM3 auto-reload register high	0xFF
0x00 528F		TIM3_ARRL	TIM3 auto-reload register low	0xFF
0x00 5290		TIM3_CCR1H	TIM3 capture/compare register 1 high	0x00
0x00 5291		TIM3_CCR1L	TIM3 capture/compare register 1 low	0x00
0x00 5292		TIM3_CCR2H	TIM3 capture/compare register 2 high	0x00
0x00 5293		TIM3_CCR2L	TIM3 capture/compare register 2 low	0x00
0x00 5294		TIM3_BKR	TIM3 break register	0x00
0x00 5295		TIM3_OISR	TIM3 output idle state register	0x00
0x00 5296 to 0x00 52DF		Reserved area (74 bytes)		
0x00 52E0	TIM4	TIM4_CR1	TIM4 control register 1	0x00
0x00 52E1		TIM4_CR2	TIM4 control register 2	0x00
0x00 52E2		TIM4_SMCR	TIM4 Slave mode control register	0x00
0x00 52E3		TIM4_IER	TIM4 interrupt enable register	0x00
0x00 52E4		TIM4_SR1	TIM4 Status register 1	0x00
0x00 52E5		TIM4_EGR	TIM4 event generation register	0x00
0x00 52E6		TIM4_CNTR	TIM4 counter	0x00
0x00 52E7		TIM4_PSCR	TIM4 prescaler register	0x00
0x00 52E8		TIM4_ARR	TIM4 auto-reload register low	0xFF

Table 6. General hardware register map (continued)

Address	Block	Register label	Register name	Reset status
0x00 52E9 to 0x00 52FE	Reserved area (23 bytes)			
0x00 52FF	IRTIM	IR_CR	Infra-red control register	0x00
0x00 5300	COMP	COMP_CR	Comparator control register	0x00
0x00 5301		COMP_CSR	Comparator status register	0x00
0x00 5302		COMP_CCS	Comparator channel selection register	0x00

Table 7. CPU/SWIM/debug module/interrupt controller registers

Address	Block	Register label	Register name	Reset status
0x00 7F00	CPU	A	Accumulator	0x00
0x00 7F01		PCE	Program counter extended	0x00
0x00 7F02		PCH	Program counter high	0x80
0x00 7F03		PCL	Program counter low	0x00
0x00 7F04		XH	X index register high	0x00
0x00 7F05		XL	X index register low	0x00
0x00 7F06		YH	Y index register high	0x00
0x00 7F07		YL	Y index register low	0x00
0x00 7F08		SPH	Stack pointer high	0x05
0x00 7F09		SPL	Stack pointer low	0xFF
0x00 7F0A		CC	Condition code register	0x28
0x00 7F0B to 0x00 7F5F		Reserved area (85 bytes)		
0x00 7F60	CFG	CFG_GCR	Global configuration register	0x00
0x00 7F61 0x00 7F6F	Reserved area (15 bytes)			
0x00 7F70	ITC-SPR (1)	ITC_SPR1	Interrupt Software priority register 1	0xFF
0x00 7F71		ITC_SPR2	Interrupt Software priority register 2	0xFF
0x00 7F72		ITC_SPR3	Interrupt Software priority register 3	0xFF
0x00 7F73		ITC_SPR4	Interrupt Software priority register 4	0xFF
0x00 7F74		ITC_SPR5	Interrupt Software priority register 5	0xFF
0x00 7F75		ITC_SPR6	Interrupt Software priority register 6	0xFF
0x00 7F76		ITC_SPR7	Interrupt Software priority register 7	0xFF
0x00 7F77		ITC_SPR8	Interrupt Software priority register 8	0xFF



Table 7. CPU/SWIM/debug module/interrupt controller registers (continued)

Address	Block	Register label	Register name	Reset status
0x00 7F78 to 0x00 7F79	Reserved area (2 bytes)			
0x00 7F80	SWIM	SWIM_CSR	SWIM control status register	0x00
0x00 7F81 to 0x00 7F8F	Reserved area (15 bytes)			
0x00 7F90	DM	DM_BK1RE	Breakpoint 1 register extended byte	0xFF
0x00 7F91		DM_BK1RH	Breakpoint 1 register high byte	0xFF
0x00 7F92		DM_BK1RL	Breakpoint 1 register low byte	0xFF
0x00 7F93		DM_BK2RE	Breakpoint 2 register extended byte	0xFF
0x00 7F94		DM_BK2RH	Breakpoint 2 register high byte	0xFF
0x00 7F95		DM_BK2RL	Breakpoint 2 register low byte	0xFF
0x00 7F96		DM_CR1	Debug module control register 1	0x00
0x00 7F97		DM_CR2	Debug module control register 2	0x00
0x00 7F98		DM_CSR1	Debug module control/status register 1	0x10
0x00 7F99		DM_CSR2	Debug module control/status register 2	0x00
0x00 7F9A		DM_ENFCTR	Enable function register	0xFF

1. Refer to [Table 6: General hardware register map on page 19](#) (addresses 0x00 50A0 to 0x00 50A5) for a list of external interrupt registers.

## 6 Interrupt vector mapping

Table 8. Interrupt mapping

IRQ No.	Source block	Description	Wakeup from Halt mode	Wakeup from Active-halt mode	Wakeup from Wait (WFI mode)	Wakeup from Wait (WFE mode)	Vector address
-	RESET	Reset	Yes	Yes	Yes	Yes	0x00 8000
-	TRAP	Software interrupt	-	-	-	-	0x00 8004
0	-	Reserved	-	-	-	-	0x00 8008
1	FLASH	EOP/WR_PG_DIS	-	-	Yes	Yes <sup>(1)</sup>	0x00 800C
2-3	-	Reserved	-	-	-	-	0x00 8010 -0x00 8017
4	AWU	Auto wakeup from Halt	-	Yes	Yes	Yes <sup>(1)</sup>	0x00 8018
5	-	Reserved	-	-	-	-	0x00 801C
6	EXTIB	External interrupt port B	Yes	Yes	Yes	Yes	0x00 8020
7	EXTID	External interrupt port D	Yes	Yes	Yes	Yes	0x00 8024
8	EXTI0	External interrupt 0	Yes	Yes	Yes	Yes	0x00 8028
9	EXTI1	External interrupt 1	Yes	Yes	Yes	Yes	0x00 802C
10	EXTI2	External interrupt 2	Yes	Yes	Yes	Yes	0x00 8030
11	EXTI3	External interrupt 3	Yes	Yes	Yes	Yes	0x00 8034
12	EXTI4	External interrupt 4	Yes	Yes	Yes	Yes	0x00 8038
13	EXTI5	External interrupt 5	Yes	Yes	Yes	Yes	0x00 803C
14	EXTI6	External interrupt 6	Yes	Yes	Yes	Yes	0x00 8040
15	EXTI7	External interrupt 7	Yes	Yes	Yes	Yes	0x00 8044
16	-	Reserved	-	-	-	-	0x00 8048
17	-	Reserved	-	-	-	-	0x00 804C -0x00 804F
18	COMP	Comparators	-	-	Yes	Yes <sup>(1)</sup>	0x00 8050
19	TIM2	Update /Overflow/Trigger/Break	-	-	Yes	Yes	0x00 8054
20	TIM2	Capture/Compare	-	-	Yes	Yes	0x00 8058
21	TIM3	Update /Overflow/Break	-	-	Yes	Yes <sup>(1)</sup>	0x00 805C
22	TIM3	Capture/Compare	-	-	Yes	Yes <sup>(1)</sup>	0x00 8060
23-24	-	Reserved	-	-	-	-	0x00 8064- 0x00 806B
25	TIM4	Update /Trigger	-	-	Yes	Yes <sup>(1)</sup>	0x00 806C
26	SPI	End of Transfer	Yes	Yes	Yes	Yes <sup>(1)</sup>	0x00 8070

Table 8. Interrupt mapping (continued)

IRQ No.	Source block	Description	Wakeup from Halt mode	Wakeup from Active-halt mode	Wakeup from Wait (WFI mode)	Wakeup from Wait (WFE mode)	Vector address
27	USART	Transmission complete/transmit data register empty	-	-	Yes	Yes <sup>(1)</sup>	0x00 8074
28	USART	Receive Register DATA FULL/overrun/idle line detected/parity error	-	-	Yes	Yes <sup>(1)</sup>	0x00 8078
29	I2C	I2C interrupt <sup>(2)</sup>	Yes	Yes	Yes	Yes <sup>(1)</sup>	0x00 807C

1. In WFE mode, this interrupt is served if it has been previously enabled. After processing the interrupt, the processor goes back to WFE mode. Refer to Section *Wait for event (WFE) mode* in the *STM8L001xx, STM8L101xx microcontroller family* reference manual (RM0013).
2. The device is woken up from Halt or Active-halt mode only when the address received matches the interface address.

## 7 Option bytes

Option bytes contain configurations for device hardware features as well as the memory protection of the device. They are stored in a dedicated row of the memory.

All option bytes can be modified only in ICP mode (with SWIM) by accessing the EEPROM address. See [Table 9](#) for details on option byte addresses.

Refer to the *How to program STM8L and STM8AL Flash program memory and data EEPROM programming manual (PM0054)* and the *STM8 SWIM communication protocol and debug module user manual (UM0470)* for information on SWIM programming procedures.

**Table 9. Option bytes**

Addr.	Option name	Option byte No.	Option bits								Factory default setting
			7	6	5	4	3	2	1	0	
0x4800	Read-out protection (ROP)	OPT1	ROP[7:0]								0x00
0x4807	-	-	Reserved								0x00
0x4802	UBC (User Boot code size)	OPT2	UBC[7:0]								0x00
0x4803	DATASIZE	OPT3	DATASIZE[7:0]								0x00
0x4808	Independent watchdog option	OPT4 [1:0]	Reserved					IWDG _HALT	IWDG _HW	0x00	

**Table 10. Option byte description**

OPT1	<p><b>ROP[7:0] Memory readout protection (ROP)</b>            0xAA: Enable readout protection (write access via SWIM protocol)            Refer to <a href="#">Read-out protection</a> section in the <i>STM8L001xx, STM8L101xx microcontroller family reference manual (RM0013)</i> for details.</p>
OPT2	<p><b>UBC[7:0] Size of the user boot code area</b>            0x00: no UBC            0x01-0x02: UBC contains only the interrupt vectors.            0x03: Page 0 and 1 reserved for the interrupt vectors. Page 2 is available to store user boot code. Memory is write protected            ...            0x7F - Page 0 to 126 reserved for UBC, memory is write protected            Refer to <a href="#">User boot area (UBC)</a> section in the <i>STM8L001xx, STM8L101xx microcontroller family reference manual (RM0013)</i> for more details.            UBC[7] is forced to 0 internally by HW.</p>

Table 10. Option byte description (continued)

OPT3	<p><b>DATASIZE[7:0]</b> Size of the data EEPROM area</p> <p>0x00: no data EEPROM area</p> <p>0x01: 1 page reserved for data storage from 0x9FC0 to 0x9FFF</p> <p>0x02: 2 pages reserved for data storage from 0x9F80 to 0x9FFF</p> <p>...</p> <p>0x20: 32 pages reserved for data storage from 0x9800 to 0x9FFF</p> <p>Refer to <a href="#">Data EEPROM (DATA)</a> section in the <i>STM8L001xx, STM8L101xx microcontroller family</i> reference manual (RM0013) for more details.</p> <p>DATASIZE[7:6] are forced to 0 internal by HW.</p>
OPT4	<p><b>IWDG_HW:</b> <i>Independent watchdog</i></p> <p>0: Independent watchdog activated by software</p> <p>1: Independent watchdog activated by hardware</p>
	<p><b>IWDG_HALT:</b> <i>Independent window watchdog reset on Halt/Active-halt</i></p> <p>0: Independent watchdog continues running in Halt/Active-halt mode</p> <p>1: Independent watchdog stopped in Halt/Active-halt mode</p>

**Caution:** After a device reset, read access to the program memory is not guaranteed if address 0x4807 is not programmed to 0x00.

## 8 Electrical parameters

### 8.1 Parameter conditions

Unless otherwise specified, all voltages are referred to  $V_{SS}$ .

#### 8.1.1 Minimum and maximum values

Unless otherwise specified the minimum and maximum values are guaranteed in the worst conditions of ambient temperature, supply voltage and frequencies by tests in production on 100% of the devices with an ambient temperature at  $T_A = 25\text{ }^\circ\text{C}$  and  $T_A = T_A \text{ max}$  (given by the selected temperature range).

Data based on characterization results, design simulation and/or technology characteristics are indicated in the table footnotes and are not tested in production. Based on characterization, the minimum and maximum values refer to sample tests and represent the mean value plus or minus three times the standard deviation ( $\text{mean} \pm 3\sigma$ ).

#### 8.1.2 Typical values

Unless otherwise specified, typical data are based on  $T_A = 25\text{ }^\circ\text{C}$ ,  $V_{DD} = 3\text{ V}$ . They are given only as design guidelines and are not tested.

#### 8.1.3 Typical curves

Unless otherwise specified, all typical curves are given only as design guidelines and are not tested.

#### 8.1.4 Loading capacitor

The loading conditions used for pin parameter measurement are shown in [Figure 4](#).

**Figure 4. Pin loading conditions**

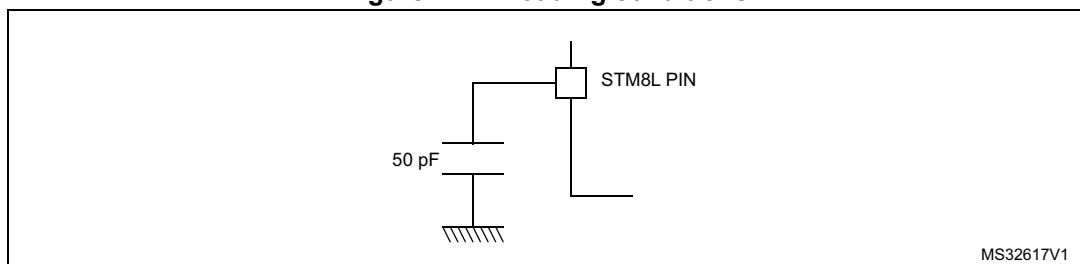

MS32617V1

### 8.1.5 Pin input voltage

The input voltage measurement on a pin of the device is described in [Figure 5](#).

Figure 5. Pin input voltage

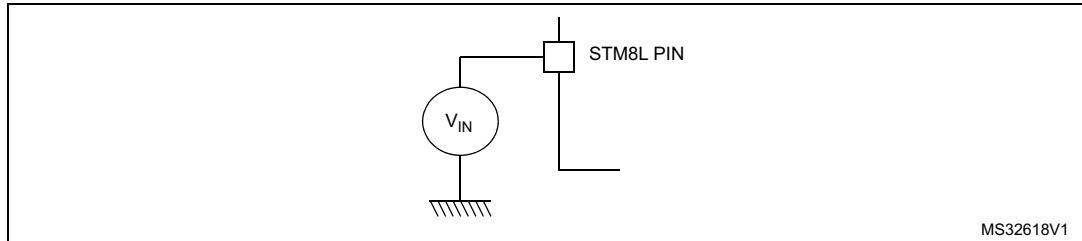

## 8.2 Absolute maximum ratings

Stresses above the absolute maximum ratings listed in [Table 11: Voltage characteristics](#), [Table 12: Current characteristics](#) and [Table 13: Thermal characteristics](#) may cause permanent damage to the device. These are stress ratings only and functional operation of the device at these conditions is not implied. Exposure to maximum rating conditions for extended periods may affect device reliability. The device mission profile is compliant with the JEDEC JESD47 qualification standard; extended mission profiles are available on demand.

Table 11. Voltage characteristics

Symbol	Ratings	Min	Max	Unit
$V_{DD} - V_{SS}$	External supply voltage	-0.3	4.0	V
$V_{IN}$	Input voltage on any pin <sup>(1)</sup>	$V_{SS} - 0.3$	$V_{DD} + 0.3$	
$V_{ESD}$	Electrostatic discharge voltage	see <a href="#">Absolute maximum ratings (electrical sensitivity) on page 52</a>		-

1.  $I_{INJ(PIN)}$  must never be exceeded. This is implicitly insured if  $V_{IN}$  maximum is respected. If  $V_{IN}$  maximum cannot be respected, the injection current must be limited externally to the  $I_{INJ(PIN)}$  value. A positive injection is induced by  $V_{IN} > V_{DD}$  while a negative injection is induced by  $V_{IN} < V_{SS}$ .

**Table 12. Current characteristics**

Symbol	Ratings	Max.	Unit
$I_{VDD}$	Total current into $V_{DD}$ power line (source)	80	mA
$I_{VSS}$	Total current out of $V_{SS}$ ground line (sink)	80	
$I_{IO}$	Output current sunk by IR_TIM pin (with high sink LED driver capability)	80	
	Output current sunk by any other I/O and control pin	25	
	Output current sourced by any I/Os and control pin	-25	
$I_{INJ(PIN)}$	Injected current on any pin <sup>(1)</sup>	±5	
$\Sigma I_{INJ(PIN)}$	Total injected current (sum of all I/O and control pins) <sup>(2)</sup>	±25	

- $I_{INJ(PIN)}$  must never be exceeded. This is implicitly insured if  $V_{IN}$  maximum is respected. If  $V_{IN}$  maximum cannot be respected, the injection current must be limited externally to the  $I_{INJ(PIN)}$  value. A positive injection is induced by  $V_{IN} > V_{DD}$  while a negative injection is induced by  $V_{IN} < V_{SS}$ .
- When several inputs are submitted to a current injection, the maximum  $\Sigma I_{INJ(PIN)}$  is the absolute sum of the positive and negative injected currents (instantaneous values). These results are based on characterization with  $\Sigma I_{INJ(PIN)}$  maximum current injection on four I/O port pins of the device.

**Table 13. Thermal characteristics**

Symbol	Ratings	Value	Unit
$T_{STG}$	Storage temperature range	-65 to +150	°C
$T_J$	Maximum junction temperature	150	



## 8.3 Operating conditions

Subject to general operating conditions for  $V_{DD}$  and  $T_A$ .

### 8.3.1 General operating conditions

Table 14. General operating conditions

Symbol	Parameter	Conditions	Min	Max	Unit
$f_{MASTER}^{(1)}$	Master clock frequency	$1.8\text{ V} \leq V_{DD} < 3.6\text{ V}$	0	16	MHz
$V_{DD}$	Standard operating voltage	-	1.8	3.6	V
$P_D^{(2)}$	Power dissipation at $T_A = 125\text{ °C}$ for suffix 3 devices	SO8N	-	49	mW
$T_A$	Temperature range	$1.8\text{ V} \leq V_{DD} < 3.6\text{ V}$ (3 suffix version)	-40	125	°C
$T_J$	Junction temperature range	$-40\text{ °C} \leq T_A \leq 125\text{ °C}$ (3 suffix version)	- 40	130	°C

1.  $f_{MASTER} = f_{CPU}$

2. To calculate  $P_{Dmax}(T_A)$  use the formula given in thermal characteristics  $P_{Dmax} = (T_{Jmax} - T_A) / \Theta_{JA}$  with  $T_{Jmax}$  in this table and  $\Theta_{JA}$  in table "Thermal characteristics"

### 8.3.2 Power-up / power-down operating conditions

Table 15. Operating conditions at power-up / power-down

Symbol	Parameter	Conditions	Min	Typ	Max	Unit
$t_{VDD}$	$V_{DD}$ rise time rate	-	20	-	1300	$\mu\text{s/V}$
$t_{TEMP}$	Reset release delay	$V_{DD}$ rising	-	1	-	ms
$V_{POR}^{(1)(2)}$	Power on reset threshold	-	1.35	-	1.65 <sup>(3)</sup>	V
$V_{PDR}^{(1)(2)}$	Power down reset threshold	-	1.40	-	1.60	V

1. Guaranteed by characterization results.
2. Correct device reset during power on sequence is guaranteed when  $t_{VDD[\text{max}]}$  is respected. External reset circuit is recommended to ensure correct device reset during power down, when  $V_{PDR} < V_{DD} < V_{DD[\text{min}]}$ .
3. Tested in production.

### 8.3.3 Supply current characteristics

#### Total current consumption

The MCU is placed under the following conditions:

- All I/O pins in input mode with a static value at  $V_{DD}$  or  $V_{SS}$  (no load)
- All peripherals are disabled except if explicitly mentioned.

Subject to general operating conditions for  $V_{DD}$  and  $T_A$ .

**Table 16. Total current consumption in Run mode <sup>(1)</sup>**

Symbol	Parameter	Conditions <sup>(2)</sup>		Typ	Max <sup>(3)</sup>	Unit
I <sub>DD (Run)</sub>	Supply current in Run mode <sup>(4) (5)</sup>	Code executed from RAM	f <sub>MASTER</sub> = 2 MHz	0.39	0.60	mA
			f <sub>MASTER</sub> = 4 MHz	0.55	0.70	
			f <sub>MASTER</sub> = 8 MHz	0.90	1.20	
			f <sub>MASTER</sub> = 16 MHz	1.60	2.10 <sup>(6)</sup>	
		Code executed from Flash	f <sub>MASTER</sub> = 2 MHz	0.55	0.70	
			f <sub>MASTER</sub> = 4 MHz	0.88	1.80	
			f <sub>MASTER</sub> = 8 MHz	1.50	2.50	
			f <sub>MASTER</sub> = 16 MHz	2.70	3.50	

1. Based on characterization results, unless otherwise specified.
2. All peripherals off, V<sub>DD</sub> from 1.8 V to 3.6 V, HSI internal RC osc., f<sub>CPU</sub>=f<sub>MASTER</sub>
3. Maximum values are given for T<sub>A</sub> = -40 to 125 °C.
4. CPU executing typical data processing.
5. An approximate value of I<sub>DD(Run)</sub> can be given by the following formula:  

$$I_{DD(Run)} = f_{MASTER} \times 150 \mu A/MHz + 215 \mu A.$$
6. Tested in production.

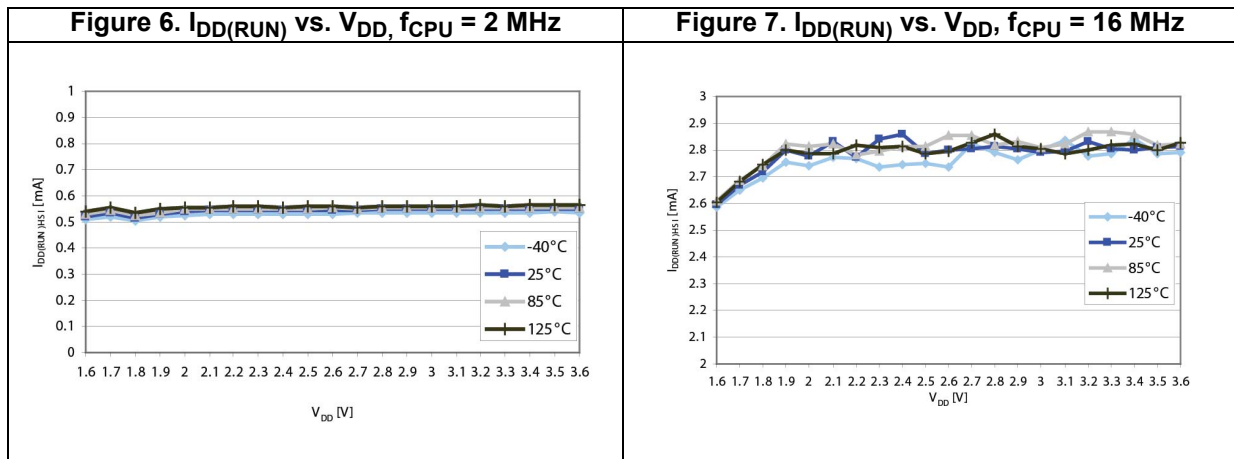

1. Typical current consumption measured with code executed from Flash.

Table 17. Total current consumption in Wait mode<sup>(1)</sup>

Symbol	Parameter	Conditions		Typ	Max <sup>(2)</sup>	Unit
I <sub>DD(Wait)</sub>	Supply current in Wait mode	CPU not clocked, all peripherals off, HSI internal RC osc.	f <sub>MASTER</sub> = 2 MHz	245	400	μA
			f <sub>MASTER</sub> = 4 MHz	300	450	
			f <sub>MASTER</sub> = 8 MHz	380	600	
			f <sub>MASTER</sub> = 16 MHz	510	800	

1. Based on characterization results, unless otherwise specified.
2. Maximum values are given for T<sub>A</sub> = -40 to 125 °C.

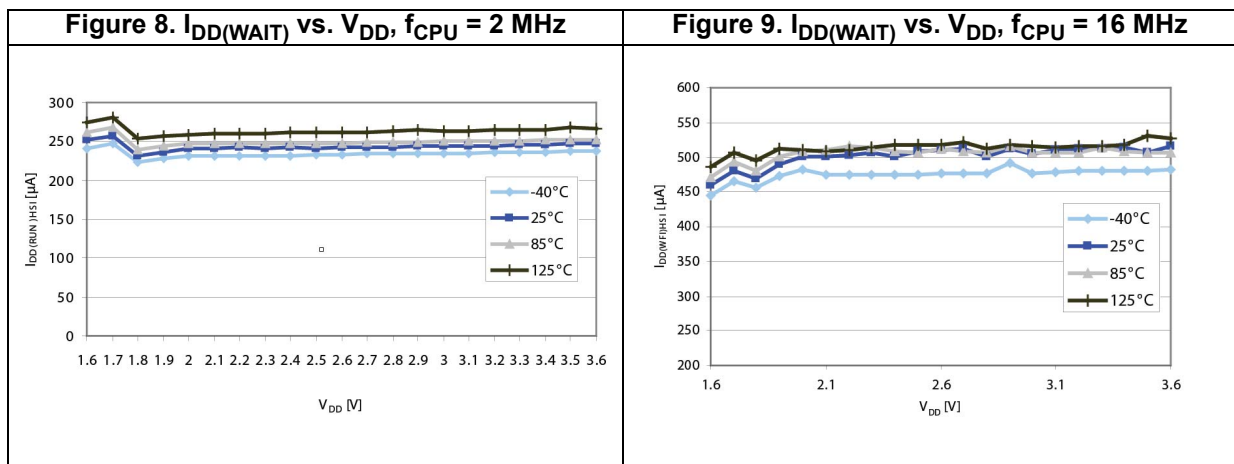

1. Typical current consumption measured with code executed from Flash.

**Table 18. Total current consumption and timing in Halt and Active-halt mode at  $V_{DD} = 1.8 \text{ V to } 3.6 \text{ V}^{(1)(2)}$**

Symbol	Parameter	Conditions	Typ	Max	Unit	
$I_{DD(AH)}$	Supply current in Active-halt mode	LSI RC osc. (at 37 kHz)	$T_A = -40 \text{ }^\circ\text{C to } 25 \text{ }^\circ\text{C}$	0.8	2	$\mu\text{A}$
			$T_A = 55 \text{ }^\circ\text{C}$	1	2.5	$\mu\text{A}$
			$T_A = 85 \text{ }^\circ\text{C}$	1.4	3.2	$\mu\text{A}$
			$T_A = 105 \text{ }^\circ\text{C}$	2.9	7.5	$\mu\text{A}$
			$T_A = 125 \text{ }^\circ\text{C}$	5.8	13	$\mu\text{A}$
$I_{DD(WUFAH)}$	Supply current during wakeup time from Active-halt mode	-	-	2	-	mA
$t_{WU(AH)}^{(3)}$	Wakeup time from Active-halt mode to Run mode	$f_{CPU} = 16 \text{ MHz}$	4	6.5	$\mu\text{s}$	
$I_{DD(Halt)}$	Supply current in Halt mode	$T_A = -40 \text{ }^\circ\text{C to } 25 \text{ }^\circ\text{C}$	0.35	1.2 <sup>(4)</sup>	$\mu\text{A}$	
		$T_A = 55 \text{ }^\circ\text{C}$	0.6	1.8	$\mu\text{A}$	
		$T_A = 85 \text{ }^\circ\text{C}$	1	2.5 <sup>(4)</sup>	$\mu\text{A}$	
		$T_A = 105 \text{ }^\circ\text{C}$	2.5	6.5	$\mu\text{A}$	
		$T_A = 125 \text{ }^\circ\text{C}$	5.4	12 <sup>(4)</sup>	$\mu\text{A}$	
$I_{DD(WUFH)}$	Supply current during wakeup time from Halt mode	-	-	2	-	mA
$t_{WU(Halt)}^{(3)}$	Wakeup time from Halt mode to Run mode	$f_{CPU} = 16 \text{ MHz}$	4	6.5	$\mu\text{s}$	

- $T_A = -40$  to  $125 \text{ }^\circ\text{C}$ , no floating I/O, unless otherwise specified.
- Guaranteed by characterization results.
- Measured from interrupt event to interrupt vector fetch.  
To get  $t_{WU}$  for another CPU frequency use  $t_{WU}(FREQ) = t_{WU}(16 \text{ MHz}) + 1.5 (T_{FREQ} - T_{16 \text{ MHz}})$ .  
The first word of interrupt routine is fetched 5 CPU cycles after  $t_{WU}$ .
- Tested in production.

**Figure 10. Typ.  $I_{DD(Halt)}$  vs.  $V_{DD}$ ,  $f_{CPU} = 2 \text{ MHz}$  and  $16 \text{ MHz}$**

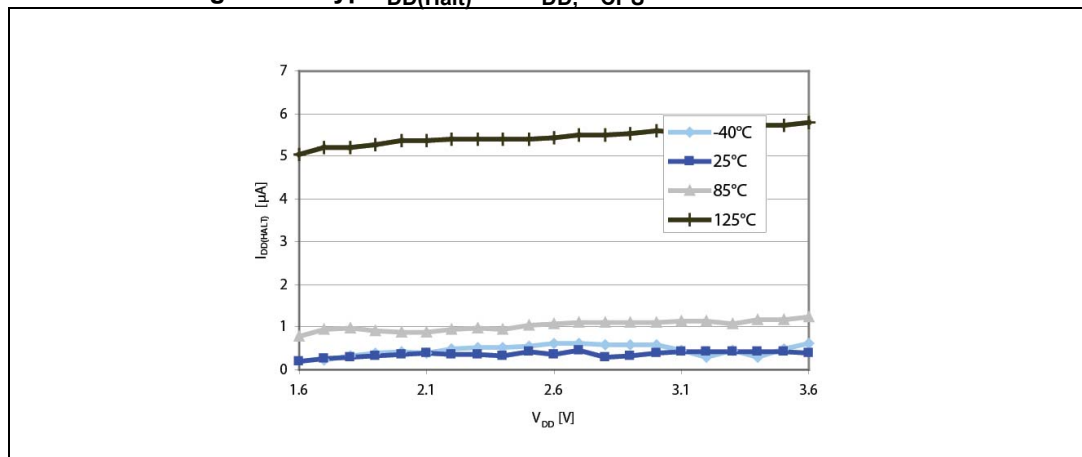

- Typical current consumption measured with code executed from Flash.

**Current consumption of on-chip peripherals**

Measurement made for  $f_{MASTER}$  = from 2 MHz to 16 MHz

**Table 19. Peripheral current consumption**

Symbol	Parameter	Typ. $V_{DD} = 3.0 V$	Unit
$I_{DD(TIM2)}$	TIM2 supply current <sup>(1)</sup>	9	μA/MHz
$I_{DD(TIM3)}$	TIM3 supply current <sup>(1)</sup>	9	
$I_{DD(TIM4)}$	TIM4 timer supply current <sup>(1)</sup>	4	
$I_{DD(USART)}$	USART supply current <sup>(2)</sup>	7	
$I_{DD(SPI)}$	SPI supply current <sup>(2)</sup>	4	
$I_{DD(I2C1)}$	I2C supply current <sup>(2)</sup>	4	
$I_{DD(COMP)}$	Comparator supply current <sup>(2)</sup>	20	μA

1. Data based on a differential  $I_{DD}$  measurement between all peripherals off and a timer counter running at 16 MHz. The CPU is in Wait mode in both cases. No IC/OC programmed, no I/O pin toggling. not tested in production.
2. Data based on a differential  $I_{DD}$  measurement between the on-chip peripheral when kept under reset and not clocked and the on-chip peripheral when clocked and not kept under reset. The CPU is in Wait mode in both cases. No I/O pin toggling. Not tested in production.

**8.3.4 Clock and timing characteristics**

**Internal clock sources**

Subject to general operating conditions for  $V_{DD}$  and  $T_A$ .

**High speed internal RC oscillator (HSI)**

**Table 20. HSI oscillator characteristics <sup>(1)</sup>**

Symbol	Parameter	Conditions	Min	Typ	Max	Unit
$f_{HSI}$	Frequency	$V_{DD} = 3.0 V$	-	16	-	MHz
$ACC_{HSI}$	Accuracy of HSI oscillator (factory calibrated)	$V_{DD} = 3.0 V, T_A = 25 ^\circ C$	-2.5	-	2.5	%
		$1.8 V \leq V_{DD} \leq 3.6 V, -40 ^\circ C \leq T_A \leq 125 ^\circ C$	-5 <sup>(2)</sup>	-	5 <sup>(2)</sup>	%
$I_{DD(HSI)}$	HSI oscillator power consumption	-	-	70	100 <sup>(2)</sup>	μA

1.  $V_{DD} = 3.0 V, T_A = -40$  to  $125 ^\circ C$  unless otherwise specified.
2. Guaranteed by characterization results.

Figure 11. Typical HSI frequency vs.  $V_{DD}$

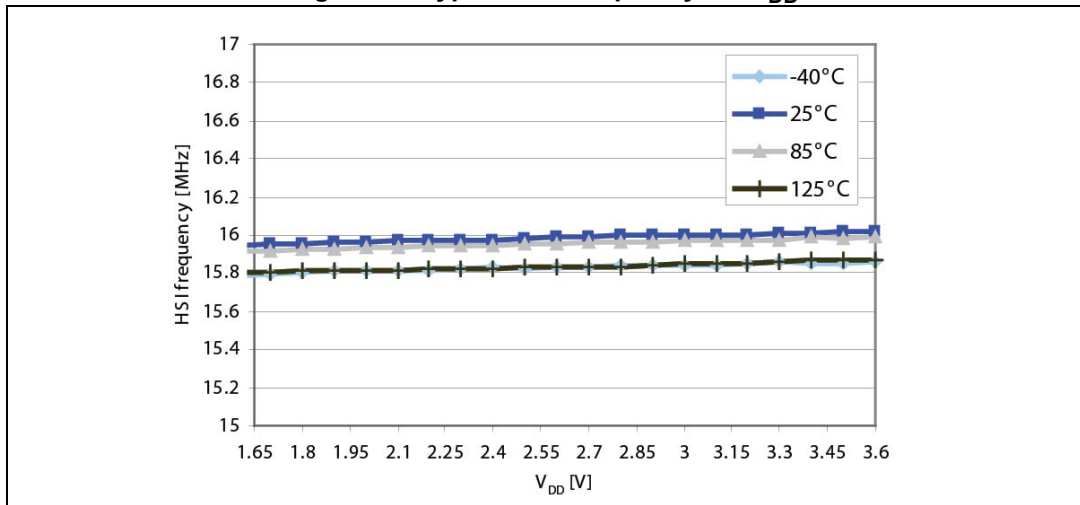

Figure 12. Typical HSI accuracy vs. temperature,  $V_{DD} = 3\text{ V}$

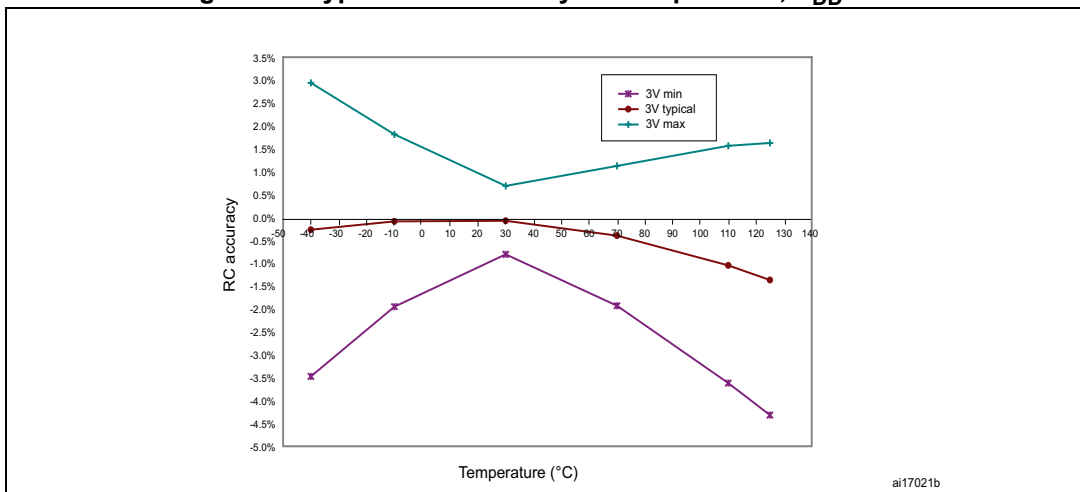
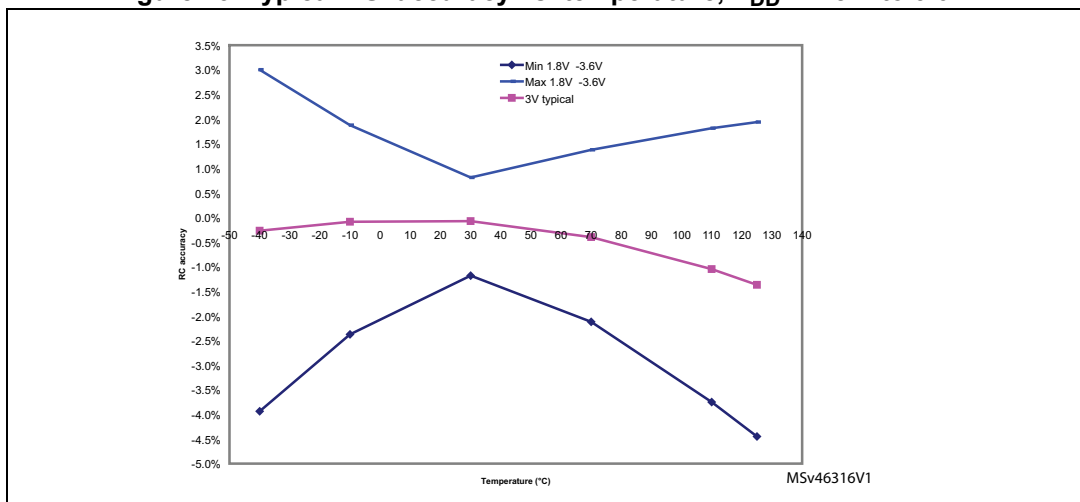

Figure 13. Typical HSI accuracy vs. temperature,  $V_{DD} = 1.8\text{ V to }3.6\text{ V}$



Low speed internal RC oscillator (LSI)

Table 21. LSI oscillator characteristics (1)

Symbol	Parameter	Conditions	Min	Typ	Max	Unit
$f_{LSI}$	Frequency	-	26	38	56	kHz
$f_{drift(LSI)}$	LSI oscillator frequency drift(2)	$0\text{ }^{\circ}\text{C} \leq T_A \leq 85\text{ }^{\circ}\text{C}$	-12	-	11	%

- $V_{DD} = 1.8\text{ V to }3.6\text{ V}$ ,  $T_A = -40\text{ to }125\text{ }^{\circ}\text{C}$  unless otherwise specified.
- For each individual part, this value is the frequency drift from the initial measured frequency.

Figure 14. Typical LSI RC frequency vs.  $V_{DD}$

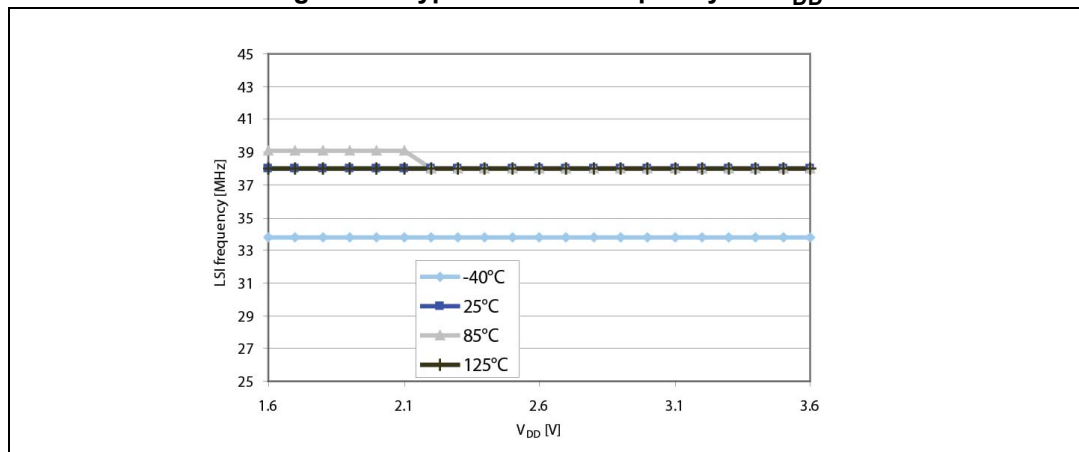

8.3.5 Memory characteristics

$T_A = -40\text{ to }125\text{ }^{\circ}\text{C}$  unless otherwise specified.

Table 22. RAM and hardware registers

Symbol	Parameter	Conditions	Min	Typ	Max	Unit
$V_{RM}$	Data retention mode (1)	Halt mode (or Reset)	1.65	-	-	V

- Minimum supply voltage without losing data stored in RAM (in Halt mode or under Reset) or in hardware registers (only in Halt mode). Guaranteed by characterization results.

Flash memory

Table 23. Flash program memory

Symbol	Parameter	Conditions	Min	Typ	Max (1)	Unit
$V_{DD}$	Operating voltage (all modes, read/write/erase)	$f_{MASTER} = 16\text{ MHz}$	1.8	-	3.6	V
$t_{prog}$	Programming time for 1- or 64-byte (block) erase/write cycles (on programmed byte)	-	-	6	-	ms
	Programming time for 1- to 64-byte (block) write cycles (on erased byte)	-	-	3	-	ms



Table 23. Flash program memory (continued)

Symbol	Parameter	Conditions	Min	Typ	Max (1)	Unit
$I_{prog}$	Programming/ erasing consumption	$T_A=+25\text{ }^\circ\text{C}$ , $V_{DD} = 3.0\text{ V}$	-	0.7	-	mA
		$T_A=+25\text{ }^\circ\text{C}$ , $V_{DD} = 1.8\text{ V}$	-		-	
$t_{RET}$	Data retention (program memory) after 10k erase/write cycles at $T_A = +85\text{ }^\circ\text{C}$	$T_{RET} = 55\text{ }^\circ\text{C}$	20 <sup>(1)</sup>	-	-	years
	Data retention (data memory) after 10k erase/write cycles at $T_A = +85\text{ }^\circ\text{C}$	$T_{RET} = 55\text{ }^\circ\text{C}$	20 <sup>(1)</sup>	-	-	
	Data retention (data memory) after 300k erase/write cycles at $T_A = +125\text{ }^\circ\text{C}$	$T_{RET} = 85\text{ }^\circ\text{C}$	1 <sup>(1)</sup>	-	-	
$N_{RW}$	Erase/write cycles (program memory)	See notes <sup>(1)(2)</sup>	100 <sup>(1)</sup>	-	-	cycles
	Erase/write cycles (data memory)	See notes <sup>(1)(3)</sup>	100 <sup>(1)(4)</sup>	-	-	kcycles

1. Guaranteed by characterization results.
2. Retention guaranteed after cycling is 10 years at 55 °C.
3. Retention guaranteed after cycling is 1 year at 55 °C.
4. Data based on characterization performed on the whole data memory (2 Kbytes).

### 8.3.6 I/O port pin characteristics

#### General characteristics

Subject to general operating conditions for  $V_{DD}$  and  $T_A$  unless otherwise specified. All unused pins must be kept at a fixed voltage: using the output mode of the I/O for example or an external pull-up or pull-down resistor.

Table 24. I/O static characteristics <sup>(1)</sup>

Symbol	Parameter	Conditions	Min	Typ	Max	Unit
$V_{IL}$	Input low level voltage <sup>(2)</sup>	All I/Os	$V_{SS}-0.3$	-	$0.3 \times V_{DD}$	V
$V_{IH}$	Input high level voltage <sup>(2)</sup>	All I/Os	$0.70 \times V_{DD}$	-	$V_{DD}+0.3$	V
$V_{hys}$	Schmitt trigger voltage hysteresis <sup>(3)</sup>	Standard I/Os	-	200	-	mV
		True open drain I/Os	-	250	-	
$I_{lkg}$	Input leakage current <sup>(4)</sup>	$V_{SS} \leq V_{IN} \leq V_{DD}$ Standard I/Os	-	-	50 <sup>(5)</sup>	nA
		$V_{SS} \leq V_{IN} \leq V_{DD}$ True open drain I/Os	-	-	200 <sup>(5)</sup>	
		$V_{SS} \leq V_{IN} \leq V_{DD}$ PA0 with high sink LED driver capability	-	-	200 <sup>(5)</sup>	
$R_{PU}$	Weak pull-up equivalent resistor <sup>(6)</sup>	$V_{IN} = V_{SS}$	30	45	60	k $\Omega$
$C_{IO}$ <sup>(7)</sup>	I/O pin capacitance	-	-	5 <sup>(8)</sup>	-	pF

1.  $V_{DD} = 3.0\text{ V}$ ,  $T_A = -40\text{ to }85\text{ }^\circ\text{C}$  unless otherwise specified.
2. Guaranteed by characterization results.
3. Hysteresis voltage between Schmitt trigger switching levels. Guaranteed by characterization results.
4. The max. value may be exceeded if negative current is injected on adjacent pins.
5. Not tested in production.
6.  $R_{PU}$  pull-up equivalent resistor based on a resistive transistor (corresponding  $I_{PU}$  current characteristics described in [Figure 17](#)).
7. Guaranteed by design.
8. Capacitance per one GPIO on pin. Complete pin capacitance depends on how many GPIOs are connected on a given pin (see [Table 3](#)). Total pin capacitance is then  $N \times C_{IO}$  (where  $N$  = number of GPIOs on a given pin).

Figure 15. Typical  $V_{IL}$  and  $V_{IH}$  vs.  $V_{DD}$  (High sink I/Os)

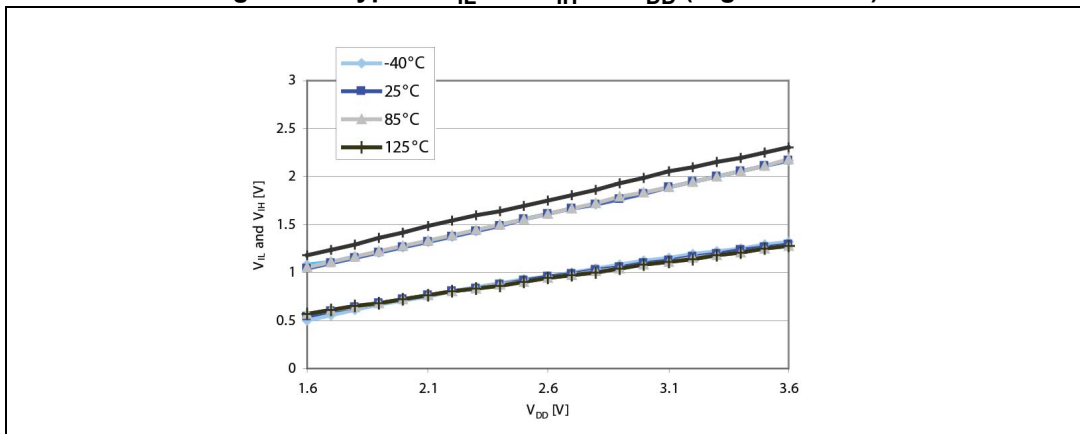

Figure 16. Typical  $V_{IL}$  and  $V_{IH}$  vs.  $V_{DD}$  (true open drain I/Os)

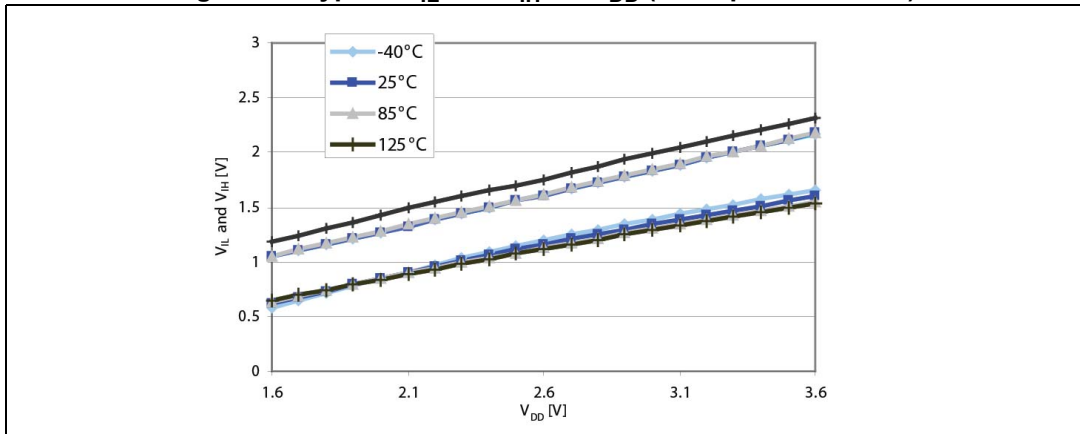

Figure 17. Typical pull-up resistance  $R_{PU}$  vs.  $V_{DD}$  with  $V_{IN}=V_{SS}$

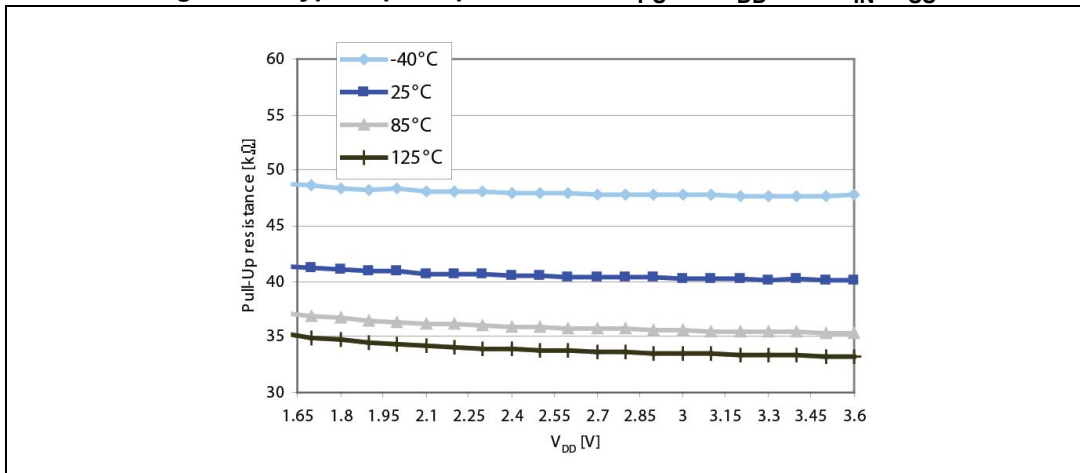
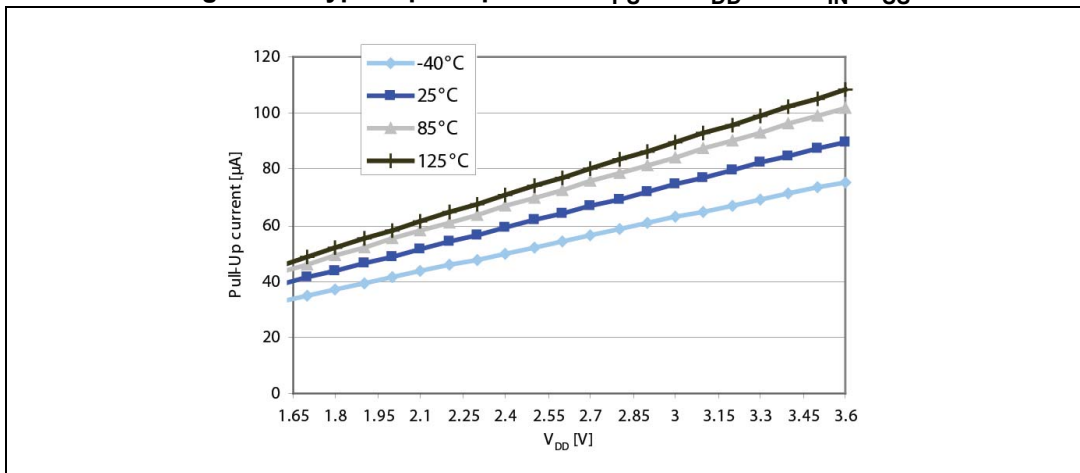

Figure 18. Typical pull-up current  $I_{PU}$  vs.  $V_{DD}$  with  $V_{IN}=V_{SS}$



**Output driving current**

Subject to general operating conditions for  $V_{DD}$  and  $T_A$  unless otherwise specified.

**Table 25. Output driving current (High sink ports)**

I/O Type	Symbol	Parameter	Conditions	Min	Max	Unit
Standard	$V_{OL}^{(1)}$	Output low level voltage for an I/O pin	$I_{IO} = +2 \text{ mA}$ , $V_{DD} = 3.0 \text{ V}$	-	0.45	V
			$I_{IO} = +2 \text{ mA}$ , $V_{DD} = 1.8 \text{ V}$	-	0.45	V
			$I_{IO} = +10 \text{ mA}$ , $V_{DD} = 3.0 \text{ V}$	-	1.2	V
	$V_{OH}^{(2)}$	Output high level voltage for an I/O pin	$I_{IO} = -2 \text{ mA}$ , $V_{DD} = 3.0 \text{ V}$	$V_{DD}-0.45$	-	V
			$I_{IO} = -1 \text{ mA}$ , $V_{DD} = 1.8 \text{ V}$	$V_{DD}-0.45$	-	V
			$I_{IO} = -10 \text{ mA}$ , $V_{DD} = 3.0 \text{ V}$	$V_{DD}-1.2$	-	V

1. The  $I_{IO}$  current sunk must always respect the absolute maximum rating specified in [Table 12](#) and the sum of  $I_{IO}$  (I/O ports and control pins) must not exceed  $I_{VSS}$ .
2. The  $I_{IO}$  current sourced must always respect the absolute maximum rating specified in [Table 12](#) and the sum of  $I_{IO}$  (I/O ports and control pins) must not exceed  $I_{VDD}$ .

**Table 26. Output driving current (true open drain ports)**

I/O Type	Symbol	Parameter	Conditions	Min	Max	Unit
Open drain	$V_{OL}^{(1)}$	Output low level voltage for an I/O pin	$I_{IO} = +3 \text{ mA}$ , $V_{DD} = 3.0 \text{ V}$	-	0.45	V
			$I_{IO} = +1 \text{ mA}$ , $V_{DD} = 1.8 \text{ V}$	-	0.45	V

1. The  $I_{IO}$  current sunk must always respect the absolute maximum rating specified in [Table 12](#) and the sum of  $I_{IO}$  (I/O ports and control pins) must not exceed  $I_{VSS}$ .

**Table 27. Output driving current (PA0 with high sink LED driver capability)**

I/O Type	Symbol	Parameter	Conditions	Min	Max	Unit
$\overline{R}$	$V_{OL}^{(1)}$	Output low level voltage for an I/O pin	$I_{IO} = +20 \text{ mA}$ , $V_{DD} = 2.0 \text{ V}$	-	0.9	V

1. The  $I_{IO}$  current sunk must always respect the absolute maximum rating specified in [Table 12](#) and the sum of  $I_{IO}$  (I/O ports and control pins) must not exceed  $I_{VSS}$ .

Figure 19. Typ.  $V_{OL}$  at  $V_{DD} = 3.0\text{ V}$  (High sink ports)

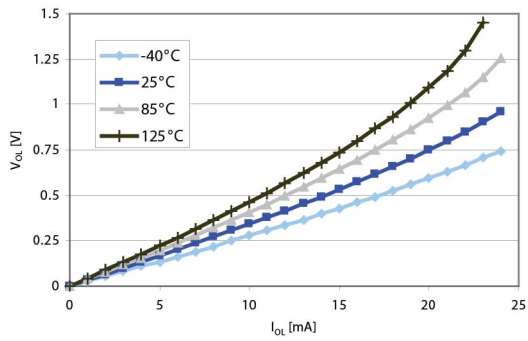

Figure 20. Typ.  $V_{OL}$  at  $V_{DD} = 1.8\text{ V}$  (High sink ports)

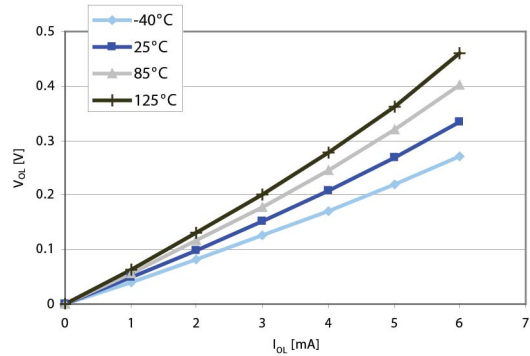

Figure 21. Typ.  $V_{OL}$  at  $V_{DD} = 3.0\text{ V}$  (true open drain ports)

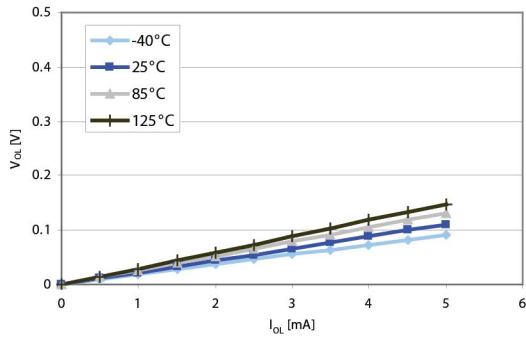

Figure 22. Typ.  $V_{OL}$  at  $V_{DD} = 1.8\text{ V}$  (true open drain ports)

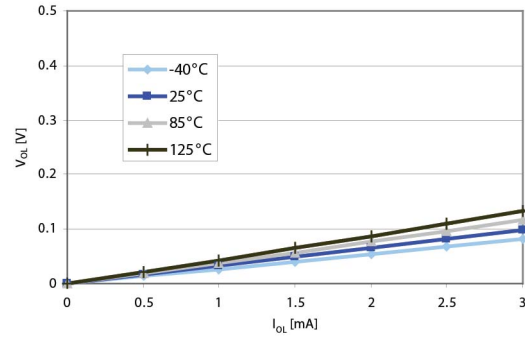

Figure 23. Typ.  $V_{DD} - V_{OH}$  at  $V_{DD} = 3.0\text{ V}$  (High sink ports)

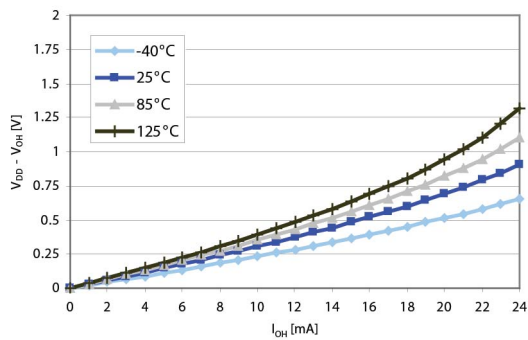
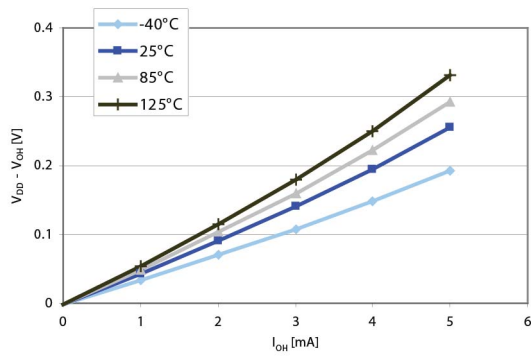

Figure 24. Typ.  $V_{DD} - V_{OH}$  at  $V_{DD} = 1.8\text{ V}$  (High sink ports)



### 8.3.7 Communication interfaces

#### Serial peripheral interface (SPI)

Unless otherwise specified, the parameters given in [Table 28](#) are derived from tests performed under ambient temperature,  $f_{MASTER}$  frequency and  $V_{DD}$  supply voltage conditions summarized in [Section 8.3.1](#). Refer to I/O port characteristics for more details on the input/output alternate function characteristics (NSS, SCK, MOSI, MISO).

**Table 28. SPI characteristics**

Symbol	Parameter	Conditions <sup>(1)</sup>	Min	Max	Unit
$f_{SCK}$ 1/ $t_{c(SCK)}$	SPI clock frequency	Master mode	0	8	MHz
		Slave mode	0	8	
$t_{r(SCK)}$ $t_{f(SCK)}$	SPI clock rise and fall time	Capacitive load: C = 30 pF	-	30	ns
$t_{su(NSS)}^{(2)}$	NSS setup time	Slave mode	$4 \times T_{MASTER}$	-	
$t_{h(NSS)}^{(2)}$	NSS hold time	Slave mode	80	-	
$t_{w(SCKH)}^{(2)}$ $t_{w(SCKL)}^{(2)}$	SCK high and low time	Master mode, $f_{MASTER} = 8 \text{ MHz}, f_{SCK} = 4 \text{ MHz}$	105	145	
$t_{su(MI)}^{(2)}$ $t_{su(SI)}^{(2)}$	Data input setup time	Master mode	30	-	
		Slave mode	3	-	
$t_{h(MI)}^{(2)}$ $t_{h(SI)}^{(2)}$	Data input hold time	Master mode	15	-	
		Slave mode	0	-	
$t_{a(SO)}^{(2)(3)}$	Data output access time	Slave mode	-	$3 \times T_{MASTER}$	
$t_{dis(SO)}^{(2)(4)}$	Data output disable time	Slave mode	30	-	
$t_{v(SO)}^{(2)}$	Data output valid time	Slave mode (after enable edge)	-	60	
$t_{v(MO)}^{(2)}$	Data output valid time	Master mode (after enable edge)	-	20	
$t_{h(SO)}^{(2)}$	Data output hold time	Slave mode (after enable edge)	15	-	
$t_{h(MO)}^{(2)}$		Master mode (after enable edge)	1	-	

- Parameters are given by selecting 10-MHz I/O output frequency.
- Values based on design simulation and/or characterization results, and not tested in production.
- Min time is for the minimum time to drive the output and max time is for the maximum time to validate the data.
- Min time is for the minimum time to invalidate the output and max time is for the maximum time to put the data in Hi-Z.

Figure 25. SPI timing diagram - slave mode and CPHA = 0

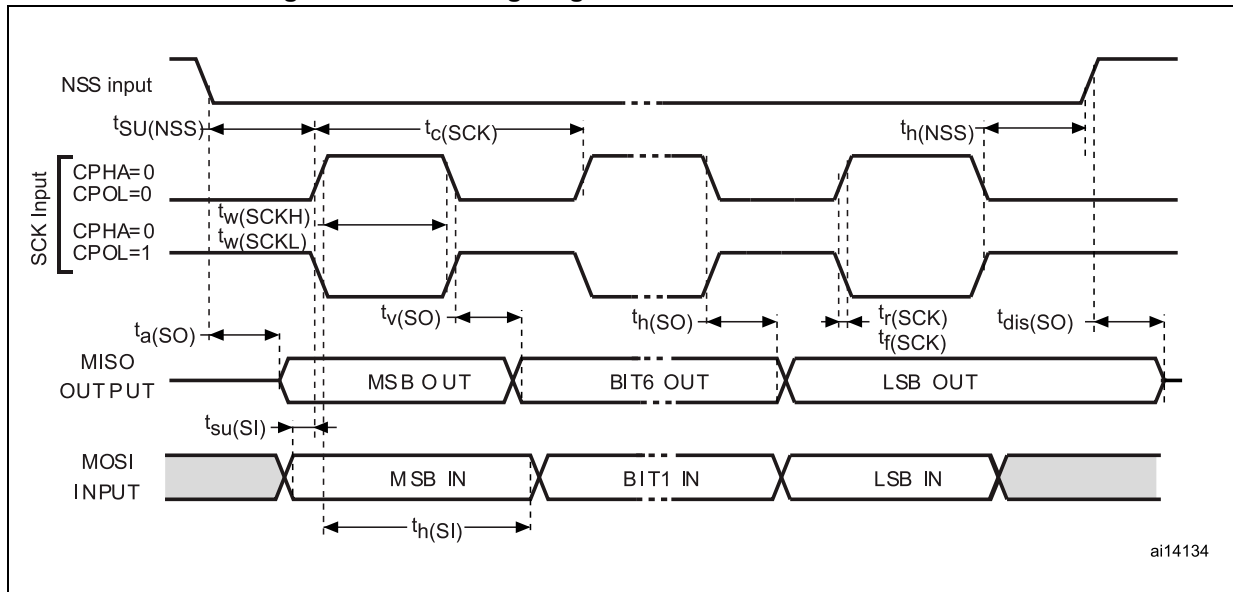
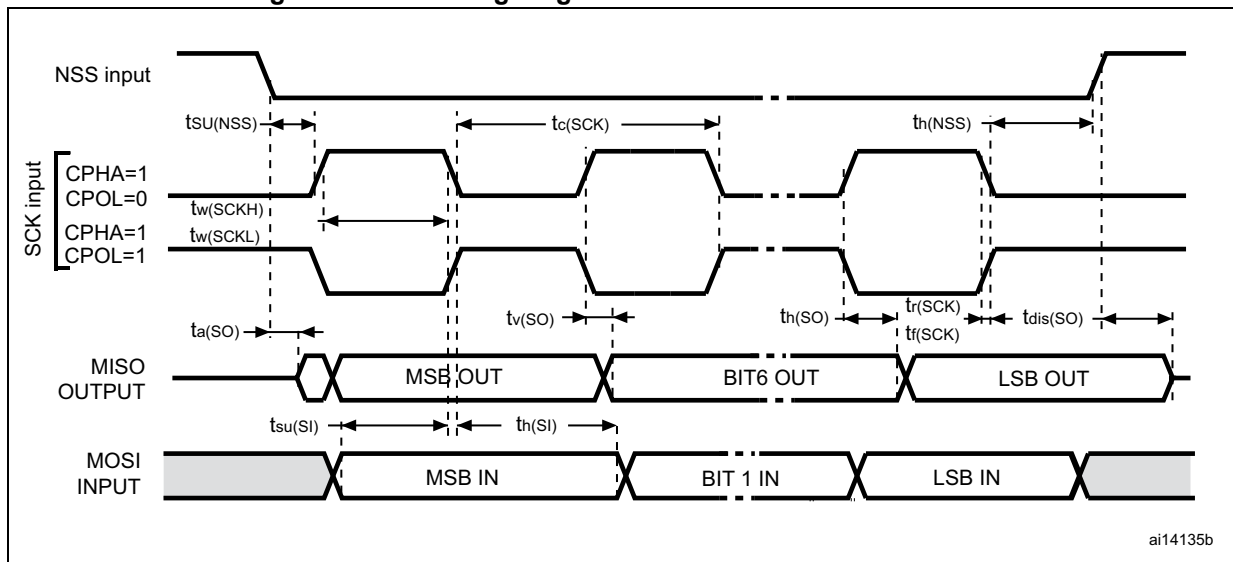
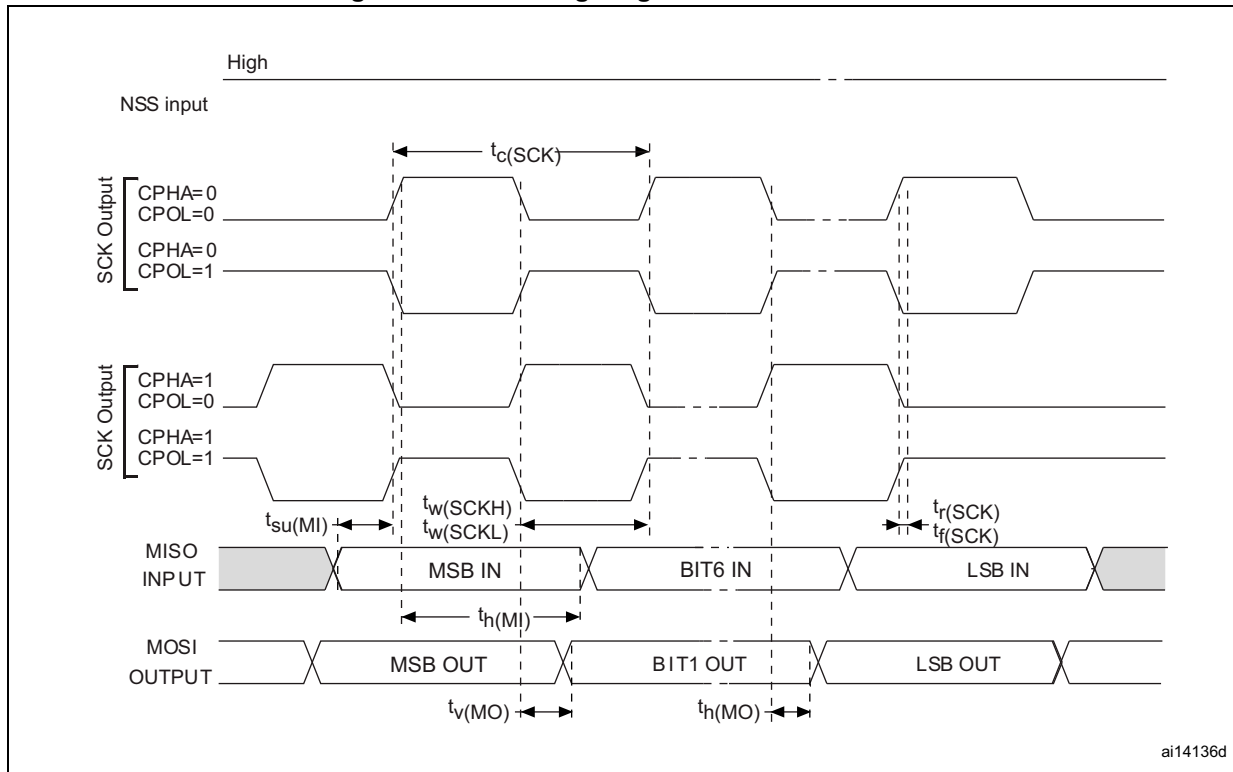

Figure 26. SPI timing diagram - slave mode and CPHA = 1<sup>(1)</sup>



1. Measurement points are done at CMOS levels: 0.3V<sub>DD</sub> and 0.7V<sub>DD</sub>.

Figure 27. SPI timing diagram - master mode<sup>(1)</sup>



1. Measurement points are done at CMOS levels:  $0.3V_{DD}$  and  $0.7V_{DD}$ .



**Inter IC control interface (I2C)**

Subject to general operating conditions for  $V_{DD}$ ,  $f_{MASTER}$ , and  $T_A$  unless otherwise specified.

The STM8L I<sup>2</sup>C interface meets the requirements of the Standard I<sup>2</sup>C communication protocol described in the following table with the restriction mentioned below:

Refer to I/O port characteristics for more details on the input/output alternate function characteristics (SDA and SCL).

**Table 29. I2C characteristics**

Symbol	Parameter	Standard mode I2C		Fast mode I2C <sup>(1)</sup>		Unit
		Min <sup>(2)</sup>	Max <sup>(2)</sup>	Min <sup>(2)</sup>	Max <sup>(2)</sup>	
$t_{w(SCLL)}$	SCL clock low time	4.7	-	1.3	-	$\mu\text{s}$
$t_{w(SCLH)}$	SCL clock high time	4.0	-	0.6	-	
$t_{su(SDA)}$	SDA setup time	250	-	100	-	ns
$t_{h(SDA)}$	SDA data hold time	0 <sup>(3)</sup>	-	0 <sup>(4)</sup>	900 <sup>(3)</sup>	
$t_{r(SDA)}$ $t_{r(SCL)}$	SDA and SCL rise time	-	1000	-	300	
$t_{f(SDA)}$ $t_{f(SCL)}$	SDA and SCL fall time	-	300	-	300	
$t_{h(STA)}$	START condition hold time	4.0	-	0.6	-	$\mu\text{s}$
$t_{su(STA)}$	Repeated START condition setup time	4.7	-	0.6	-	
$t_{su(STO)}$	STOP condition setup time	4.0	-	0.6	-	$\mu\text{s}$
$t_{w(STO:STA)}$	STOP to START condition time (bus free)	4.7	-	1.3	-	$\mu\text{s}$
$C_b$	Capacitive load for each bus line	-	400	-	400	pF

- $f_{SCK}$  must be at least 8 MHz to achieve max fast I<sup>2</sup>C speed (400 kHz).
- Data based on standard I<sup>2</sup>C protocol requirement, not tested in production.
- The maximum hold time of the START condition has only to be met if the interface does not stretch the low period of SCL signal.
- The device must internally provide a hold time of at least 300 ns for the SDA signal in order to bridge the undefined region of the falling edge of SCL).

**Note:** For speeds around 200 kHz, achieved speed can have  $\pm 5\%$  tolerance  
 For other speed ranges, achieved speed can have  $\pm 2\%$  tolerance  
 The above variations depend on the accuracy of the external components used.

Figure 28. Typical application with I2C bus and timing diagram <sup>(1)</sup>

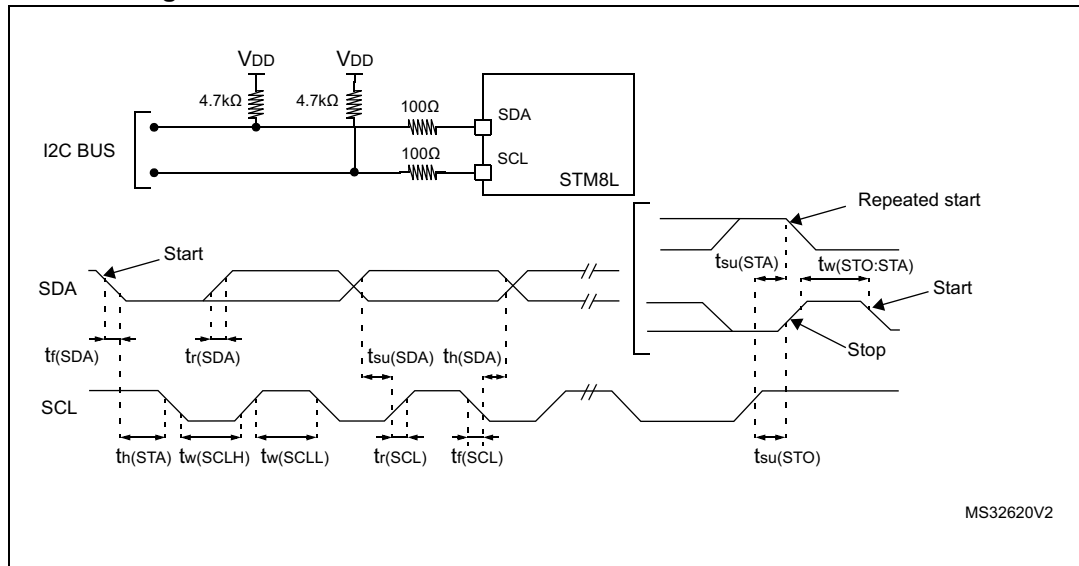

1. Measurement points are done at CMOS levels: 0.3 x V<sub>DD</sub> and 0.7 x V<sub>DD</sub>.

### 8.3.8 Comparator characteristics

Table 30. Comparator characteristics

Symbol	Parameter	Conditions	Min <sup>(1)</sup>	Typ	Max <sup>(1)</sup>	Unit
V <sub>IN(COMP_REF)</sub>	Comparator external reference	-	-0.1	-	V <sub>DD</sub> -1.25	V
V <sub>IN</sub>	Comparator input voltage range	-	-0.25	-	V <sub>DD</sub> +0.25	V
V <sub>offset</sub> <sup>(2)</sup>	Comparator offset error	-	-	-	±20	mV
t <sub>START</sub>	Startup time (after BIAS_EN)	-	-	-	3 <sup>(1)</sup>	µs
I <sub>DD(COMP)</sub>	Analog comparator consumption	-	-	-	25 <sup>(1)</sup>	µA
	Analog comparator consumption during power-down	-	-	-	60 <sup>(1)</sup>	nA
t <sub>propag</sub> <sup>(2)</sup>	Comparator propagation delay	100-mV input step with 5-mV overdrive, input rise time = 1 ns	-	-	2 <sup>(1)</sup>	µs

- Guaranteed by design.
- The comparator accuracy depends on the environment. In particular, the following cases may reduce the accuracy of the comparator and must be avoided:
  - Negative injection current on the I/Os close to the comparator inputs
  - Switching on I/Os close to the comparator inputs
  - Negative injection current on not used comparator input.
  - Switching with a high dV/dt on not used comparator input.
 These phenomena are even more critical when a big external serial resistor is added on the inputs.

### 8.3.9 EMC characteristics

Susceptibility tests are performed on a sample basis during product characterization.

#### Functional EMS (electromagnetic susceptibility)

Based on a simple running application on the product (toggling 2 LEDs through I/O ports), the product is stressed by two electromagnetic events until a failure occurs (indicated by the LEDs).

- **ESD:** Electrostatic discharge (positive and negative) is applied on all pins of the device until a functional disturbance occurs. This test conforms with the IEC 61000-4-2 standard.
- **FTB:** A burst of fast transient voltage (positive and negative) is applied to  $V_{DD}$  and  $V_{SS}$  through a 100 pF capacitor, until a functional disturbance occurs. This test conforms with the IEC 61000-4-4 standard.

A device reset allows normal operations to be resumed. The test results are given in the table below based on the EMS levels and classes defined in application note AN1709.

#### Designing hardened software to avoid noise problems

EMC characterization and optimization are performed at component level with a typical application environment and simplified MCU software. It should be noted that good EMC performance is highly dependent on the user application and the software in particular.

Therefore it is recommended that the user applies EMC software optimization and prequalification tests in relation with the EMC level requested for his application.

Prequalification trials:

To complete these trials, ESD stress can be applied directly on the device, over the range of specification values. When unexpected behavior is detected, the software can be hardened to prevent unrecoverable errors occurring. Refer to application note *Software techniques for improving microcontrollers EMC performance* (AN1015).

Table 31. EMS data

Symbol	Parameter	Conditions	Level/Class
$V_{FESD}$	Voltage limits to be applied on any I/O pin to induce a functional disturbance	SO8N, $V_{DD} = 3.3\text{ V}$	TBD
$V_{EFTB}$	Fast transient voltage burst limits to be applied through 100 pF on $V_{DD}$ and $V_{SS}$ pins to induce a functional disturbance	SO8N, $V_{DD} = 3.3\text{ V}$ , $f_{HSI}$	TBD
		SO8N, $V_{DD} = 3.3\text{ V}$ , $f_{HSI}/2$	TBD

**Electromagnetic interference (EMI)**

Based on a simple application running on the product (toggling 2 LEDs through the I/O ports), the product is monitored in terms of emission. This emission test is in line with the norm SAE J 1752/3 which specifies the board and the loading of each pin.

**Table 32. EMI data (1)**

Symbol	Parameter	Conditions	Monitored frequency band	Max vs.	Unit
				16 MHz	
S <sub>EMI</sub>	Peak level	V <sub>DD</sub> = 3.6 V, T <sub>A</sub> = +25 °C, SO8N conforming to IEC61967-2	0.1 MHz to 30 MHz	TBD	dBμV
			30 MHz to 130 MHz	TBD	
			130 MHz to 1 GHz	TBD	
			SAE EMI Level	TBD	-

1. Not tested in production.

**Absolute maximum ratings (electrical sensitivity)**

Based on two different tests (ESD and LU) using specific measurement methods, the product is stressed in order to determine its performance in terms of electrical sensitivity. For more details, refer to the application note AN1181.

**Electrostatic discharge (ESD)**

Electrostatic discharges (a positive then a negative pulse separated by 1 second) are applied to the pins of each sample according to each pin combination. The sample size depends on the number of supply pins in the device (3 parts\*(n+1) supply pin).

This test conforms to the JESD22-A114A/A115A standard.

**Table 33. ESD absolute maximum ratings**

Symbol	Ratings	Conditions	Maximum value (1)	Unit
V <sub>ESD(HBM)</sub>	Electrostatic discharge voltage (human body model)	T <sub>A</sub> = +25 °C	TBD	V
V <sub>ESD(CDM)</sub>	Electrostatic discharge voltage (charge device model)		TBD	

1. Guaranteed by characterization results.

**Static latch-up**

- **LU:** 2 complementary static tests are required on 10 parts to assess the latch-up performance. A supply overvoltage (applied to each power supply pin) and a current injection (applied to each input, output and configurable I/O pin) are performed on each sample. This test conforms to the EIA/JESD 78 IC latch-up standard. For more details, refer to the application note AN1181.

**Table 34. Electrical sensitivities**

Symbol	Parameter	Class
LU	Static latch-up class	TBD

**8.4 Thermal characteristics**

The maximum chip junction temperature ( $T_{Jmax}$ ) must never exceed the values given in [Table 14: General operating conditions on page 33](#).

The maximum chip-junction temperature,  $T_{Jmax}$ , in degrees Celsius, may be calculated using the following equation:

$$T_{Jmax} = T_{Amax} + (P_{Dmax} \times \Theta_{JA})$$

Where:

- $T_{Amax}$  is the maximum ambient temperature in °C
- $\Theta_{JA}$  is the package junction-to-ambient thermal resistance in °C/W
- $P_{Dmax}$  is the sum of  $P_{INTmax}$  and  $P_{I/Omax}$  ( $P_{Dmax} = P_{INTmax} + P_{I/Omax}$ )
- $P_{INTmax}$  is the product of  $I_{DD}$  and  $V_{DD}$ , expressed in watts. This is the maximum chip internal power.
- $P_{I/Omax}$  represents the maximum power dissipation on output pins where:  
 $P_{I/Omax} = \Sigma (V_{OL} * I_{OL}) + \Sigma ((V_{DD} - V_{OH}) * I_{OH})$ ,  
 taking into account the actual  $V_{OL}/I_{OL}$  and  $V_{OH}/I_{OH}$  of the I/Os at low and high level in the application.

**Table 35. Thermal characteristics<sup>(1)</sup>**

Symbol	Parameter	Value	Unit
$\Theta_{JA}$	Thermal resistance junction-ambient SO8N	102	°C/W

1. Thermal resistances are based on JEDEC JESD51-2 with 4-layer PCB in a natural convection environment.

## 9 Package information

In order to meet environmental requirements, ST offers these devices in different grades of ECOPACK<sup>®</sup> packages, depending on their level of environmental compliance. ECOPACK<sup>®</sup> specifications, grade definitions and product status are available at: [www.st.com](http://www.st.com). ECOPACK<sup>®</sup> is an ST trademark.

### Failure analysis and guarantee

The small number of pins available induces limitations on failure analysis depth in case of isolated symptom, typically with an impact lower than 0.1%. Please contact your sales office for additional information for any failure analysis. STMicroelectronics will make a feasibility study for investigation based on failure rate and symptom description prior to responsibility endorsement.

### 9.1 SO8N package information

Figure 29. SO8N – 8-lead, 4.9 x 6 mm, plastic small outline, 150 mils body width, package outline

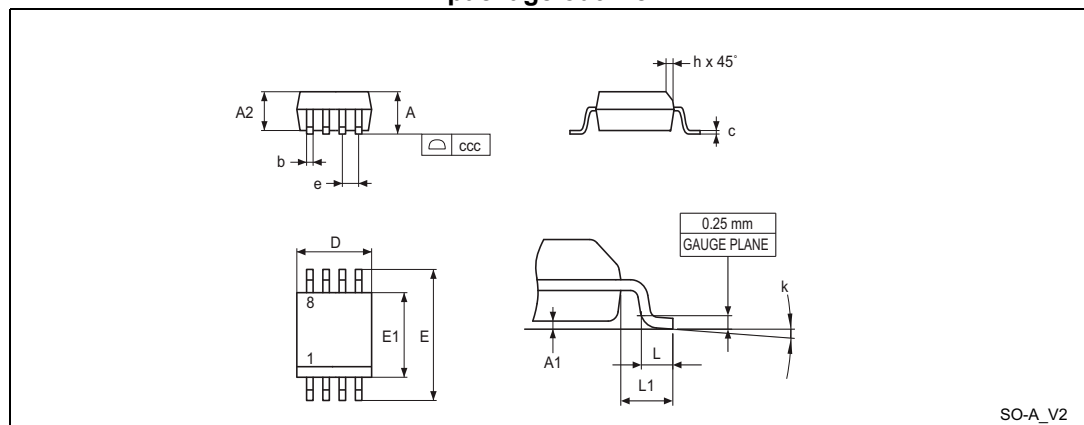

1. Drawing is not to scale.

Table 36. SO8N – 8-lead 4.9 x 6 mm, plastic small outline, 150 mils body width, package mechanical data

Symbol	millimeters			inches <sup>(1)</sup>		
	Min.	Typ.	Max.	Min.	Typ.	Max.
A	-	-	1.750	-	-	0.0689
A1	0.100	-	0.250	0.0039	-	0.0098
A2	1.250	-	-	0.0492	-	-
b	0.280	-	0.480	0.0110	-	0.0189
c	0.170	-	0.230	0.0067	-	0.0091

**Table 36. SO8N – 8-lead 4.9 x 6 mm, plastic small outline, 150 mils body width, package mechanical data (continued)**

Symbol	millimeters			inches <sup>(1)</sup>		
	Min.	Typ.	Max.	Min.	Typ.	Max.
D	4.800	4.900	5.000	0.1890	0.1929	0.1969
E	5.800	6.000	6.200	0.2283	0.2362	0.2441
E1	3.800	3.900	4.000	0.1496	0.1535	0.1575
e	-	1.270	-	-	0.0500	-
h	0.250	-	0.500	0.0098	-	0.0197
k	0°	-	8°	0°	-	8°
L	0.400	-	1.270	0.0157	-	0.0500
L1	-	1.040	-	-	0.0409	-
ccc	-	-	0.100	-	-	0.0039

1. Values in inches are converted from mm and rounded to four decimal digits.

**Figure 30. SO8N – 8-lead 4.9 x 6 mm, plastic small outline, 150 mils body width, package recommended footprint**

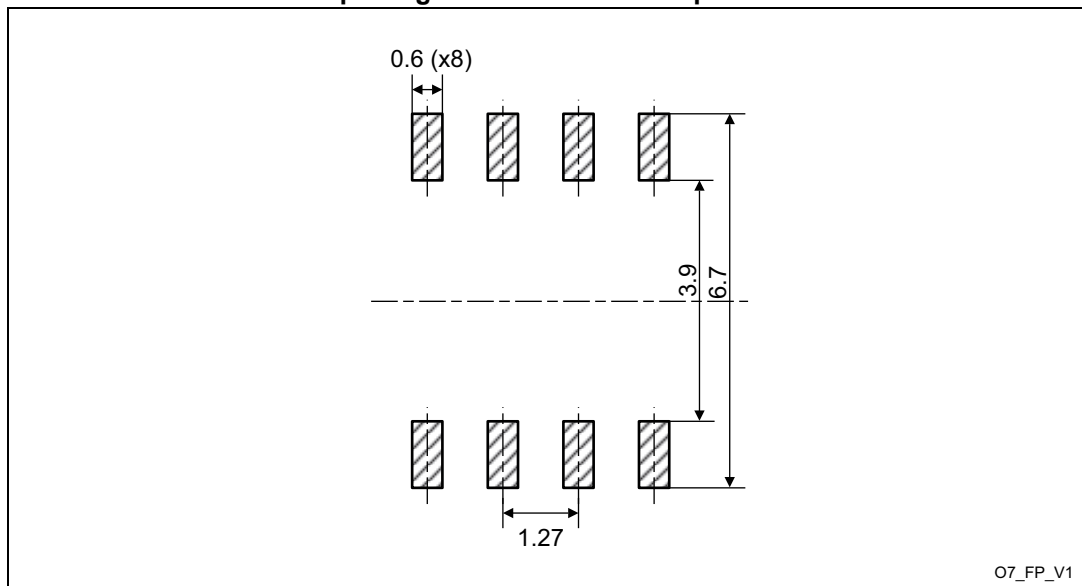

1. Dimensions are expressed in millimeters.
2. Drawing is not to scale.

**Device marking for SO8N – 8-lead 4.9 x 6 mm, plastic small outline, 150 mils body width**

The following figure gives an example of topside marking orientation versus pin 1 identifier location.

Other optional marking or inset/upset marks, which identify the parts throughout supply chain operations, are not indicated below.

**Figure 31. Example of SO8N marking (package top view)**

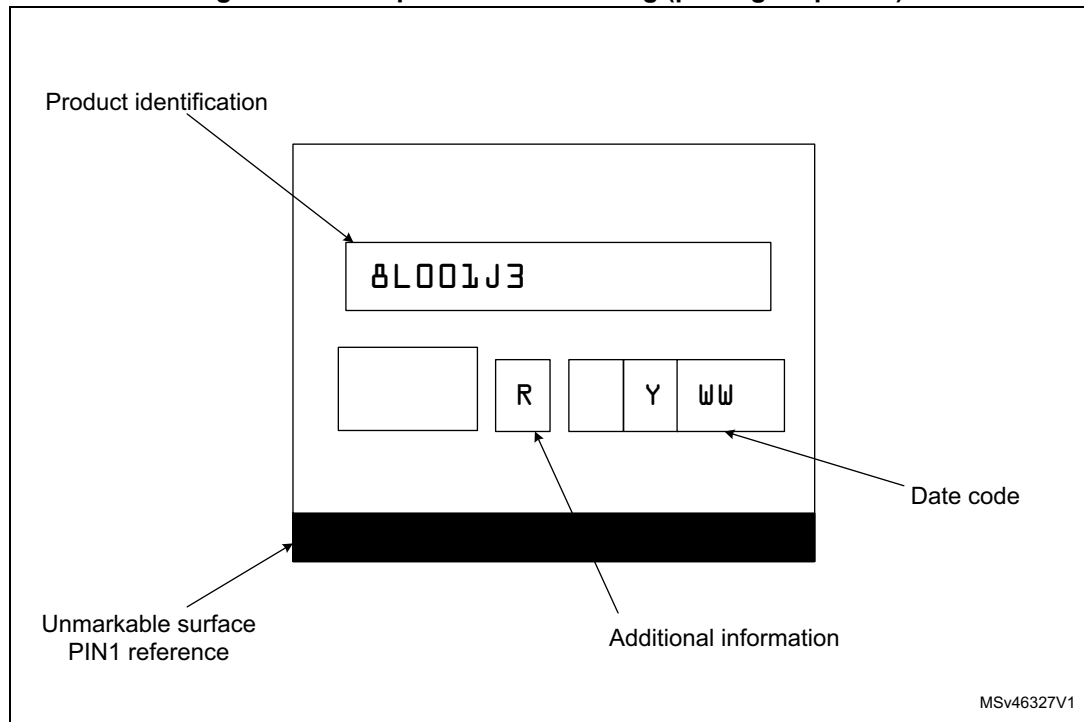

1. Parts marked as ES or E or accompanied by an Engineering Sample notification letter are not yet qualified and therefore not approved for use in production. ST is not responsible for any consequences resulting from such use. In no event will ST be liable for the customer using any of these engineering samples in production. ST's Quality department must be contacted prior to any decision to use these engineering samples to run a qualification activity.



# 10 Ordering information

**Table 37. Ordering information scheme**

Example:	STM8	L	001	J	3	M	3
<b>Device family</b>							
STM8 microcontroller							
<b>Family type</b>							
L = Low power							
<b>Sub family type</b>							
00x = Value line sub-family							
001 = Low density							
<b>Pin count</b>							
J = 8 pins							
<b>Program memory size</b>							
3 = 8 Kbytes							
<b>Package</b>							
M = SO8N							
<b>Temperature range</b>							
3 = -40°C to 125°C							

1. For a list of available options (e.g. memory size, package) and order-able part numbers or for further information on any aspect of this device, please go to [www.st.com](http://www.st.com) or contact the ST Sales Office nearest to you.

# 11 Revision history

**Table 38. Document revision history**

Date	Revision	Changes
06-Jun-2017	1	Initial release.
04-Oct-2017	2	Updated: <ul style="list-style-type: none"><li>– Document's confidentiality level to <i>public</i></li><li>– <a href="#">Section 1: Introduction</a></li><li>– <a href="#">Section 2: Description</a></li><li>– <a href="#">Section 9: Package information</a></li><li>– <a href="#">Figure 26: SPI timing diagram - slave mode and CPHA = 1<sup>(1)</sup></a></li><li>– <a href="#">Figure 27: SPI timing diagram - master mode<sup>(1)</sup></a></li><li>– <a href="#">Figure 28: Typical application with I2C bus and timing diagram (1)</a></li></ul>
04-Jul-2018	3	Updated: <ul style="list-style-type: none"><li>– <a href="#">Recommendations for SWIM pin (pin#1) on Section 3.3: Single wire data interface (SWIM) and debug module</a></li></ul>

**IMPORTANT NOTICE – PLEASE READ CAREFULLY**

STMicroelectronics NV and its subsidiaries ("ST") reserve the right to make changes, corrections, enhancements, modifications, and improvements to ST products and/or to this document at any time without notice. Purchasers should obtain the latest relevant information on ST products before placing orders. ST products are sold pursuant to ST's terms and conditions of sale in place at the time of order acknowledgement.

Purchasers are solely responsible for the choice, selection, and use of ST products and ST assumes no liability for application assistance or the design of Purchasers' products.

No license, express or implied, to any intellectual property right is granted by ST herein.

Resale of ST products with provisions different from the information set forth herein shall void any warranty granted by ST for such product.

ST and the ST logo are trademarks of ST. All other product or service names are the property of their respective owners.

Information in this document supersedes and replaces information previously supplied in any prior versions of this document.

© 2018 STMicroelectronics – All rights reserved