

NUMBER  
201589

USED ON

- OBSOLETE** 201589 -1 1. AS SHOWN.
- OBSOLETE** 201589 -2 1. SAME AS -1 EXCEPT;  
2. FINISH OF ITEM 1, .0001 MIN SILVER OVER .00005 MIN NI
- OBSOLETE** 201589 -3 1. SAME AS -1 EXCEPT;  
2. FINISH OF ITEM 1, .0001 MIN GOLD OVER .0001 MIN SILVER
- OBSOLETE 201589 -4** 1. SAME AS -1 EXCEPT;  
2. MTD ON TAPE.

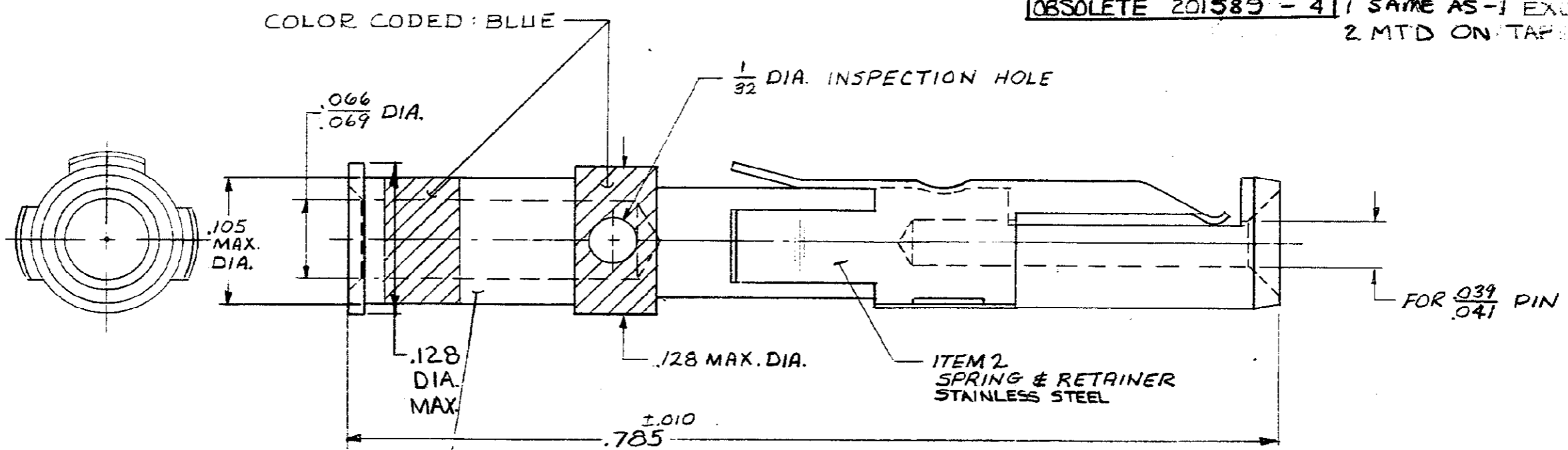

ITEM 1  
SOCKET BODY  
COPPER ALLOY  
.00003 MIN GOLD OVER .00005 MIN NICKEL

**WHEN ORDERING CONTACT ON TAPE, ORDER BY THE TAPE NUMBER PLUS THE PACKAGING CODE AS FOLLOWS:**

1. FOR USE WITH AMP TAPETRONIC, PNEUMATIC TOOL—
  - A. 1000 PARTS TO A BOX ADD PACKAGING CODE: 1MBOX
2. FOR USE WITH 4/8 INDENT STRIPPER CRIMPER—
  - A. 1000 PARTS TO A REEL ADD PACKAGING CODE: 1MREEL
  - B. 5000 PARTS TO A REEL ADD PACKAGING CODE: 5MREEL

DIMENSIONS IN INCHES. DO NOT SCALE PRINT.  
PROPOSAL NO. C/PW-461-X13

PRINT DIST  
39

M	OBS-24-3 ECN BD3038		2.6.10.87
L	REV PER ECN BD2619		11/13/89
K	OBSOLETE -4 PER	S 4350	MWD 12-87
J	REVISED	S 4442	THW 9-87
H	INACTIVATED -4	J 003	2/24/86
G	REV. PER ECN	B 838	2/24/86
F	NOTE ADDED	B 141	1/18/77
E	REV RETAINER SPRING TO SST	Z 808	10/20/76
D	AGE -4	Z 361	7-7-8
C	REVISED	W-525	8/27/73
B	REVISED	U-5	8-22-73
A	REVISED	S 341	1/14/72
A	REVISED	R 774	1/14/71
LTR	REVISION RECORD	ECA	BY DATE

REF: 1950-317-35

© 1961 BY AMP INC. HARRISBURG, PENNA.  
AMP PATENTS COVERED BY PATENTS  
U.S. PATENT PENDING

MATERIAL SEE CALL OUT	DR J. Ruff 11/10/61	ENGR J. S. ... 11-16-61
HEAT TREAT H	CHK J. Ruff 11-30-61	APP J. Ruff 11/16/61
FINISH SEE CALL OUT	<b>AMP</b> AMP INCORPORATED HARRISBURG, PENNA.	
NAME #20 SOCKET CONTACT ASSY		
WIRE SIZE 18-16		
SCALE 10:1	LOC BD	NO 201589
		REV M

TO  
EXCEPT AS NOTED  
DECIMALS = 005  
FRACTIONS = 1/16