

Apr.1.2017 Copyright 2017 HIROSE ELECTRIC CO., LTD. All Rights Reserved.

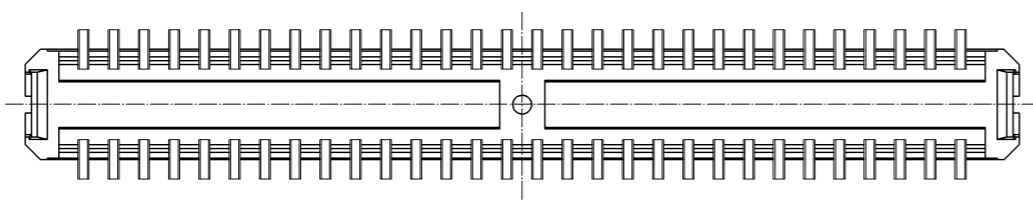
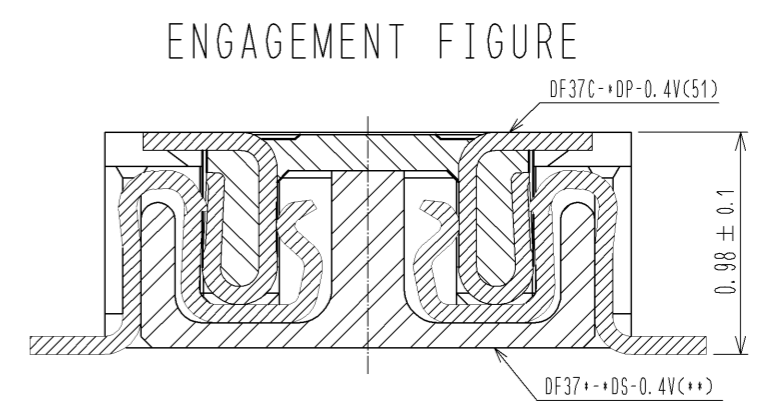
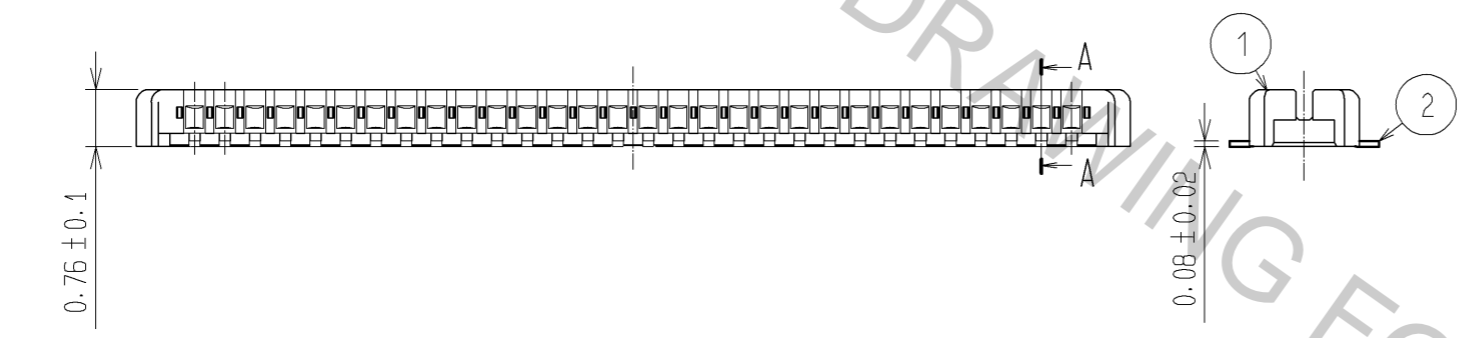
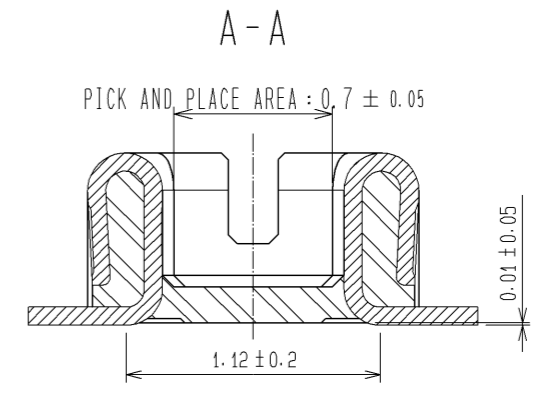
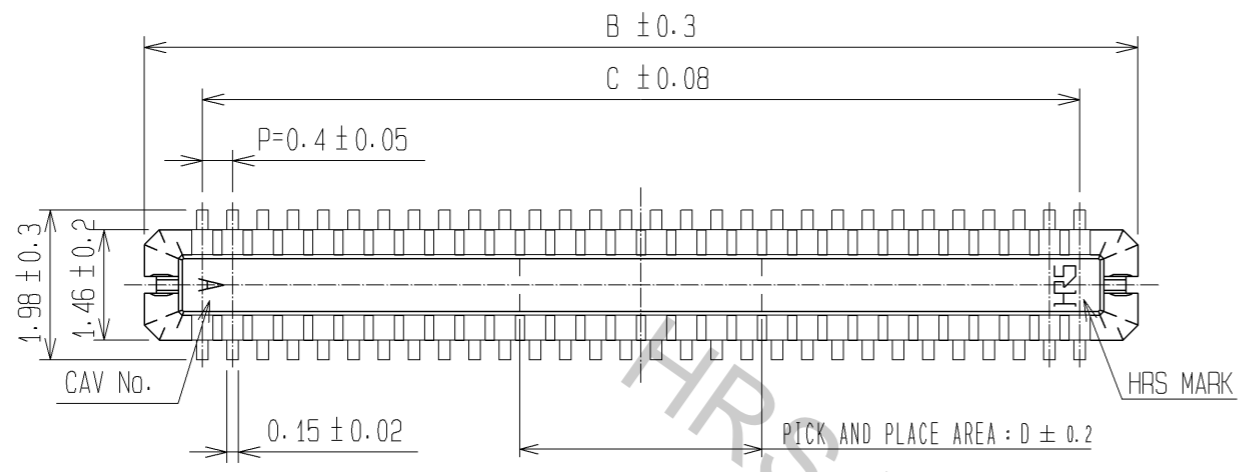

PART No.	CL No.	B	C	D
DF37C-10DP-0.4V(51)	CL684-3039-5-51	3.14	1.6	0.8
DF37C-16DP-0.4V(51)	CL684-3058-0-51	4.34	2.8	1.2
DF37C-20DP-0.4V(51)	CL684-3024-8-51	5.14	3.6	1.6
DF37C-24DP-0.4V(51)	CL684-3025-0-51	5.94	4.4	2.0
DF37C-30DP-0.4V(51)	CL684-3026-3-51	7.14	5.6	2.0
△ DF37C-34DP-0.4V(51)	CL684-3085-2-51	7.94	6.4	2.4
DF37C-40DP-0.4V(51)	CL684-3027-6-51	9.14	7.6	2.4
△ DF37C-44DP-0.4V(51)	CL684-3089-3-51	9.94	8.4	2.8
DF37C-50DP-0.4V(51)	CL684-3028-9-51	11.14	9.6	2.8
DF37C-60DP-0.4V(51)	CL684-3029-1-51	13.14	11.6	3.2
△ DF37C-70DP-0.4V(51)	CL684-3030-0-51	15.14	13.6	3.6
△ DF37C-74DP-0.4V(51)	CL684-3073-3-51	15.94	14.4	4.0

NOTE 1. ALL LEADS CO-PLANARITY SHALL BE 0.1 mm MAX.
 2 CONTACT PLATING SPECIFICATIONS.
 CONTACT AREA : GOLD 0.05 μm MIN
 SMT LEAD : GOLD 0.05 μm MIN
 UNDER PLATING : NICKEL 1 μm MIN
 (SURFACE : SEALING)

2	PHOSPHOR BRONZE	2	5	PS	BLACK, PLASTIC REEL							
1	LCP	BLACK, UL94V-0	4	POLYESTER	CLEAR, COVER TAPE							
			3	PS	CLEAR, EMBOSSED CARRIER TAPE							
NO.	MATERIAL	FINISH, REMARKS	NO.	MATERIAL	FINISH, REMARKS							
UNITS	mm	SCALE	FREE	COUNT	12	DESCRIPTION OF REVISIONS	DESIGNED	CR. AJITO	CHECKED	TS. MIYAZAKI	DATE	11.02.09
HRS HIROSE ELECTRIC CO., LTD.		APPROVED : MO. NAKAMURA	07.01.29	DRAWING NO.		EDC3-314974-01						
		CHECKED : KH. IKEDA	07.01.29	PART NO.		DF37C-*DP-0.4V(51)						
		DESIGNED : KY. MIDORIKAWA	07.01.29	CODE NO.								
		DRAWN : KY. MIDORIKAWA	07.01.29									

◆ RECOMMENDED PCB LAYOUT (MOUNTING SURFACE SIDE)

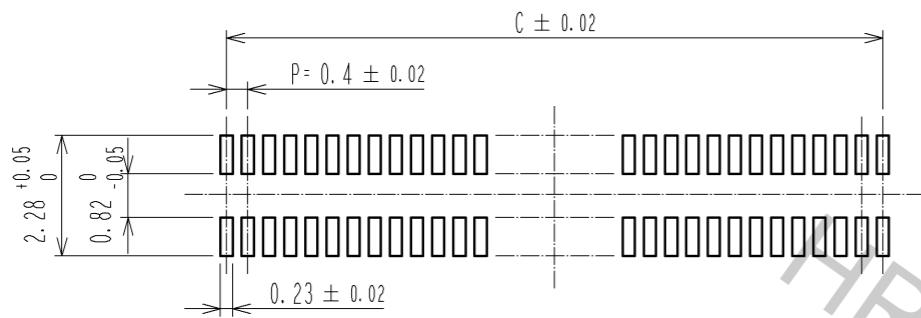

◆ RECOMMENDED METAL MASK DIMENSIONS
METAL MASK THICKNESS : 0.12mm

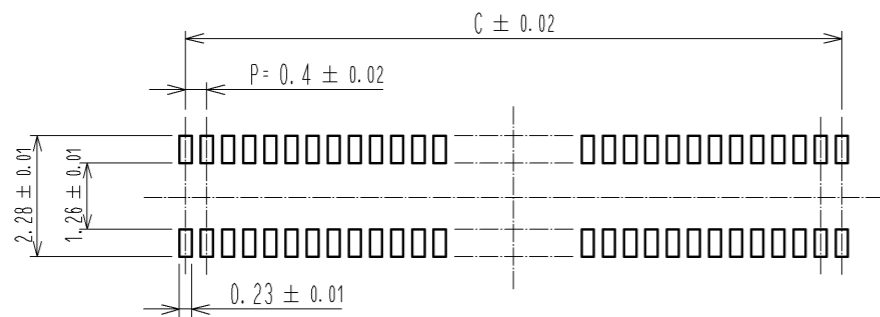

◆ RECOMMENDED METAL MASK DIMENSIONS
METAL MASK THICKNESS : 0.1mm

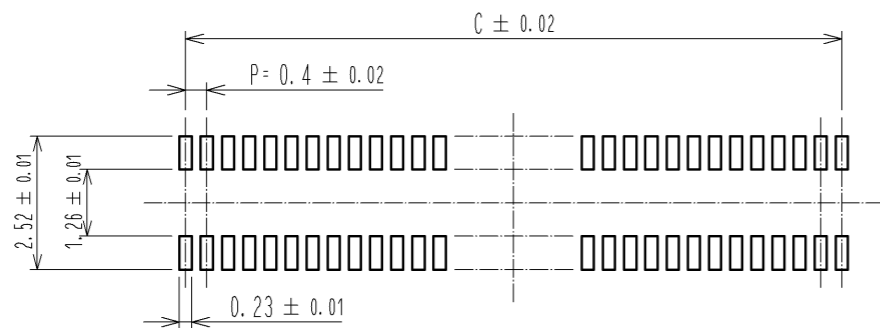

③ RECOMMENDED REFLOW TEMPERATURE PROFILE USING LEAD-FREE SOLDER PASTE.

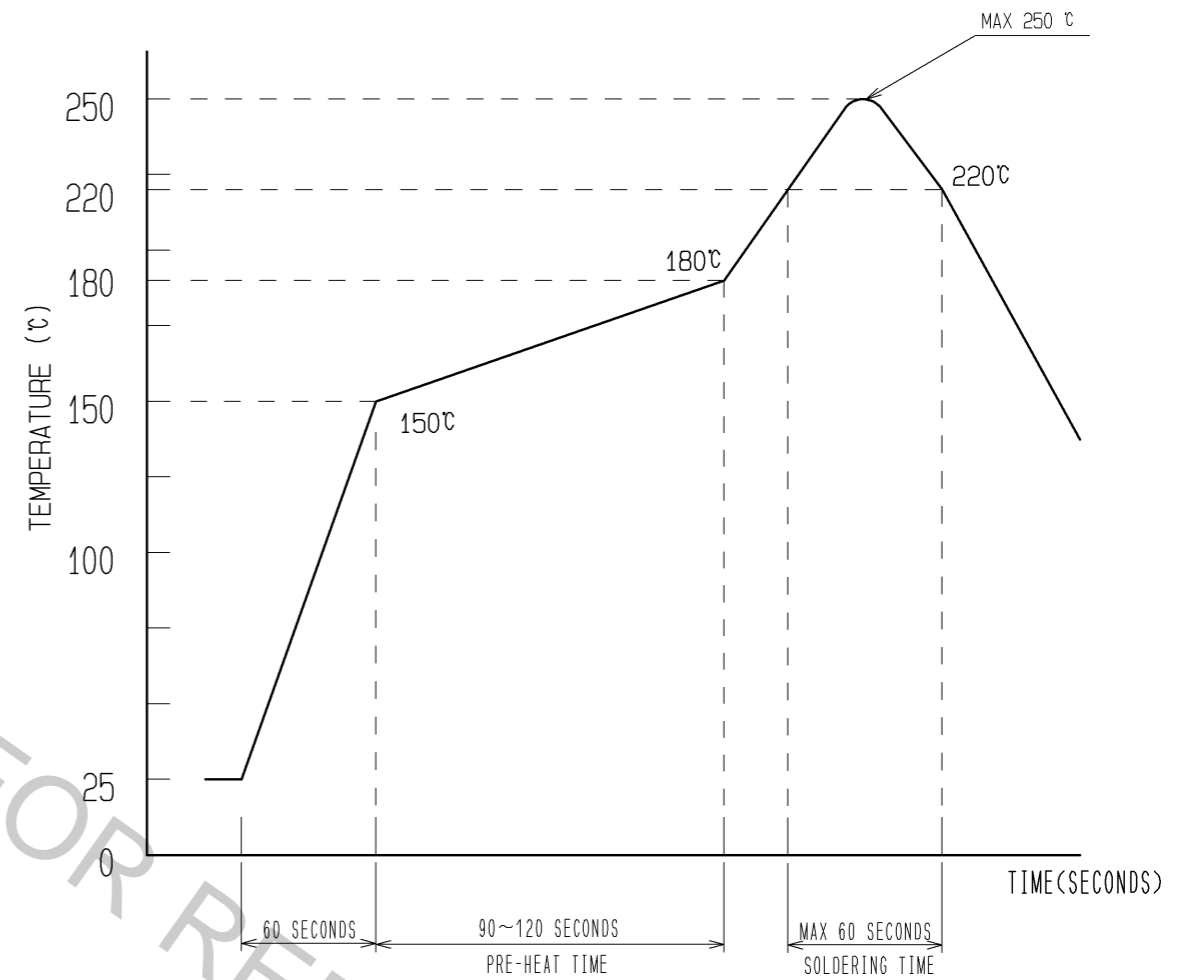

- 1) REFLOW TIME
REFLOW METHOD: IR REFLOW
NUMBER OF REFLOW CYCLES: 2 CYCLES MAX.
DURATION ABOVE 220 °C. 60 SEC. MAX.
(PEAK TEMPERATURE: 250°C MAX.)
- 2) PRE-HEAT TIME
PRE-HEAT TEMPERATURE(MIN) :150 °C
PRE-HEAT TEMPERATURE(MAX) :180 °C
PRE-HEAT TIME : 90~120 sec.

PART No.	C
DF37C-10DP-0.4V(51)	1.6
DF37C-16DP-0.4V(51)	2.8
DF37C-20DP-0.4V(51)	3.6
DF37C-24DP-0.4V(51)	4.4
DF37C-30DP-0.4V(51)	5.6
DF37C-34DP-0.4V(51)	6.4
DF37C-40DP-0.4V(51)	7.6
DF37C-44DP-0.4V(51)	8.4
DF37C-50DP-0.4V(51)	9.6
DF37C-60DP-0.4V(51)	11.6
DF37C-70DP-0.4V(51)	13.6
DF37C-74DP-0.4V(51)	14.4

③ THIS TEMPERATURE PROFILE IS PER THE CONDITIONS SHOWN ABOVE. ADDITIONAL FACTORS, SUCH AS SOLDER PASTE TYPE, PCB SIZE AND OTHER MOUNTED COMPONENTS COULD AFFECT THE PROFILE. THEREFORE, A THOROUGH EVALUATION OF MOUNTING CONDITION IS REQUIRED PRIOR TO PRODUCTION. TEMPERATURE IS MEASURED AT CONTACT LEAD.

HRS	DRAWING NO.	EDC3-314974-01
	PART NO.	DF37C-*DP-0.4V(51)
	CODE NO.	

EMBOSSED CARRIER TAPE PACKAGING (FREE SIZE)

◆ LESS THAN 70 POS.

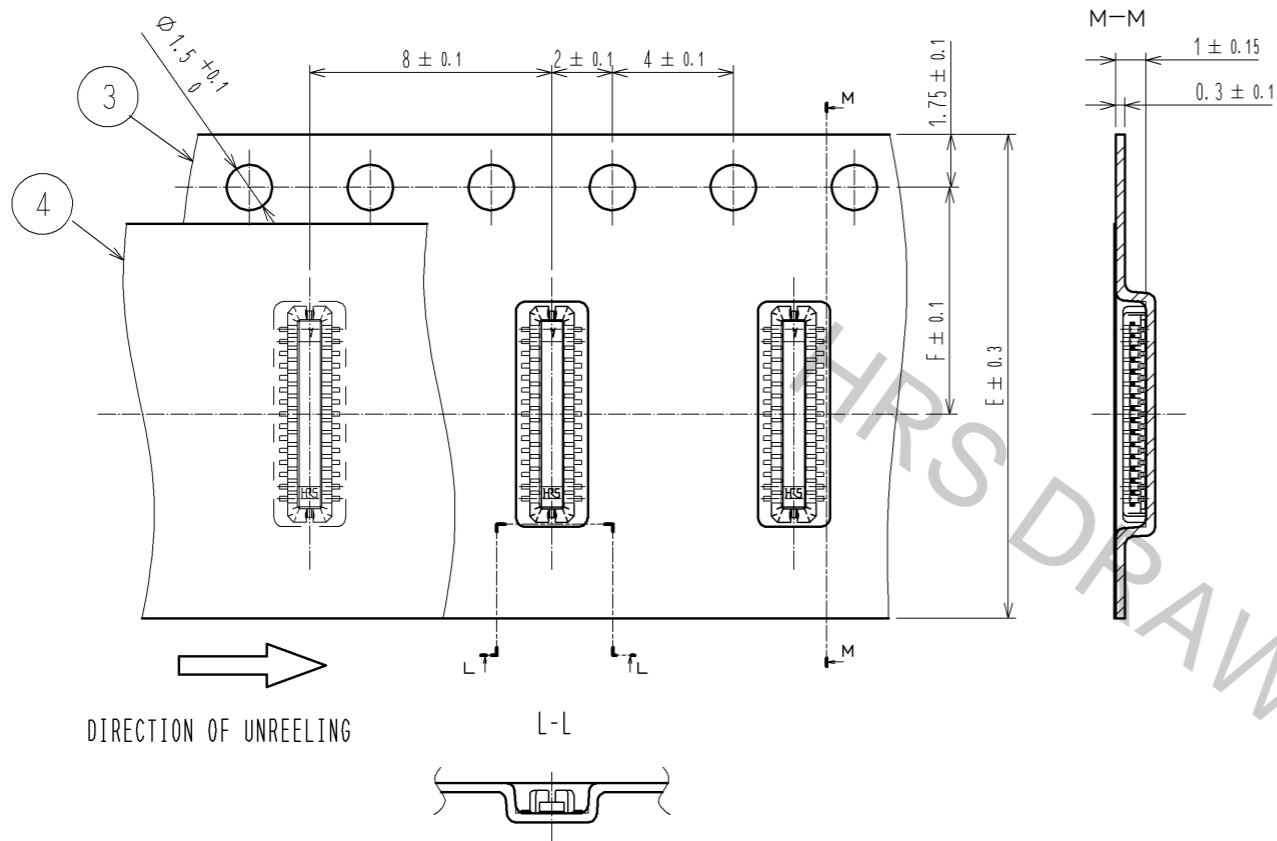

EMBOSSED CARRIER TAPE PACKAGING (FREE SIZE)

◆ 74 POS.

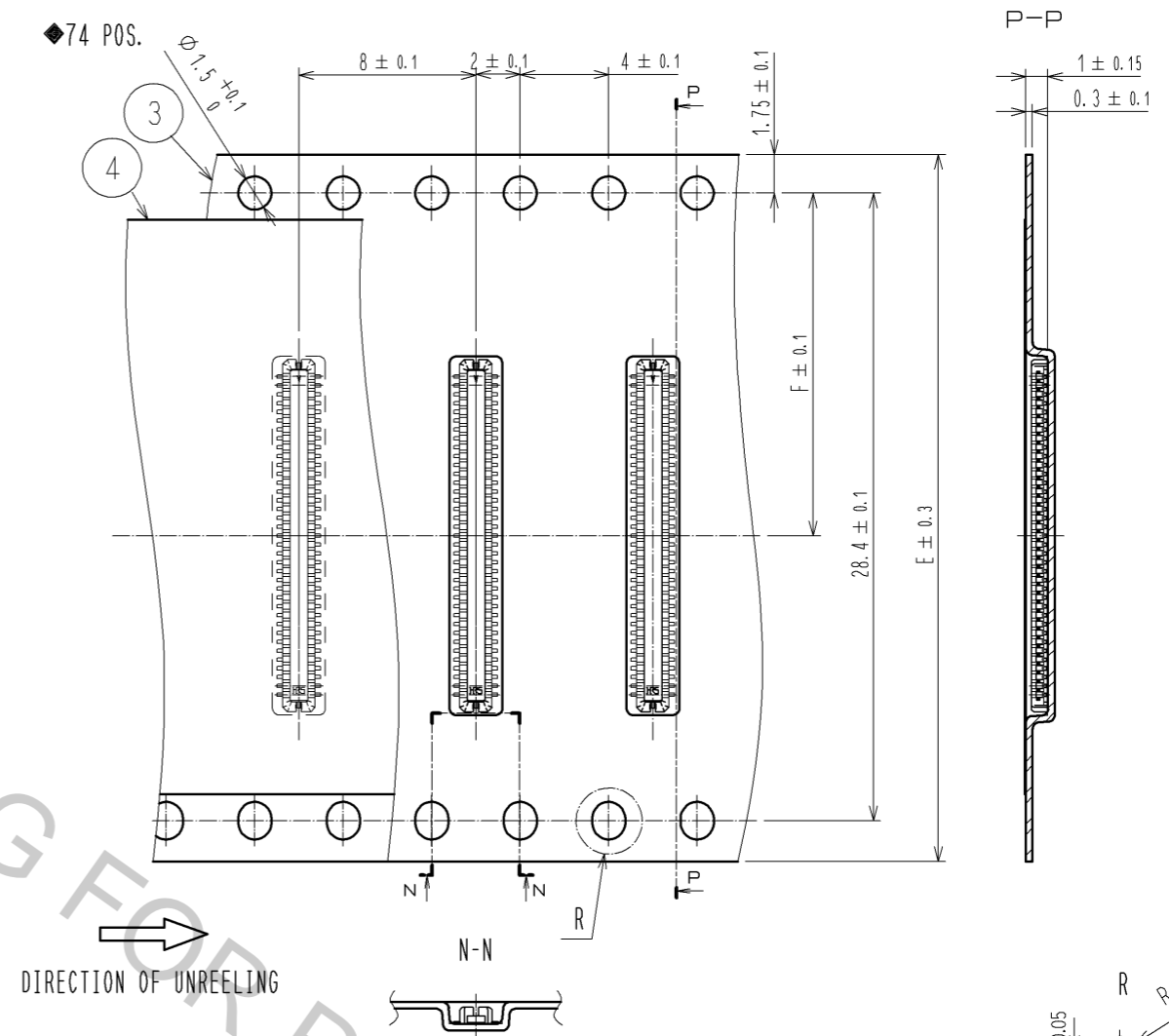

STYLE AND DIMENSION OF REEL (FREE SIZE)

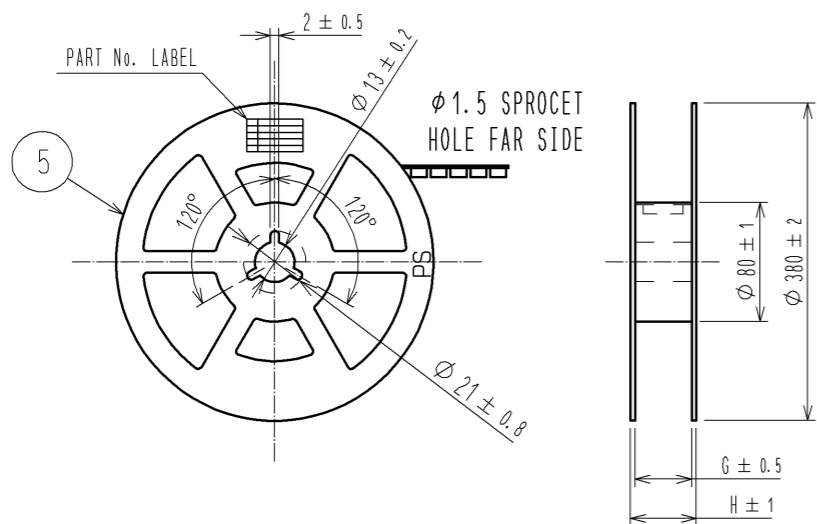

7 DETAIL OF PART No. LABEL

SUPPLIER	
QUANTITY	
PART NO.	
CODE NO.	
DATE OF MANUFACTURED	
製造年月日	年 月 日
製品コード	** ** *
製品名	DF37C- <i>DP</i> -0.4V(51)
数量	8000個
納入者	ヒロセ電機(株)

PART No.	E	F	G	H
DF37C-10DP-0.4V(51)	12	5.5	13.5	17.5
DF37C-16DP-0.4V(51)	16	7.5	17.5	21.5
DF37C-20DP-0.4V(51)	16	7.5	17.5	21.5
DF37C-24DP-0.4V(51)	16	7.5	17.5	21.5
DF37C-30DP-0.4V(51)	16	7.5	17.5	21.5
DF37C-34DP-0.4V(51)	16	7.5	17.5	21.5
DF37C-40DP-0.4V(51)	24	11.5	25.5	29.5
DF37C-44DP-0.4V(51)	24	11.5	25.5	29.5
DF37C-50DP-0.4V(51)	24	11.5	25.5	29.5
DF37C-60DP-0.4V(51)	24	11.5	25.5	29.5
DF37C-70DP-0.4V(51)	24	11.5	25.5	29.5
DF37C-74DP-0.4V(51)	32	14.2	33.5	37.5

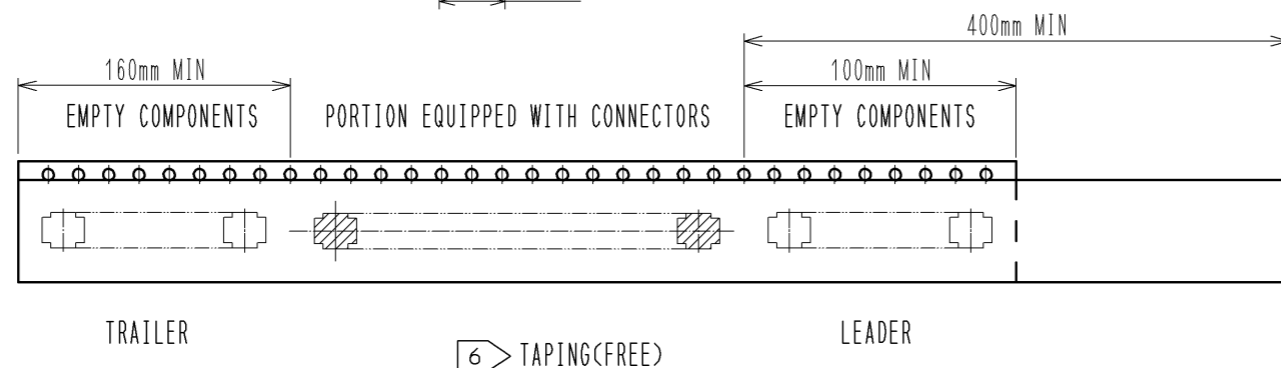

NOTES 4. PER REEL 8000 CONNECTORS.

5. THE DIMENSIONS IN PARENTHESSES ARE FOR REFERENCE.

6 REFER TO JIS C 0806(PACKING OF COMPONENTS FOR AUTOMATIC HANDLING)

7 DETAIL OF PART No. LABEL IS WRITTEN IN JAPANESE.

HRS

DRAWING NO.	EDC3-314974-01
PART NO.	DF37C- <i>DP</i> -0.4V(51)
CODE NO.	

3/3