



FRDM-33931-EVB Evaluation Board

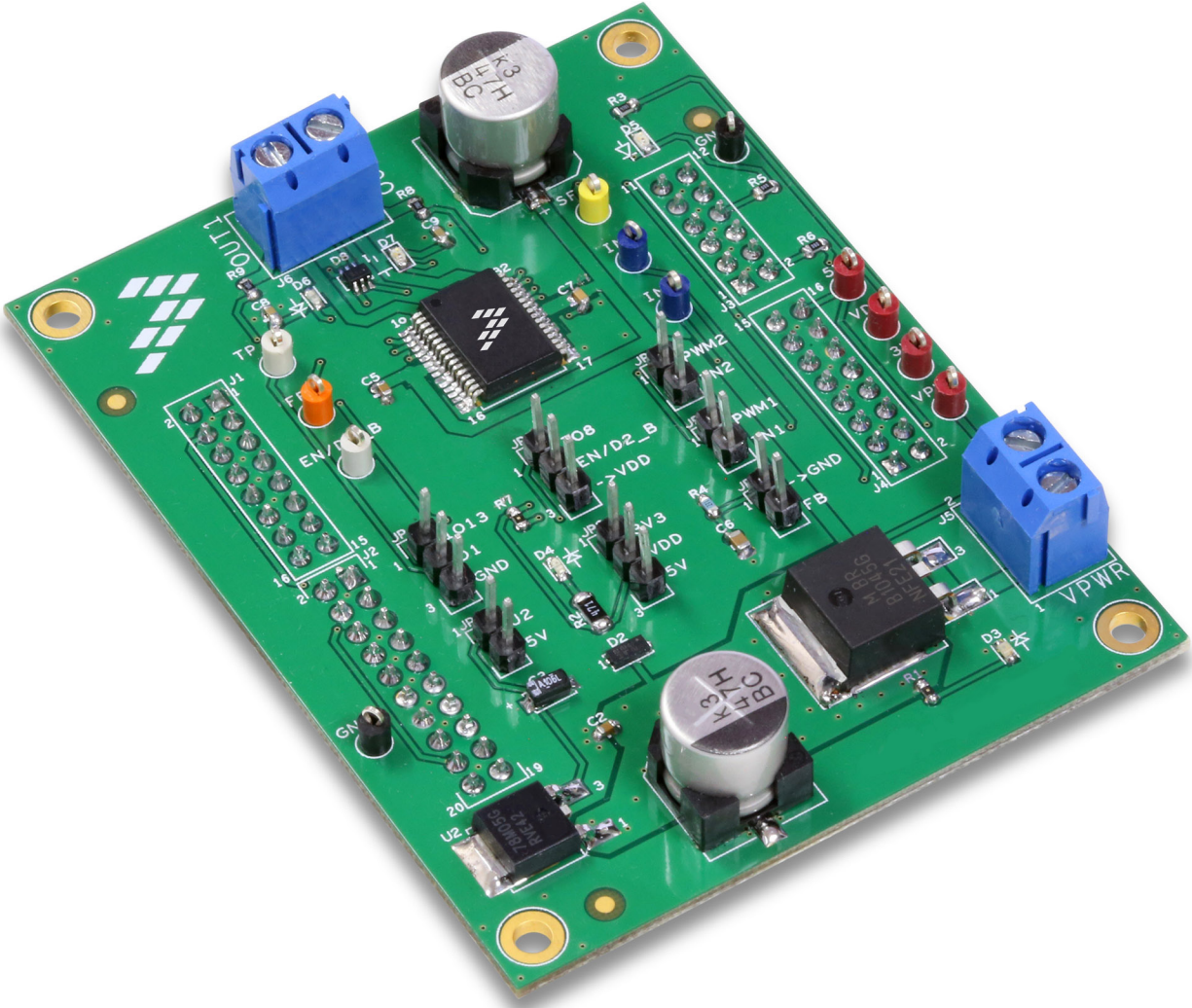

Figure 1. FRDM-33931-EVB



Table of Contents

1	Important Notice	3
2	Getting Started	4
3	Getting to Know the Hardware	5
4	FRDM-KL25Z Freedom Development Platform	14
5	Setting up the Hardware and the Graphical User Interface (GUI)	18
6	Schematic	30
7	Board Layout	31
8	Board Bill of Materials	32
9	Accessory Item Bill of Materials	34
10	References	35
11	Revision History	36

1 Important Notice

Freescale provides the enclosed product(s) under the following conditions:

This evaluation kit is intended for use of ENGINEERING DEVELOPMENT OR EVALUATION PURPOSES ONLY. It is provided as a sample IC pre-soldered to a printed circuit board to make it easier to access inputs, outputs, and supply terminals. This evaluation board may be used with any development system or other source of I/O signals by simply connecting it to the host MCU or computer board via off-the-shelf cables. This evaluation board is not a Reference Design and is not intended to represent a final design recommendation for any particular application. Final device in an application will be heavily dependent on proper printed circuit board layout and heat sinking design as well as attention to supply filtering, transient suppression, and I/O signal quality.

The goods provided may not be complete in terms of required design, marketing, and or manufacturing related protective considerations, including product safety measures typically found in the end product incorporating the goods. Due to the open construction of the product, it is the user's responsibility to take any and all appropriate precautions with regard to electrostatic discharge. In order to minimize risks associated with the customers applications, adequate design and operating safeguards must be provided by the customer to minimize inherent or procedural hazards. For any safety concerns, contact Freescale sales and technical support services.

Should this evaluation kit not meet the specifications indicated in the kit, it may be returned within 30 days from the date of delivery and will be replaced by a new kit.

Freescale reserves the right to make changes without further notice to any products herein. Freescale makes no warranty, representation or guarantee regarding the suitability of its products for any particular purpose, nor does Freescale assume any liability arising out of the application or use of any product or circuit, and specifically disclaims any and all liability, including without limitation consequential or incidental damages. "Typical" parameters can and do vary in different applications and actual performance may vary over time. All operating parameters, including "Typical", must be validated for each customer application by customer's technical experts.

Freescale does not convey any license under its patent rights nor the rights of others. Freescale products are not designed, intended, or authorized for use as components in systems intended for surgical implant into the body, or other applications intended to support or sustain life, or for any other application in which the failure of the Freescale product could create a situation where personal injury or death may occur.

Should the Buyer purchase or use Freescale products for any such unintended or unauthorized application, the Buyer shall indemnify and hold Freescale and its officers, employees, subsidiaries, affiliates, and distributors harmless against all claims, costs, damages, and expenses, and reasonable attorney fees arising out of, directly or indirectly, any claim of personal injury or death associated with such unintended or unauthorized use, even if such claim alleges Freescale was negligent regarding the design or manufacture of the part. Freescale™ and the Freescale logo are trademarks of Freescale Semiconductor, Inc. All other product or service names are the property of their respective owners. © Freescale Semiconductor, Inc. 2015

2 Getting Started

2.1 Kit Contents/Packing List

The **FRDM-33931-EVB** contents include:

- Assembled and tested evaluation board/module in anti-static bag
- Warranty card

2.2 Jump Start

Freescale's analog product development boards provide an easy-to-use platform for evaluating Freescale products. They support a range of analog, mixed-signal and power solutions. The boards incorporate monolithic ICs and system-in-package devices that use proven high-volume SMARTMOS technology. Freescale products enable longer battery life, smaller form factor, component count reduction, ease of design, lower system cost and improved performance in powering state of the art systems.

All product development boards are accompanied by a Jump Start bundle available on the board's Tool Summary Page. Jump Start bundles offer the most current version of the resources that support the development board. The bundles contain everything you need to begin using the Freescale development board in your environment.

To access the Jump Start bundle for the FRDM-33931-EVB:

- Go to www.freescale.com/FRDM-33931-EVB
- Review your Tool Summary Page
- Look for



- Download the documents, software and other resources

2.3 Required Equipment and Software

To use this kit, you need:

- DC Power supply: 5.0 V to 40 V with up to 10 A current handling capability, depending on motor requirements.
- USB Standard A (male) to mini-B (male) cable
- Typical loads (brushed DC motor, power resistors or inductive load with up to 5.0 A and 28 V operation)
- Function generator (optional)
- FRDM-KL25Z Freedom Development Platform (optional)
- ARM@MBED™ firmware loaded on FRDM-KL25Z board (To compile the code, you need to have an account in www.mbed.org.)
- MC33931 microcode loaded on FRDM-KL25Z
- Graphical User Interface required for use with FRDM-KL25Z

2.4 System Requirements

The kit requires the following to function properly with the software:

- A USB enabled computer with Windows® XP or later (required only if FRDM-KL25Z is used)

3.4 Device Features

This evaluation board features the following Freescale product:

Table 1. MC3491 Device Features

Device	Description	Features
MC33931	The 33931 is a monolithic H-Bridge Power IC in a robust thermally enhanced 32 pin SOIC-EP package.	<ul style="list-style-type: none"> 5.0 V to 28 V continuous operation (transient operation from 5.0 V to 40 V) 3.0 V and 5.0 V TTL / CMOS logic compatible inputs 235 mΩ maximum $R_{DS(on)}$ at $T_J = 150\text{ }^\circ\text{C}$ (each H-Bridge MOSFET) Overcurrent limiting (regulation) via internal constant-off-time PWM Output short-circuit protection (short to VPWR or GND) Temperature-dependent current-limit threshold reduction Sleep mode with current draw < 50 μA

3.5 Operation Modes

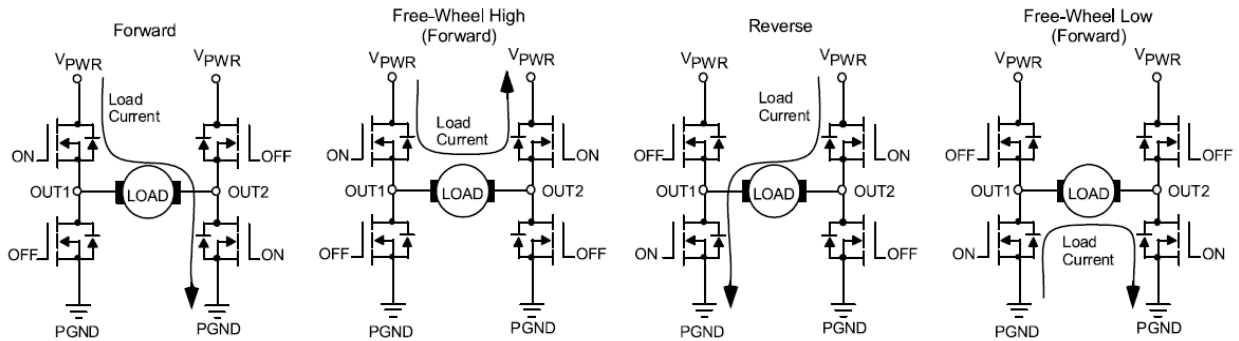

Figure 3. Operation Modes

3.6 Architecture

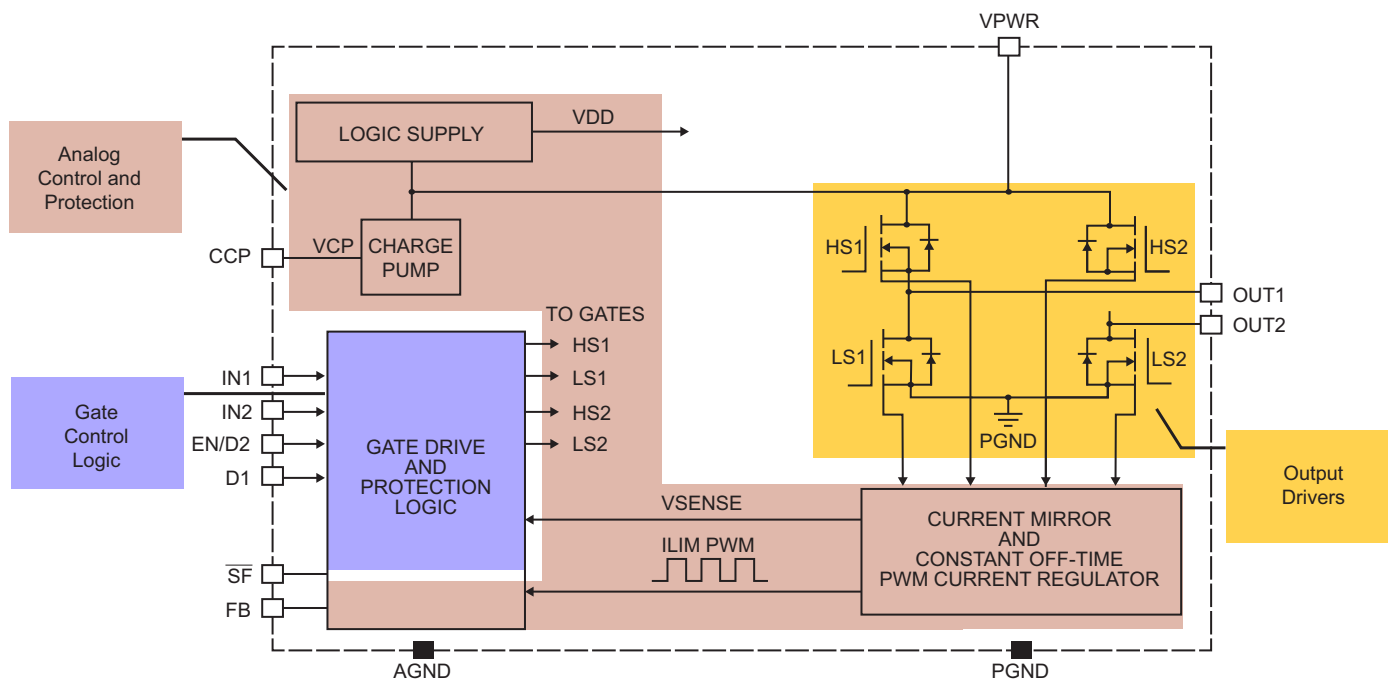
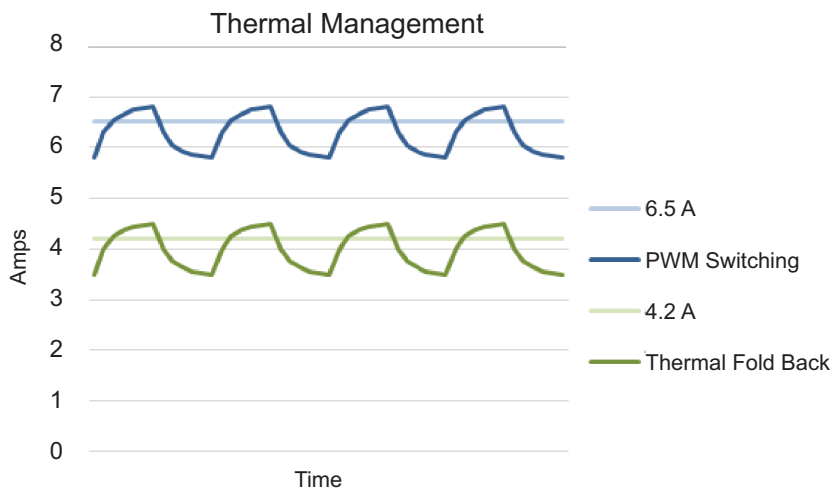

Figure 4. General Architecture Diagram

3.7 Thermal Management



Thermal management

- **PWM switching**
 - to 6.5 A at < 165 °C
 - Below 165 °C, the device PWMs the outputs, averaging under 6.5 A to reduce thermals while continuing operation
- **Thermal fold back**
 - to 4.2 A at 165 °C < T < 185 °C
 - Above 165 °C, the device goes into thermal fold back, averaging under 4.2 A to reduce thermals while continuing operation
- **Thermal shutdown**
 - at 175 °C < T < 200 °C
 - The device shuts down

Figure 5. Thermal Management (Thermal Fold-back)

3.8 Board Description

Figure 6 and Table 2 describes the main blocks of the evaluation board.

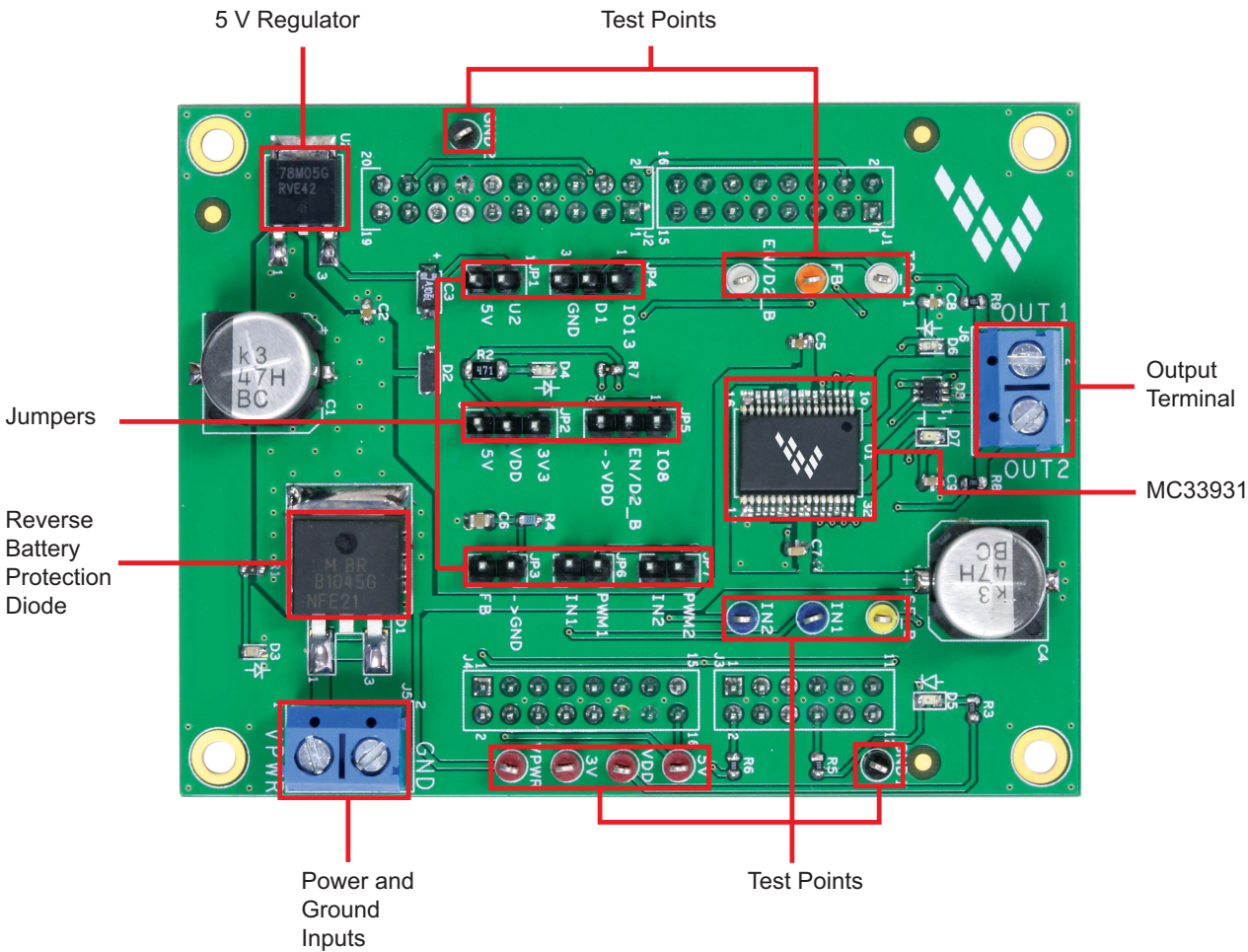

Figure 6. Board Description

Table 2. Board Description

Name	Description
MC33931	Monolithic H-Bridge Power IC in a robust thermally enhanced 32 pin SOIC-EP package
5.0 V Regulator	5.0 V regulator for VDD and supply
Jumpers	Jumpers for configuring the board for different modes of operation
Reverse Battery Protection Diode	Diode for protecting MC33931 in reverse battery condition
Power and Ground inputs	Power supply terminal to connect the battery/power supply with the board
Test Points	Test points to probe different signals
Output terminal	Output connector to connect a load to the MC33931 output

3.9 LED Display

The following LEDs are provided as visual output devices for the evaluation board:

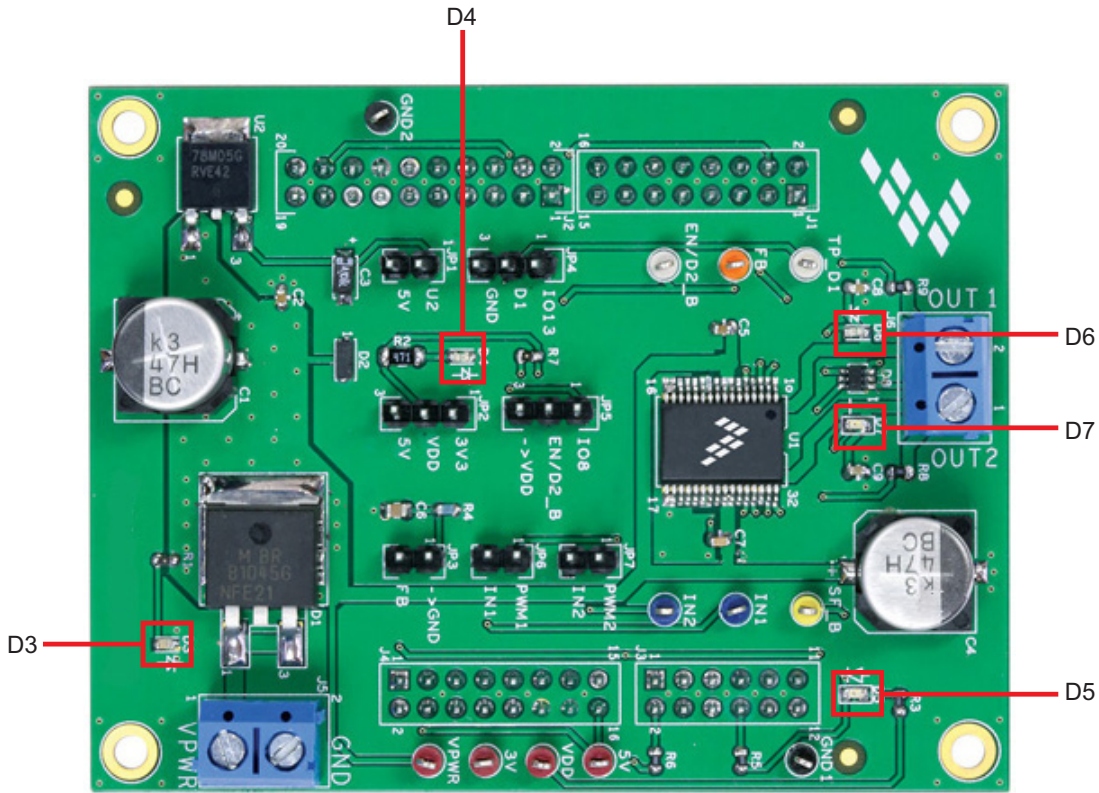

Figure 7. LED Display

Table 3. LED Display

LED ID	Description
D3	YELLOW LED, indicates when main/battery supply is connected
D4	GREEN LED, indicates when +5.0 V supply is connected
D5	RED LED, illuminates when the H-Bridge detects a fault
D6	GREEN LED, indicates current flowing in forward direction
D7	RED LED, indicates current flowing in reverse direction

3.10 Jumper Definitions

Figure 8 shows the jumper locations on the board.

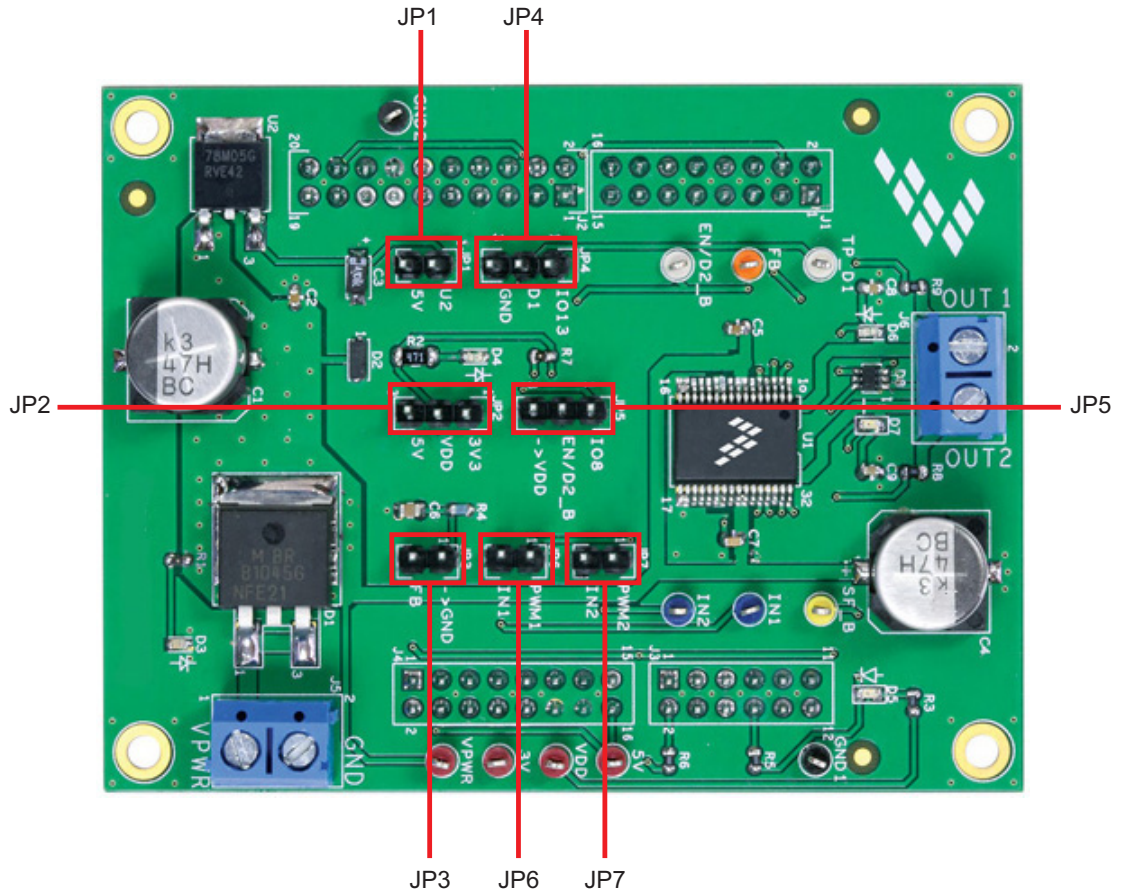

Figure 8. Board Jumpers

The following table defines the evaluation board jumper positions and explains their functions. (The default settings are shown in blue.)

Table 4. Jumper Definitions

Jumper	Description	Setting	Connection
JP1	5.0 V Regulator output	1-2	5.0 V regulator connected / External or USB 5.0 V
JP2	VDD Select	1-2	3.3 V as VDD
		2-3	5.0 V as VDD
JP3	FB	1-2	Feedback to MCU ADC / NC
JP4	D1	1-2	MCU GPIO
		2-3	GND
JP5	EN/D2_B	1-2	MCU GPIO
		2-3	VDD
JP6	IN1	1-2	MCU GPIO / EXT Signal to IN1
JP7	IN2	1-2	MCU GPIO / EXT Signal to IN2

3.11 Input Signal Definition

The board has the following input signals which are used to control the outputs or functions inside the circuit.

Table 5. Input Signals

Input Name	Description
D1	Disable signal to tri-state the outputs (Active High)
EN/D2_b	Disable signal to tri-state the output and put the part in sleep mode (Active Low)
IN1	Logic input to control OUT1
IN2	Logic input to control OUT2

3.12 Output Signal Definition

The board has the following output signals which are used to drive a load such as a brushed DC motor. It provides an analog output for real time load current monitoring. This signal allows closed loop control of the load.

Table 6. Output Signals

Output Name	Description
OUT1	Output 1 of H-Bridge controlled by the logic input IN1
OUT2	Output 2 of H-Bridge controlled by the logic input IN2
SF_B	Open drain Active Low status flag output to indicate fault
FB	Current mirror output for real time load current monitoring

3.13 Test Point Definition

Figure 9 shows the location of the test points on the board.

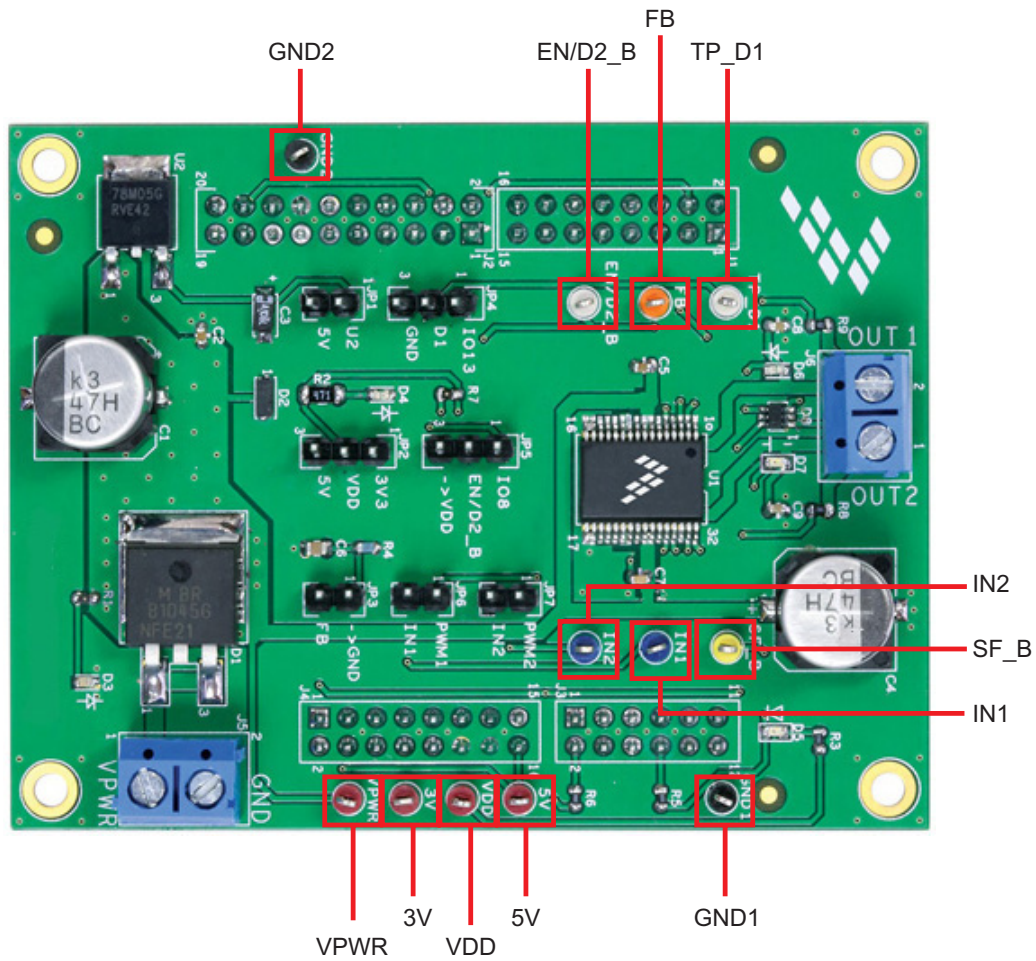

Figure 9. Test Points

The following test points provide access to various signals to and from the board.

Table 7. Test Points

Test Point Name	Signal Name	Description
TP_D1	D1	Disable signal to tri-state the outputs (Active High)
EN/D2_B	EN/D2_b	Disable signal to tri-state the output and put the part in sleep mode (Active Low)
FB	FB	Current mirror output for real time load current monitoring
IN1	IN1	Logic input to control OUT1
IN2	IN2	Logic input to control OUT2
SF_B	SF_b	Open drain Active Low status flag output to indicate fault
GND1	GND	Common Ground
GND2	GND	Common Ground
VPWR	VBAT	Battery or power supply input voltage
5V	5V	5.0 V signal from regulator

Table 7. Test Points (continued)

Test Point Name	Signal Name	Description
3V	3V3	3.3 V supply from the FRDM board
VDD	VDD	VDD supply for the FS_B pull-up resistor

3.14 Screw Terminal Connections

The board has following screw terminal connections to connect the power supply and the load. Figure 10 shows the location of the screw terminal connectors.

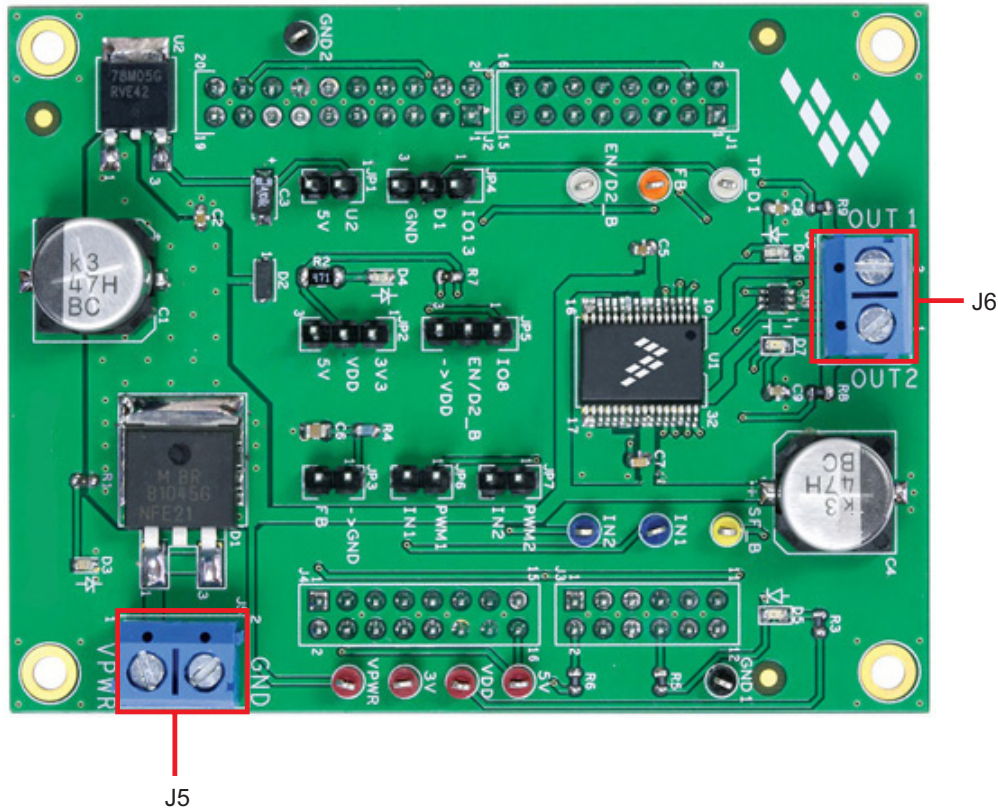

Figure 10. Screw Terminal Connectors

Table 8. Screw Terminal Connections

Screw Terminal Name	Description
J5	Power supply connector for MC33931
J6	Output connector for connecting to a load

4 FRDM-KL25Z Freedom Development Platform

The Freescale Freedom development platform is a set of software and hardware tools facilitating rapid prototyping of designs based on the Kinetis family of microcontrollers. The Freescale FRDM-KL25Z board serves as the basic hardware component of the development platform. The FRDM-KL25Z implements a Kinetis L Series microcontroller and makes use of the device's built-in USB, LED, and I/O port features. The board can be loaded with application specific firmware and can be configured with Graphical User Interface software that supports development and testing.

The Freescale FRDM-33931-EVB may be mounted to the FRDM-KL25Z as a shield board. When used in conjunction with the FRDM-33931-EVB, the FRDM-KL25Z provides basic functions, such as PC communication, that support the application-specific features of the evaluation board.

For use with the FRDM-33931-EVB, the FRDM-KL25Z must have ARM®mbed™ firmware installed (see [Section 5.2.2, Downloading mbed® Firmware to the FRDM-KL25Z Board](#)), MC33931 microcode installed (see [Section 5.2.3, Downloading the MC33931 Microcode to the FRDM-KL25Z Board](#)), and must use the Freescale “GUI Brushed DC FRDM-33931-EVB” as the software interface (see [Section 5.2.4, Installing the Graphical User Interface](#)).

For complete information on the FRDM-KL25Z, access the documentation available on the [FRDM-KL25Z Tool Summary](#) page.

Figure 11 illustrates the primary components of the FRDM-KL25Z that apply when 'used in conjunction with the evaluation board.

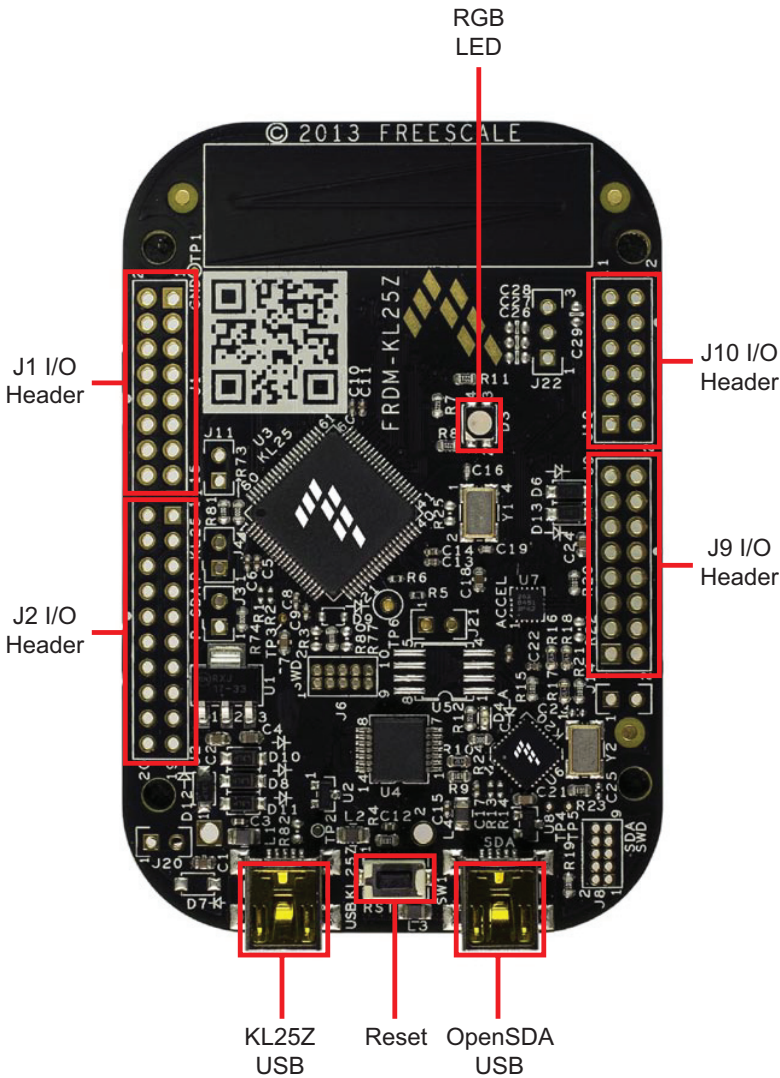

Figure 11. FRDM-KL25Z Board

4.1 Connecting the FRDM-KL25Z to the Evaluation Board

The FRDM-KL25Z development board provides an ideal support platform for the FRDM-33931-EVB kit. In this configuration, the FRDM-KL25Z connects to a PC and allows the user—via the GUI—to set parameters that control the operation of the motor. The FRDM-33931-EVB connects to the FRDM-KL25Z using the four dual row Arduino™ R3 connectors on the bottom of the board. The connections are as follows:

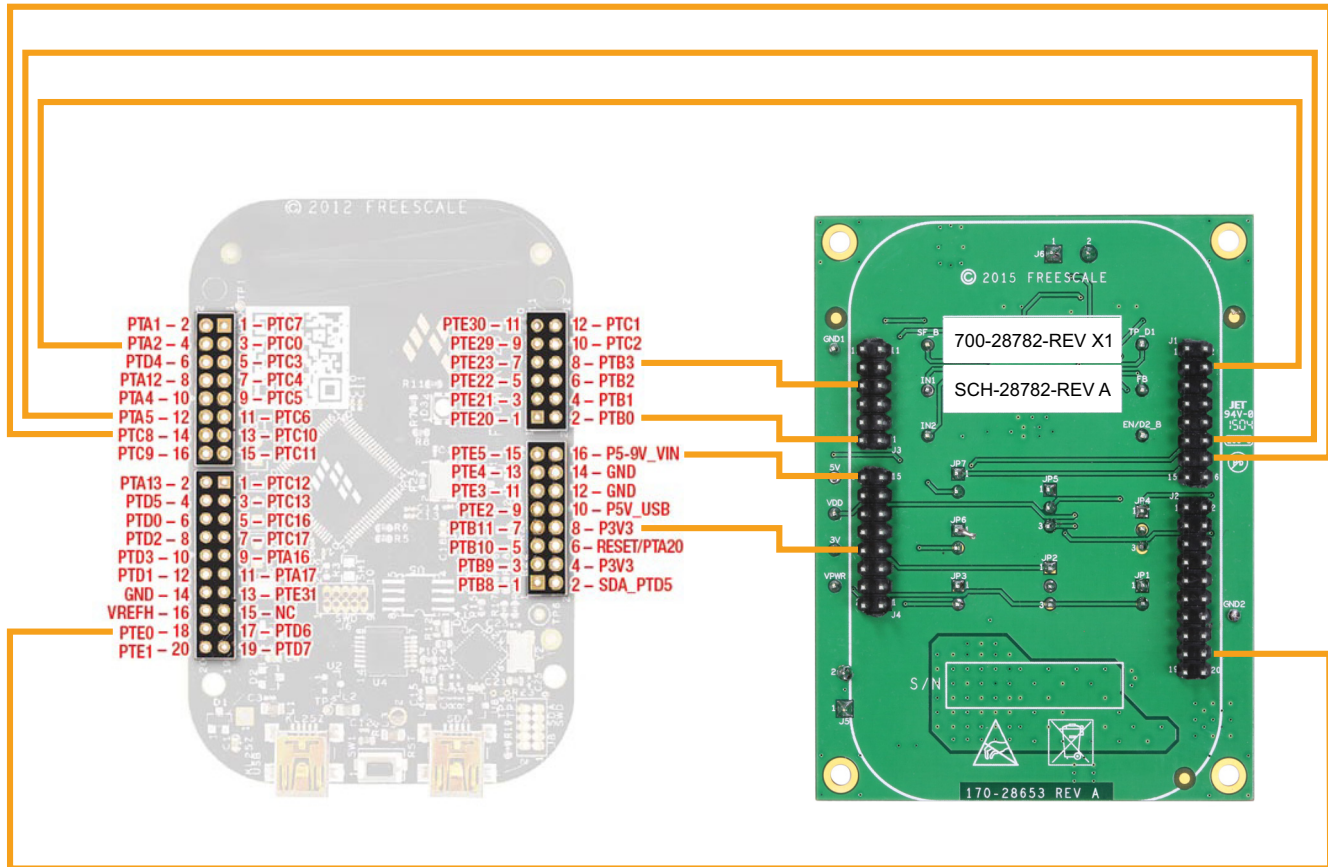

Figure 12. FRDM-KL25Z to FRDM-33931-EVB Connections

Table 9. FRDM-33931-EVB to FRDM-KL25Z Connections

FRDM-33931-EVB		FRDM-KL25Z		Pin Hardware Name		Description
Header	Pin	Header	Pin	FRDM-33931-EVB	FRDM-KL25Z	
J1	1	J1	1	N/C	PTC7	Not Connected
J1	2	J1	2	N/C	PTA1	Not Connected
J1	3	J1	3	N/C	PTC0	Not Connected
J1	4	J1	4	IO13 (D1)	PTA2	Disable signal to tri-state the outputs (Active High)
J1	5	J1	5	N/C	PTC3	Not Connected
J1	6	J1	6	N/C	PTD4	Not Connected
J1	7	J1	7	N/C	PTC4	Not Connected
J1	8	J1	8	N/C	PTA12	Not Connected

Table 9. FRDM-33931-EVB to FRDM-KL25Z Connections (continued)

FRDM-33931-EVB		FRDM-KL25Z		Pin Hardware Name		Description
Header	Pin	Header	Pin	FRDM-33931-EVB	FRDM-KL25Z	
J1	9	J1	9	N/C	PTC5	Not Connected
J1	10	J1	10	N/C	PTA4	Not Connected
J1	11	J1	11	N/C	PTC6	Not Connected
J1	12	J1	12	PWM1 (IN1)	PTA5	Logic input to control OUT1 using PWM signal
J1	13	J1	13	N/C	PTC10	Not Connected
J1	14	J1	14	PWM1 (IN2)	PTC8	Logic input to control OUT2 using PWM signal
J1	15	J1	15	N/C	PTC11	Not Connected
J1	16	J1	16	N/C	PTC9	Not Connected
J2	1	J2	1	N/C	PTC12	Not Connected
J2	2	J2	2	N/C	PTA13	Not Connected
J2	3	J2	3	N/C	PTC13	Not Connected
J2	4	J2	4	N/C	PTD5	Not Connected
J2	5	J2	5	N/C	PTC16	Not Connected
J2	6	J2	6	N/C	PTD0	Not Connected
J2	7	J2	7	N/C	PTC17	Not Connected
J2	8	J2	8	N/C	PTD2	Not Connected
J2	9	J2	9	N/C	PTA16	Not Connected
J2	10	J2	10	N/C	PTD3	Not Connected
J2	11	J2	11	N/C	PTA17	Not Connected
J2	12	J2	12	N/C	PTD1	Not Connected
J2	13	J2	13	N/C	PTE31	Not Connected
J2	14	J2	14	N/C	GND	Not Connected
J2	15	J2	15	N/C	N/C	Not Connected
J2	16	J2	16	N/C	VREFH	Not Connected
J2	17	J2	17	N/C	PTD6	Not Connected
J2	18	J2	18	IO8 (EN/D2_b)	PTE0	Disable signal to tri-state the output and put the part in Sleep mode (Active Low)
J2	19	J2	19	N/C	PTD7	Not Connected
J2	20	J2	20	N/C	PTE1	Not Connected
J3	1	J10	1	N/C	PTE20	Not Connected
J3	2	J10	2	FB	PTB0	Current mirror output for real time load current monitoring
J3	3	J10	3	N/C	PTE21	Not Connected
J3	4	J10	4	N/C	PTB1	Not Connected
J3	5	J10	5	N/C	PTE22	Not Connected
J3	6	J10	6	N/C	PTB2	Not Connected
J3	7	J10	7	N/C	PTE23	Not Connected

Table 9. FRDM-33931-EVB to FRDM-KL25Z Connections (continued)

FRDM-33931-EVB		FRDM-KL25Z		Pin Hardware Name		Description
Header	Pin	Header	Pin	FRDM-33931-EVB	FRDM-KL25Z	
J3	8	J10	8	SF_B	PTB3	Open drain Active Low status flag output to indicate fault
J3	9	J10	9	N/C	PTE29	Not Connected
J3	10	J10	10	N/C	PTC2	Not Connected
J3	11	J10	11	N/C	PTE30	Not Connected
J3	12	J10	12	N/C	PTC1	Not Connected
J4	1	J9	1	N/C	PTB8	Not Connected
J4	2	J9	2	N/C	SDA_PTD5	Not Connected
J4	3	J9	3	N/C	PTB9	Not Connected
J4	4	J9	4	N/C	P3V3	Not Connected
J4	5	J9	5	N/C	PTB10	Not Connected
J4	6	J9	6	N/C	RESET/PTA20	Not Connected
J4	7	J9	7	N/C	PTB11	Not Connected
J4	8	J9	8	FSD 3V3 OUT	P3V3	3.3 V logic output from FRDM-KL25Z board to FRDM34931S-EVB
J4	9	J9	9	N/C	PTE2	Not Connected
J4	10	J9	10	N/C	P5V_USB	Not Connected
J4	11	J9	11	N/C	PTE3	Not Connected
J4	12	J9	12	GND	GND	Not Connected
J4	13	J9	13	N/C	PTE4	Not Connected
J4	14	J9	14	N/C	GND	Not Connected
J4	15	J9	15	N/C	PTE5	Not Connected
J4	16	J9	16	FSD 5V IN	P5-9V_VIN	5.0 V logic input to FRDM-KL25Z board from FRDM-34931S-EVB

5 Setting up the Hardware and the Graphical User Interface (GUI)

The evaluation board is designed to work in conjunction with Freescale's FRDM-KL25Z board with the PC-based GUI providing direct access to the MC33931 MCU for testing and analysis. Alternatively, the board may be used as a stand-alone component, in which case lab hardware, such as a function generator, must be used to support testing and analysis.

The evaluation board consists of an H-bridge, a parallel interface, power conditioning circuitry, and a set of two Input Select jumpers. All +5.0 V V_{DD} power required by the board is obtained via the parallel interface.

Caution:

To avoid damaging the board, the following restrictions must be observed:

- The motor supply voltage (V_{PWR}) must be at least 5.0 V, but must not exceed 40 V.
- The peak operating current of the load must not exceed 5.0 A.

5.1 Setting up the FRDM-33931-EVB as a Stand-alone Component

This section describes how to configure the FRDM-33931-EVB for use as a stand-alone component. The procedure assumes that you are using a four-channel function generator to do testing and analysis. The same connections apply if the board is connected to a microcontroller instead of a function generator. Consult the board description ([Section 3](#)), the schematic ([Section 6](#)), and the MC33931 datasheet to determine how best to configure the board for use in your environment.

1. Connect the function generator to the board. There are two options:
 - use the function generator to control the enabling and disabling of the MC33931 H-bridge outputs (Option 1)
 - set the the H-bridge outputs to be continuously enabled while the board is connected to the function generator (Option 2).[Figure 13](#) illustrates how to set the jumpers and connect to a function generator (or an MCU) for each of these options.
2. With the power switched off, attach the DC power supply to the VPWR and GND screw connector terminals on the evaluation board (J5 in [Figure 10](#)).
3. Attach one set of coils of the brushed motor to the OUT 1 and OUT 2 screw connector terminals on the evaluation board (J6 in [Figure 10](#)).

[Figure 13](#) illustrates the hardware configuration.

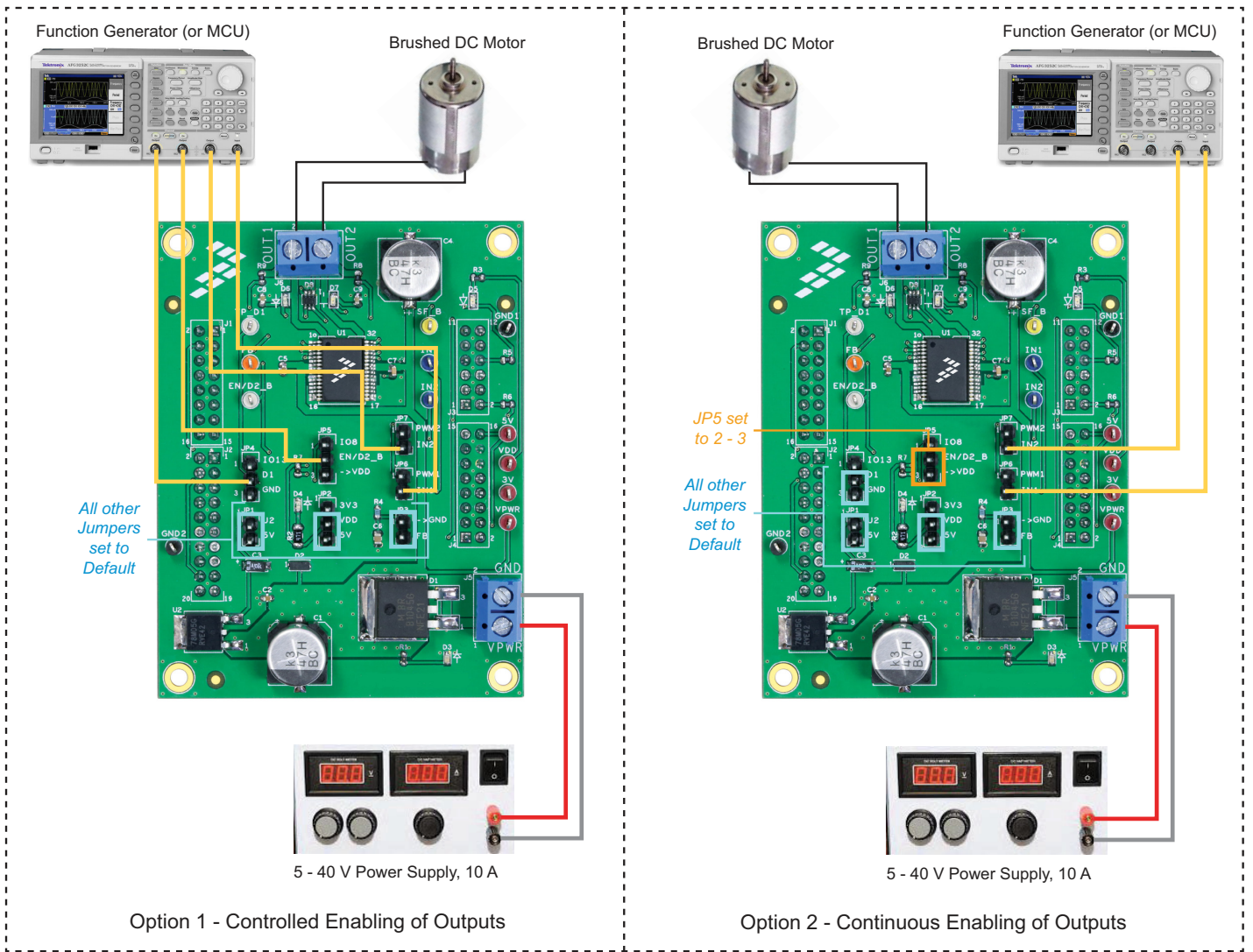

Figure 13. Hardware Configuration - Stand-alone

5.2 Setting up the FRDM-33931-EVB for Use with the FRDM-KL25Z

To configure the evaluation board for use with the FRDM KL25Z and the Graphical User Interface (GUI) you must:

- Connect the hardware
- Download the mbed firmware to the FRDM-KL25Z board
- Download the MC33931 microcode to the FRDM-KL25Z board
- Install the Graphical User Interface “GUI Brushed DC FRDM-33931-EVB”

5.2.1 Connecting the Hardware

The FRDM-33931-EVB consists of an H-bridge, a parallel interface, power conditioning circuitry, and a set of two Input Select jumpers. All +5.0 V V_{DD} power required by the board is obtained via the parallel interface.

WARNING

To avoid damaging the board, the following restrictions must be observed:

- The motor supply voltage (V_{PWR}) must be at least 5.0 V, but must not exceed 40 V.
- The peak operating current of the load must not exceed 5.0 A.

1. Connect the FRDM-33931-EVB to the FRDM-KL25Z.
2. With the power switched off, attach the DC power supply to the VPWR and GND screw connector terminals on the evaluation board (J5 in Figure 10).
3. Attach one set of coils of the brushed motor to the OUT 1 and OUT 2 screw connector terminals on the evaluation board (J6 in Figure 10).

Figure 14 illustrates the hardware configuration.

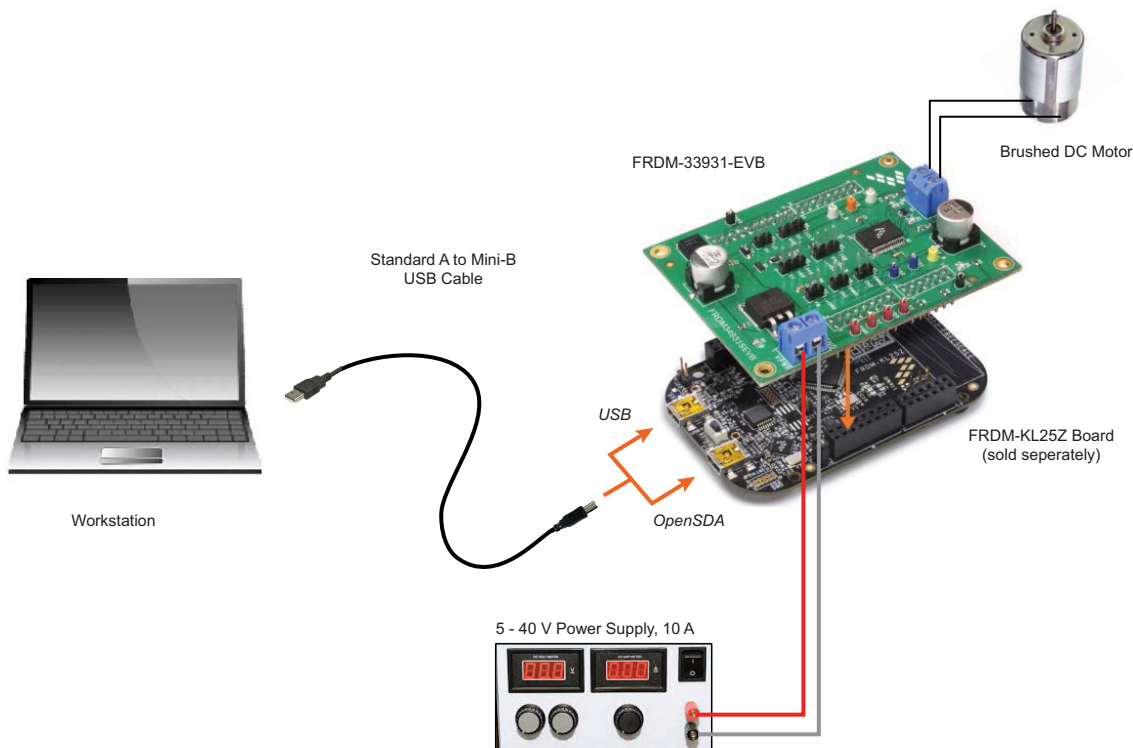

Figure 14. FRDM-33931-EVB with FRDM-KL25Z Hardware Configuration

5.2.2 Downloading mbed® Firmware to the FRDM-KL25Z Board

You must install mbed® firmware on the FRDM-KL25Z board to enable downloading of the MC33931 microcode. The procedure is as follows:

1. Connect the USB cable between your PC and the OpenSDA port on the FRDM-KL25Z board.
2. Download the mbed firmware onto the FRDM-KL25Z board. The instructions are on the ARM®mbed™ website at the following url: <https://developer.mbed.org/handbook/Firmware-FRDM-KL25Z>
3. After downloading the mbed firmware, power cycle the board (by disconnecting then reconnecting the USB cable to the OpenSDA port) to initiate the firmware update. When this process completes, a USB drive named “mbed” should appear on your PC.

5.2.3 Downloading the MC33931 Microcode to the FRDM-KL25Z Board

The MC33931 microcode provides the firmware interface between the MC33931 device, the Freedom platform and the GUI. The procedure is as follows:

1. Connect the USB cable between your PC and the OpenSDA port on the FRDM-KL25Z board.
2. Go to https://developer.mbed.org/teams/Freescale/code/Brushed_DC_Motor_Control_MC34931_MC33931/ then click on the Import this Program tab.

1. Go to:
developer.mbed.org/teams/Freescale/code/Brushed_DC_Motor_Control_MC34931_MC33931/

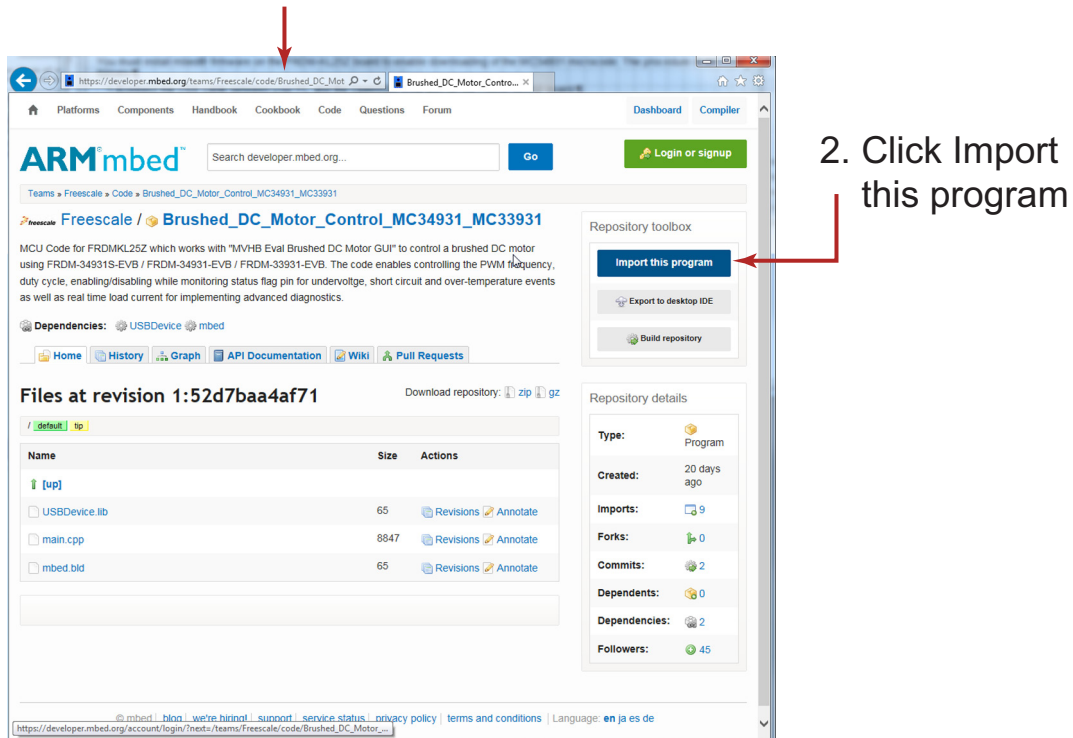

Figure 15. MC33931/MC33931 mbed Import Screen

3. Login to your mbed account. (If you do not have an mbed account, you must create one.) After logging in, you will be returned to the screen in Figure 15. Click on Import this program again.

1. Enter your Username and Password

2. Click Login

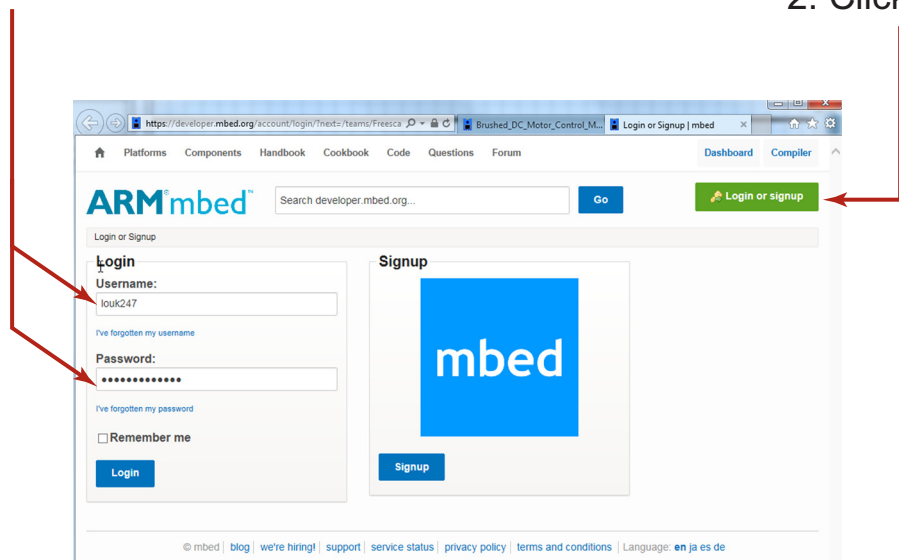

Figure 16. mbed Login Screen

4. The mbed compiler opens with the Import Program window displayed. Click on the "Import" button.

1. Click Import

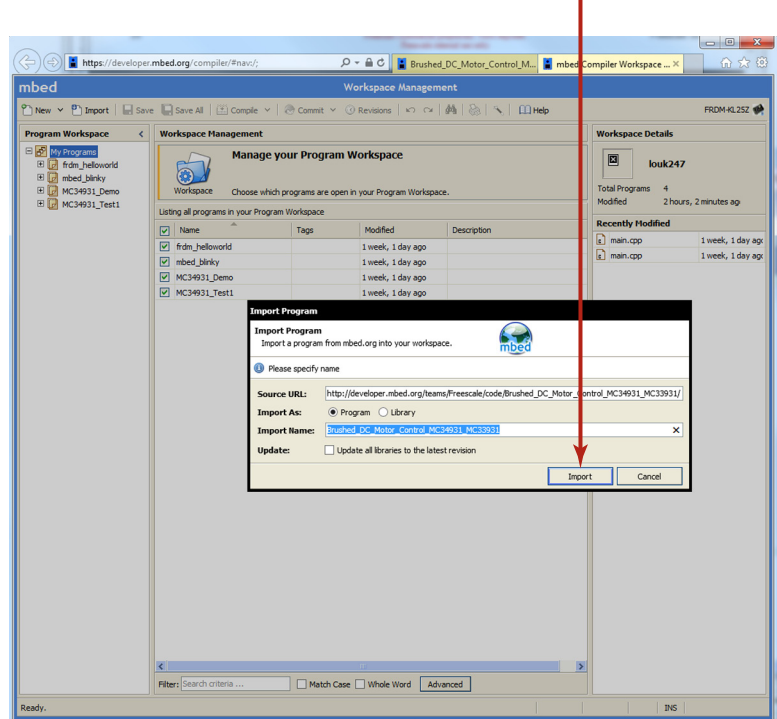
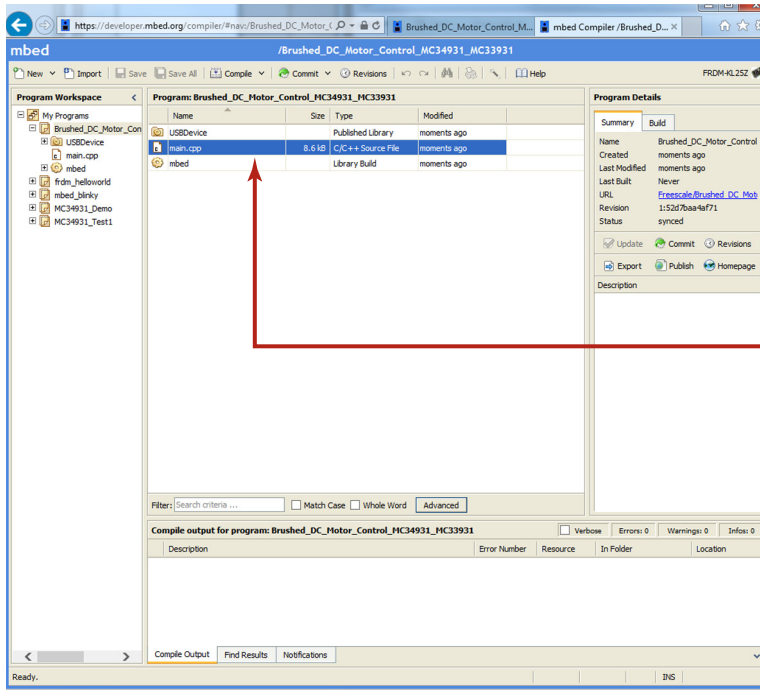

Figure 17. mbed Compiler Import Program Screen

5. When the import completes, the mbed compiler screen should look like [Figure 18](#). Click on the “main.cpp” item.



1. Click on main.cpp

Figure 18. mbed Compiler Select Screen

6. The source code for main.cpp appears in the code editor. Click on the “Compile” button to compile the main.cpp source code.

1. Click on Compile

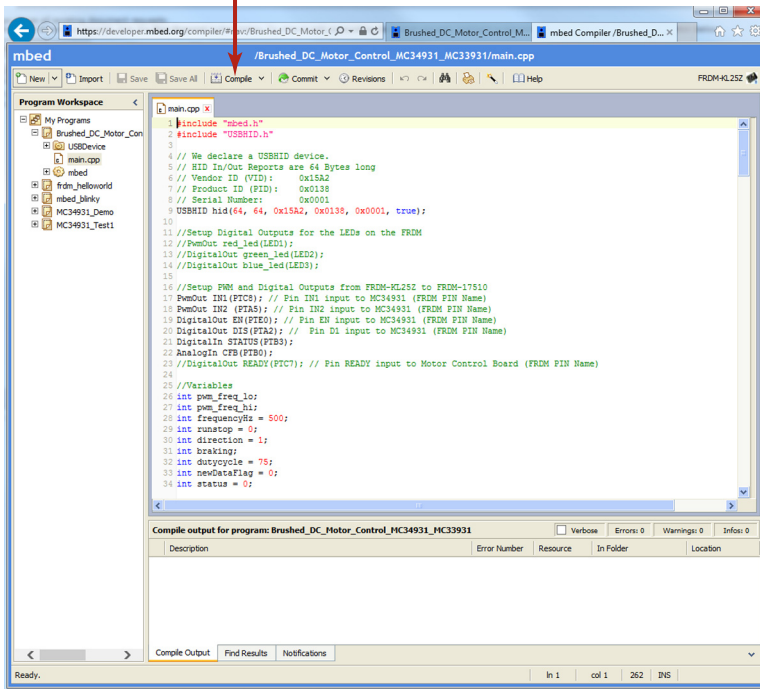

Figure 19. mbed Compiler New Program Screen

- When the compiler completes, an executable file named “Brushed_DC_Motor_Control_MC33931_MC33931_KL25Z.bin” downloads to your system download folder. Drag and drop this file to the mbed device which appears as a USB drive on your system.

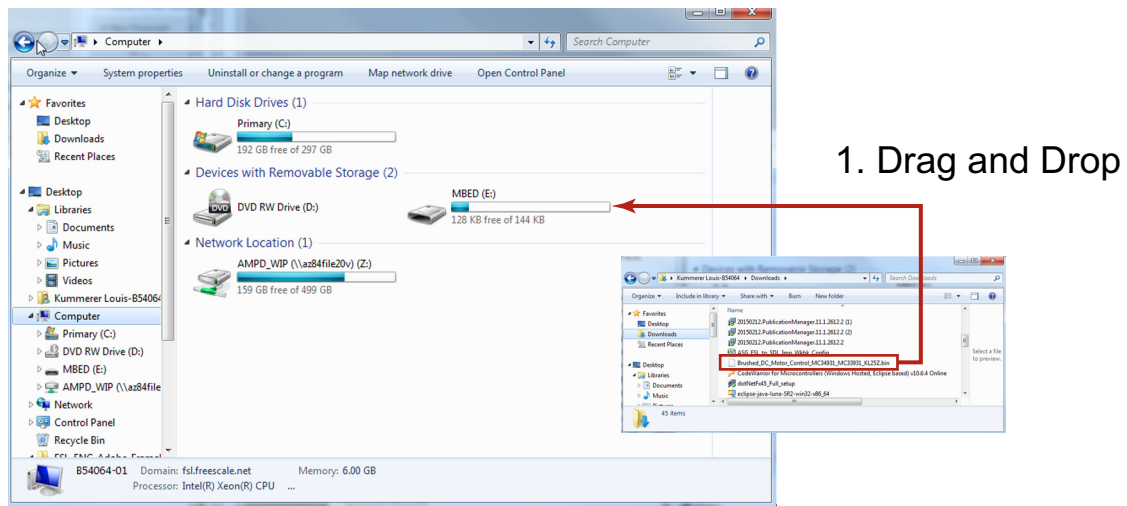

Figure 20. Downloading Brushed_DC_Motor_Control_MC33931_KL25Z.bin to FRDM-KL25Z

- Remove the USB connector from the FRDM-KL25Z OpenSDA USB port and insert it in the KL25Z USB port. The KL25Z board is now ready for use with the FRDM-33931S-EVB and the GUI.

5.2.4 Installing the Graphical User Interface

The Graphical User Interface provides a PC-based interface allowing you to easily exercise FRDM-33931-EVB functions to control a DC Brushed Motor. The GUI runs on any Windows 8, Windows 7, Vista, or XP-based operating system at a maximum PWM frequency of 10 KHZ.

To install the software:

- Go to the evaluation board Tool Summary Page www.freescale.com/FRDM-33931-EVB
- Under “Jump Start Your Design,” click on the “Get Started with the FRDM-33931-EVB” link.
- From the list of files that appear, click on the link for the “GUI Brushed DC FRDM-33931-EVB” software.

The software automatically downloads to your PC and initiates the installation process. An Installation Wizard guides you through the rest of the process.

5.2.5 Using the Graphical User Interface

To start the GUI, do the following:

- Connect the hardware ([Section 5.2.1, Connecting the Hardware](#)) and plug the USB cable into the USB port on the FRDM-KL25Z.
- Click on the Freescale GUI Brushed DC FRDM-33931-EVB icon to launch the GUI.
- Make sure the GUI recognizes the FRDM-KL25Z. Check the USB connection in the upper left corner of the GUI.
 - The hex Vendor ID value should display as 0x15A2 and the Part ID value should display as 0x138.
 - If these value do not appear, the GUI has failed to establish a connection with the FRDM-KL25Z. You may need to disconnect and reconnect the USB cable to the board’s KL25Z USB port. If the connection still fails, press the reset button on the FRDM-KL25Z board.
- Click the Enable Target checkbox on the GUI screen. The Target parameter on the GUI screen should change from “DISABLED” to “ENABLED.”

5. Set the DI, EN/D2_B, Direction and Braking as desired (See [Section 5.2.6](#) - [Section 5.2.9](#).) Adjust the PWM Frequency and Duty Cycle to meet your requirements.
6. Click the Run button to run the motor. Notice that some options of the GUI are disabled while the motor is running. To make changes, click the Stop button on the GUI, make the desired changes, and then click “Run” on the GUI to continue.
7. When finished, deselect the “Enable Target” button on the GUI, and click the Quit button. Turn off DC power supply and remove the USB cable.

The GUI is shown in [Figure 21](#). The hex address numbers at the top are loaded with the vendor ID for Freescale (0x15A2), and the part ID (0x138). The left side panel displays these numbers only if the PC is communicating with the FRDM-KL25Z via the USB interface.

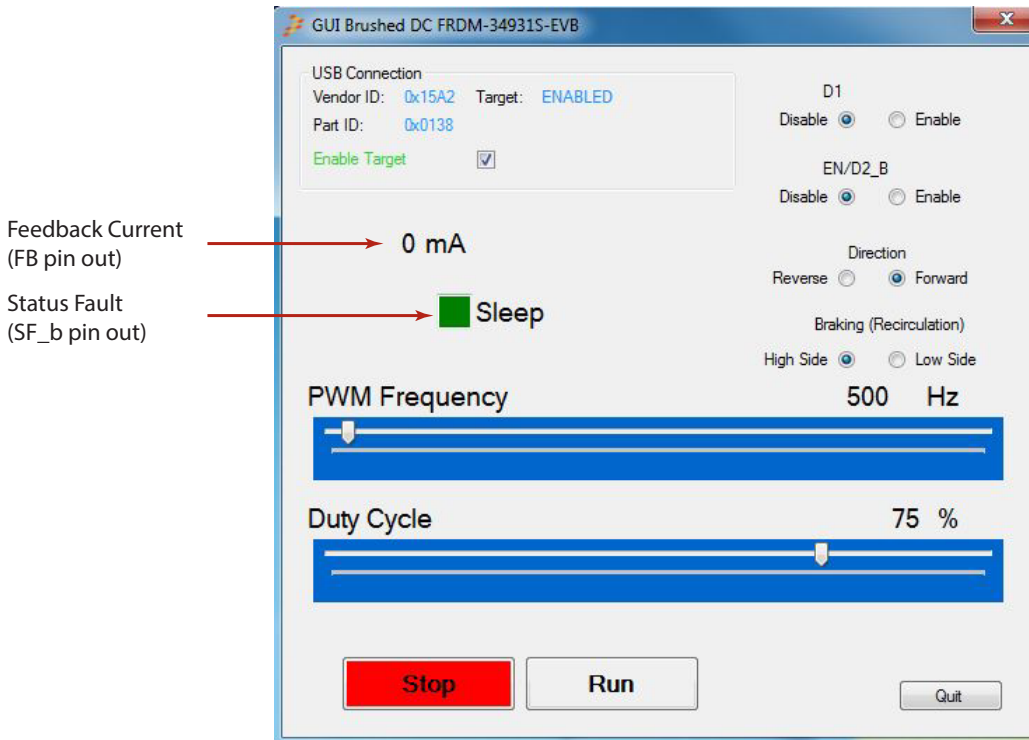

Figure 21. GUI Screen

5.2.6 Forward with High-side Recirculation

To test the FRDM-33931-EVB in the forward with high-side recirculation mode, configure the GUI as follows:

- D1: Enable
- EN/D2_B: Enable
- Direction: Forward
- Braking: High-side

Figure 22 shows this configuration with the motor running.

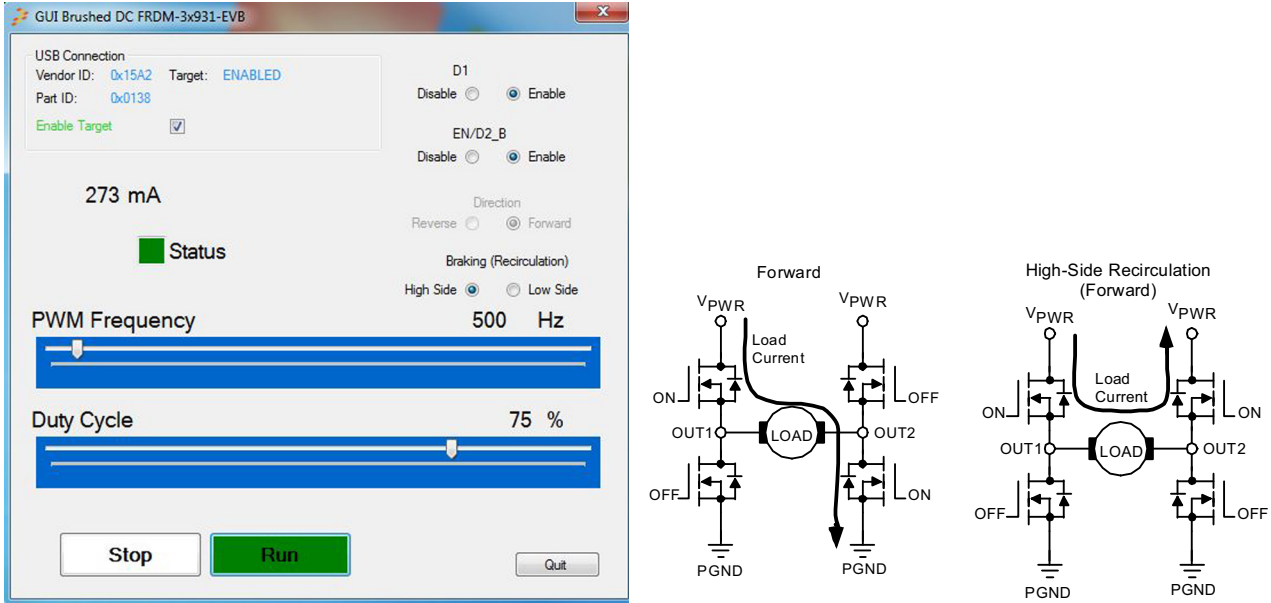

Figure 22. Forward with High-side Recirculation

5.2.7 Forward with Low-side Recirculation

To test the FRDM-33931-EVB in the forward with low-side recirculation mode, configure the GUI as follows:

- D1: Enable
- EN/D2_B: Enable
- Direction: Forward
- Braking: Low-side

Figure 23 shows this configuration with the motor running.

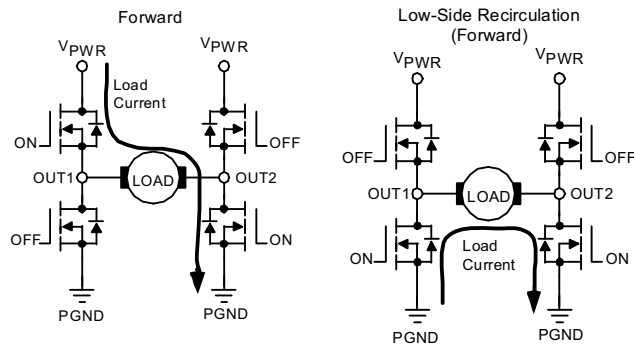
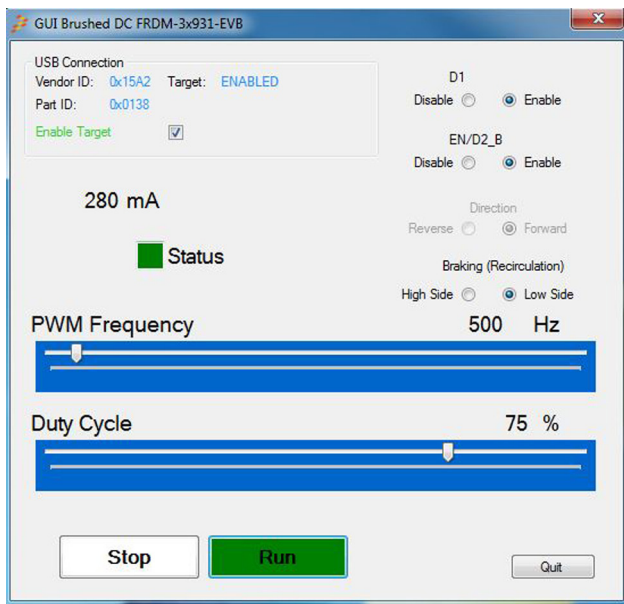

Figure 23. Forward with Low-side Recirculation

5.2.8 Reverse with High-side Recirculation

To test the FRDM-33931-EVB in the reverse with high-side recirculation mode, configure the GUI as follows:

- D1: Enable
- EN/D2_B: Enable
- Direction: Reverse
- Braking: High-side

Figure 24 shows this configuration with the motor running.

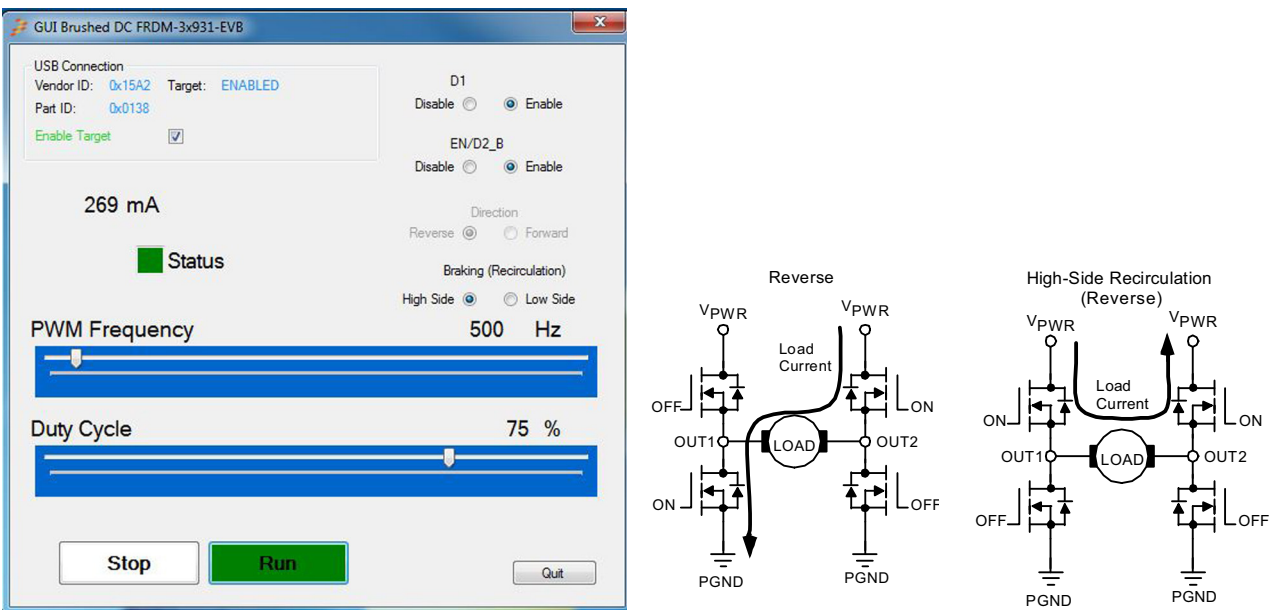

Figure 24. Reverse with High-side Recirculation

5.2.9 Reverse with Low-side Recirculation

To test the FRDM-33931-EVB in the reverse with low-side recirculation mode, configure the GUI as follows:

- D1: Enable
- EN/D2_B: Enable
- Direction: Reverse
- Braking: Low-side

Figure 25 shows this configuration with the motor running.

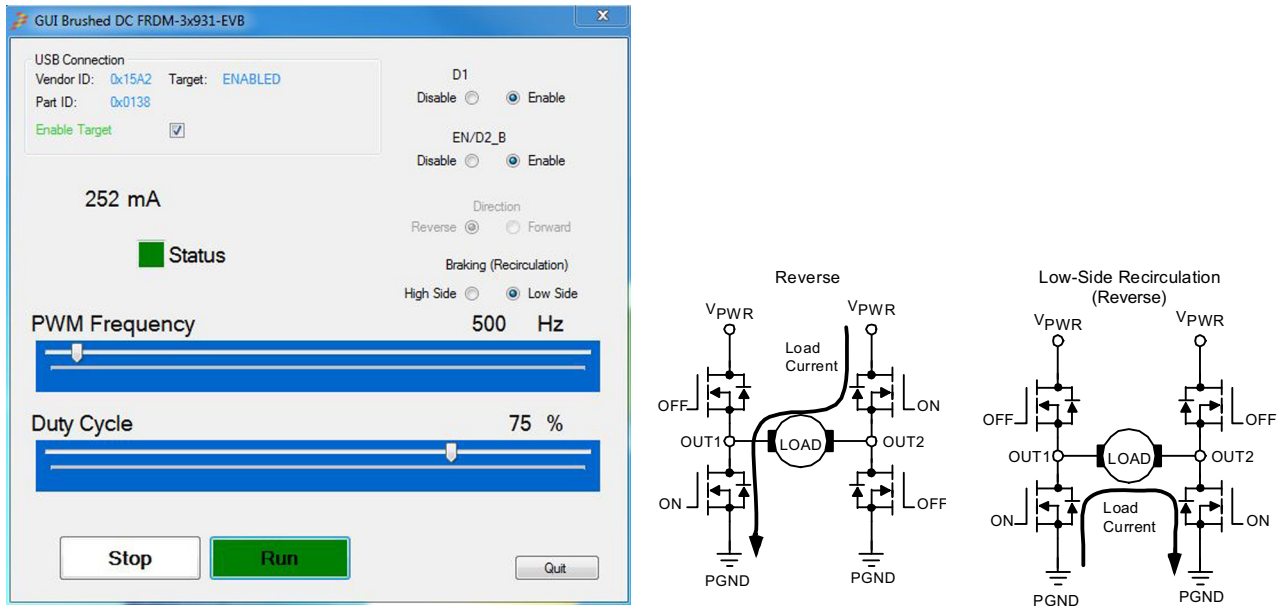

Figure 25. Reverse with Low-side recirculation

5.2.10 Direction Control with High-side vs. Low-side Recirculation

Table 10 illustrates the logic behind direction control with high-side versus low-side recirculation.

Table 10. H-Bridge Operation Logic

1	Forward - High-side recirculation
	IN1 = 1 IN2 = PWM signal with selected duty cycle and frequency
2	Reverse - High-side recirculation
	IN1 = 0 IN2 = PWM signal with selected duty cycle and frequency
3	Forward - Low-side recirculation
	IN1 = PWM signal with selected duty cycle frequency IN2 = 0
4	Reverse - Low-side recirculation
	IN1 = 0 IN2 = PWM signal with selected duty cycle

6 Schematic

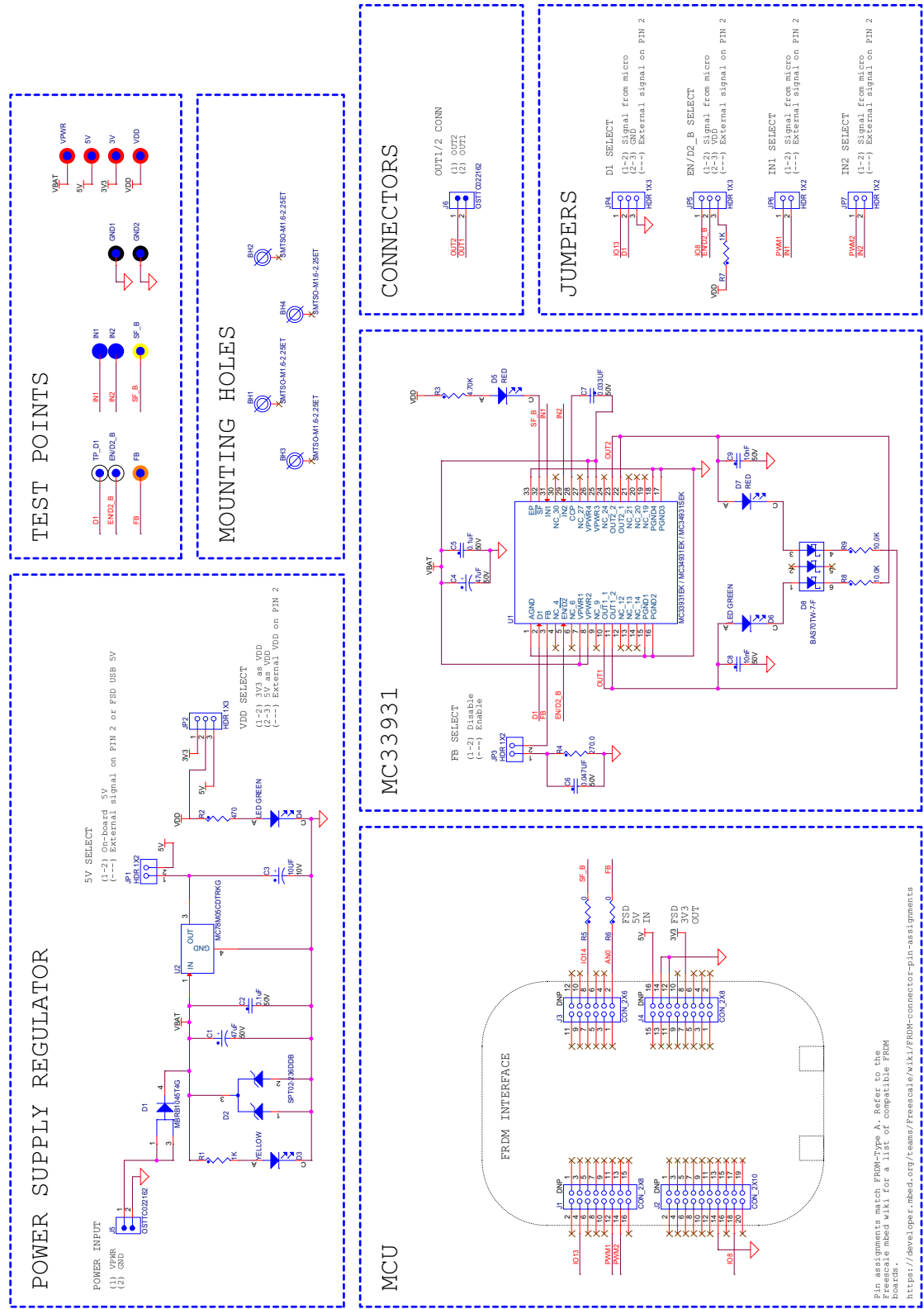

Figure 26. Schematic

7 Board Layout

7.1 Silkscreen

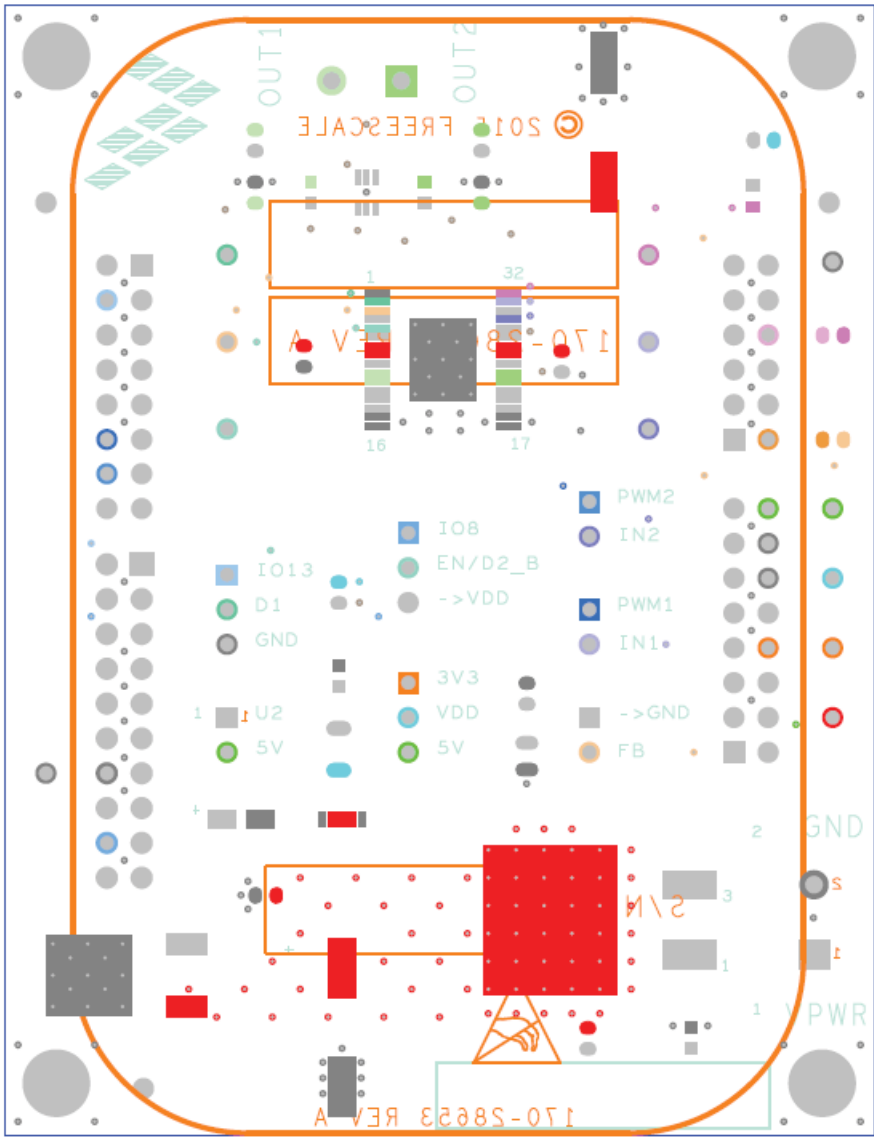

Figure 27. Silkscreen

8 Board Bill of Materials

 Table 11. Bill of Materials ⁽¹⁾

Item	Qty	Schematic Label	Value	Description	Part Number	Assy Opt
Freescale Components						
1	1	U1		Freescale device	MC33931	(2)
Voltage Regulator						
2	1	U2		IC LIN VREG LDO 5 V 0.5 A 35 V DPAK	MC78M05CDTRKG	
Diodes						
3	1	D1		DIODE SCH PWR RECT 10 A 45 V D2PAK	MBRB1045T4G	
4	1	D2		DIODE DUAL ARRAY 2 A 6-36 V uQFN-2L	SPT02-236DDB	
5	1	D3		LED YEL SGL 25 MA SMT 0603	LY Q976-P1S2-36-0-20-R18	
6	2	D4, D6		LED GRN SGL 20 MA 0603	LG L29K-G2J1-24-Z	
7	2	D5, D7		LED SM RED 0603 ROHS COMPLIANT	QTLP600CRTR	
8	1	D8		DIODE SCH TRIPLE 70 MA 70 V / 200 MW SOT363	BAS70TW-7	
Capacitors						
9	2	C1, C4	47 μ F	CAP ALEL 47 μ F 50 V 20% AUTO SMD	UBC1H470MNS1GS	
10	2	C2, C5	0.1 μ F	CAP CER 0.1 μ F 50 V 5% X7R AEC-Q200 0603	C0603C104J5RACAUTO	
11	1	C3	10 μ F	CAP TANT 10 μ F 10 V 10% — 3216-18	293D106X9010A2TE31	
12	1	C6	0.047 μ F	CAP CER 0.047 μ F 50 V 5% X7R 0805	C0805C473J5RAC	
13	1	C7	0.033 μ F	CAP CER 0.033 μ F 50 V 5% X7R 0603	06035C333JAT2A	
14	2	C8, C9	0.1 μ F	CAP CER 0.01 μ F 50 V 5% X7R 0603	06035C103JAT2A	
Resistors						
15	2	R1, R7	1.0 K Ω	RES -- 1 K Ω 1/4 W 1% AEC-Q200 0603 ANTISURGE	ESR03EZPF1001	
16	1	R2	470 Ω	RES MF 470 Ω 1/4 W 5% AEC-Q200 1206	CRCW1206470RJNEA	
17	1	R3	4.7 K Ω	RES MF 4.7 K Ω 1/4 W 1% AEC-Q200 0603	CRCW06034K70FKEA	
18	1	R4	270 Ω	RES MF 270.0 Ω 1/10 W 1% 0603	RK73H1JTDD2700F	
19	2	R5, R6	0 Ω	RES MF ZERO Ω 1/10 W — AEC-Q200 0603	RK73Z1JTDD	
20	1	R8, R9	10 K Ω	RES MF 10.0 K Ω 1/10 W 1% 0603	RK73H1JTDD1002F	

Table 11. Bill of Materials ⁽¹⁾ (continued)

Item	Qty	Schematic Label	Value	Description	Part Number	Assy Opt
Switches, Connectors, Jumpers and Test Points						
21	12	TP_D1,EN/D2_B, FB, GND1,GND2, IN1,IN2, SF_B, 3V,5V,VPWR,VDD		TEST POINT 40 MIL DRILL 180 MIL		
22	4	JP1,JP3,JP6,JP7		HDR 1X2 TH 100 MIL SP 338H SN 100L	TSW-102-07-T-S	
23	3	JP2,JP4,JP5		HDR 1x3 TH 100 MIL SP 343H SN 100L	TSW-103-07-T-S	
24	2	J1, J4		HDR 2X8 TH 100MIL CTR 338H SN 100L	TSW-108-07-T-D	
25	1	J2		HDR 2X10 TH 100MIL CTR 343H SN 100L	TSW-110-07-T-D	
26	1	J3		HDR 2X6 TH 100MIL CTR 338H SN 100L	TSW-106-07-T-D	
27	2	J5, J6		CON 1X2 TB 5.08 MM SP 406H SN 138L	OSTTC022162	

Notes

1. Freescale does not assume liability, endorse, or warrant components from external manufacturers are referenced in circuit drawings or tables. While Freescale offers component recommendations in this configuration, it is the customer's responsibility to validate their application.
2. **Critical components.** For critical components, it is vital to use the manufacturer listed.

9 Accessory Item Bill of Materials

Table 12. Bill of Materials ⁽³⁾

Item	Qty	Part Number	Description
1	1	FRDM-KL25Z	Freescale Freedom Development Platform for Kinetis KL14/15/24/25 MCUs

Notes

3. Freescale does not assume liability, endorse, or warrant components from external manufacturers are referenced in circuit drawings or tables. While Freescale offers component recommendations in this configuration, it is the customer's responsibility to validate their application.

10 References

Following are URLs where you can obtain information on related Freescale products and application solutions:

Freescale.com Support Pages	Description	URL
FRDM-33931-EVB	Tool Summary Page	http://www.freescale.com/webapp/sps/site/prod_summary.jsp?code=FRDM-33931-EVB
MC33931	Product Summary Page	http://www.freescale.com/webapp/sps/site/prod_summary.jsp?code=MC33931
FRDM-KL25Z	Tool Summary Page	http://www.freescale.com/webapp/sps/site/prod_summary.jsp?code=FRDM-KL25Z
ARM@mbed™	mbed FRDM-KL25Z Upgrade Page	https://mbed.org/handbook/mbed-FRDM-KL25z-Upgrade

10.1 Support

Visit www.freescale.com/support for a list of phone numbers within your region.

10.2 Warranty

Visit www.freescale.com/warranty to submit a request for tool warranty.

11 Revision History

Revision	Date	Description of Changes
1.0	7/2015	• Initial Release

How to Reach Us:

Home Page:
freescale.com

Web Support:
freescale.com/support

Information in this document is provided solely to enable system and software implementers to use Freescale products. There are no express or implied copyright licenses granted hereunder to design or fabricate any integrated circuits based on the information in this document.

Freescale reserves the right to make changes without further notice to any products herein. Freescale makes no warranty, representation, or guarantee regarding the suitability of its products for any particular purpose, nor does Freescale assume any liability arising out of the application or use of any product or circuit, and specifically disclaims any and all liability, including without limitation consequential or incidental damages. "Typical" parameters that may be provided in Freescale data sheets and/or specifications can and do vary in different applications, and actual performance may vary over time. All operating parameters, including "typicals," must be validated for each customer application by customer's technical experts. Freescale does not convey any license under its patent rights nor the rights of others. Freescale sells products pursuant to standard terms and conditions of sale, which can be found at the following address: freescale.com/SalesTermsandConditions.

Freescale, the Freescale logo and Kinetis are trademarks of Freescale Semiconductor, Inc., Reg. U.S. Pat. & Tm. Off. SMARTMOS is a trademarks of Freescale Semiconductor, Inc. All other product or service names are the property of their respective owners. ARM is a registered trademark of ARM Limited (or its subsidiaries) in the EU and/or elsewhere. mbed is a trademark of ARM Limited (or its subsidiaries) in the EU and/or elsewhere. All rights reserved.

© 2015 Freescale Semiconductor, Inc.

Document Number: KTFRDM33931UG
Rev. 1.0
7/2015