

Apr.1.2017 Copyright 2017 HIROSE ELECTRIC CO., LTD. All Rights Reserved.

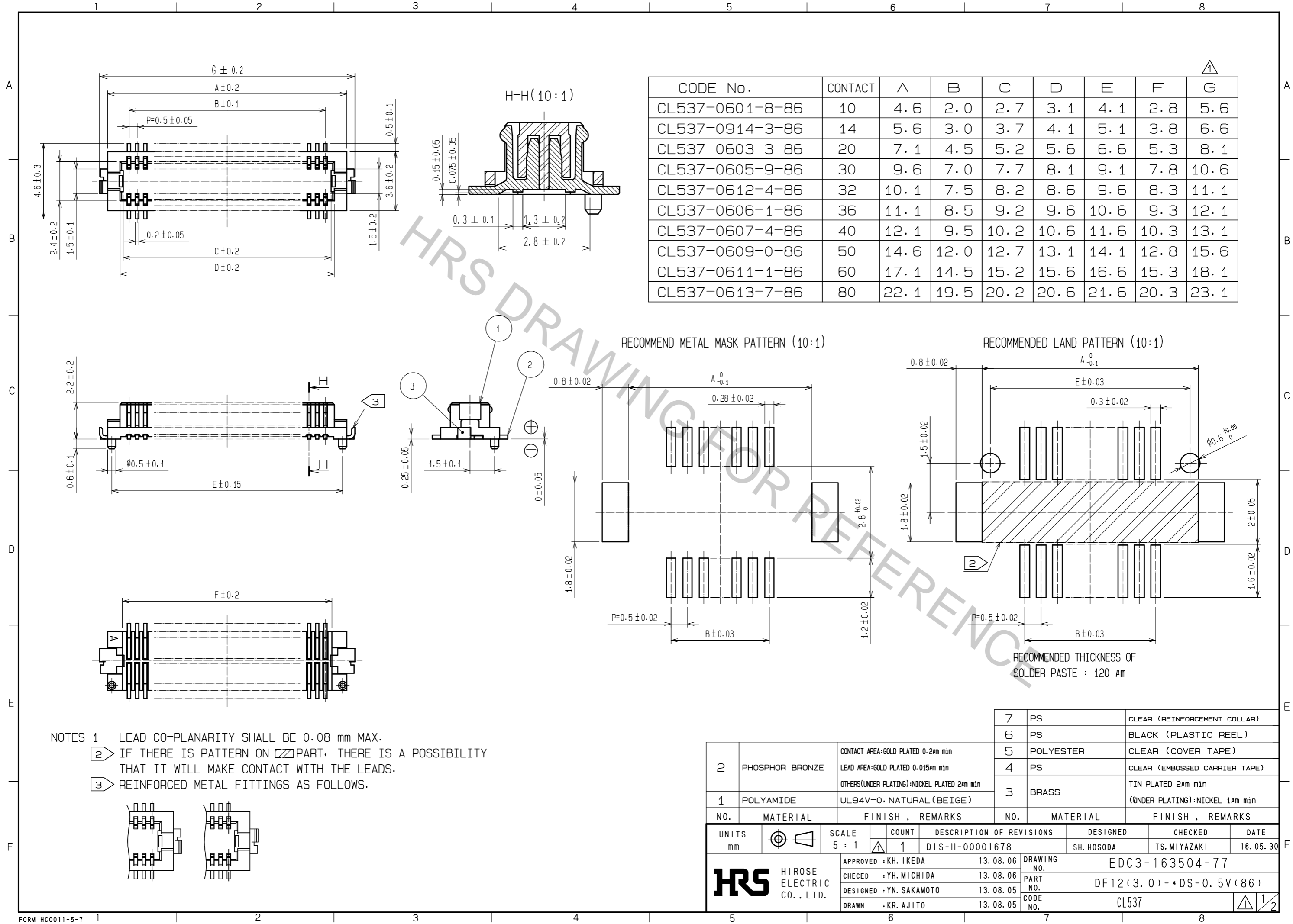

CODE No.	CONTACT	A	B	C	D	E	F	G
CL537-0601-8-86	10	4.6	2.0	2.7	3.1	4.1	2.8	5.6
CL537-0914-3-86	14	5.6	3.0	3.7	4.1	5.1	3.8	6.6
CL537-0603-3-86	20	7.1	4.5	5.2	5.6	6.6	5.3	8.1
CL537-0605-9-86	30	9.6	7.0	7.7	8.1	9.1	7.8	10.6
CL537-0612-4-86	32	10.1	7.5	8.2	8.6	9.6	8.3	11.1
CL537-0606-1-86	36	11.1	8.5	9.2	9.6	10.6	9.3	12.1
CL537-0607-4-86	40	12.1	9.5	10.2	10.6	11.6	10.3	13.1
CL537-0609-0-86	50	14.6	12.0	12.7	13.1	14.1	12.8	15.6
CL537-0611-1-86	60	17.1	14.5	15.2	15.6	16.6	15.3	18.1
CL537-0613-7-86	80	22.1	19.5	20.2	20.6	21.6	20.3	23.1

RECOMMEND METAL MASK PATTERN (10:1)

RECOMMENDED LAND PATTERN (10:1)

RECOMMENDED THICKNESS OF SOLDER PASTE : 120 μm

- NOTES
- LEAD CO-PLANARITY SHALL BE 0.08 mm MAX.
 - IF THERE IS PATTERN ON PART, THERE IS A POSSIBILITY THAT IT WILL MAKE CONTACT WITH THE LEADS.
 - REINFORCED METAL FITTINGS AS FOLLOWS.

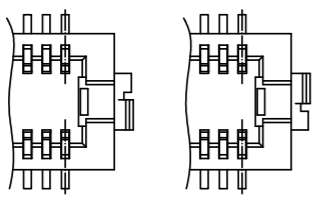

NO.	MATERIAL	FINISH .	REMARKS	NO.	MATERIAL	FINISH .	REMARKS
2	PHOSPHOR BRONZE		CONTACT AREA:GOLD PLATED 0.2μm min LEAD AREA:GOLD PLATED 0.015μm min OTHERS(UNDER PLATING):NICKEL PLATED 2μm min	7	PS		CLEAR (REINFORCEMENT COLLAR)
1	POLYAMIDE		UL94V-0, NATURAL (BEIGE)	6	PS		BLACK (PLASTIC REEL)
				5	POLYESTER		CLEAR (COVER TAPE)
				4	PS		CLEAR (EMBOSSED CARRIER TAPE)
				3	BRASS		TIN PLATED 2μm min (UNDER PLATING):NICKEL 1μm min

UNITS	SCALE	COUNT	DESCRIPTION OF REVISIONS	DESIGNED	CHECKED	DATE
mm	5 : 1	1	DIS-H-00001678	SH. HOSODA	TS. MIYAZAKI	16. 05. 30

APPROVED	CHECED	DESIGNED	DRAWN	DATE	DRAWING NO.	PART NO.	CODE NO.
KH. IKEDA	YH. MICHIDA	YN. SAKAMOTO	KR. AJITO	13. 08. 06	EDC3-163504-77	DF12(3.0)-*DS-0.5V(86)	CL537

STYLE AND DIMENTION OF REEL (FREE)

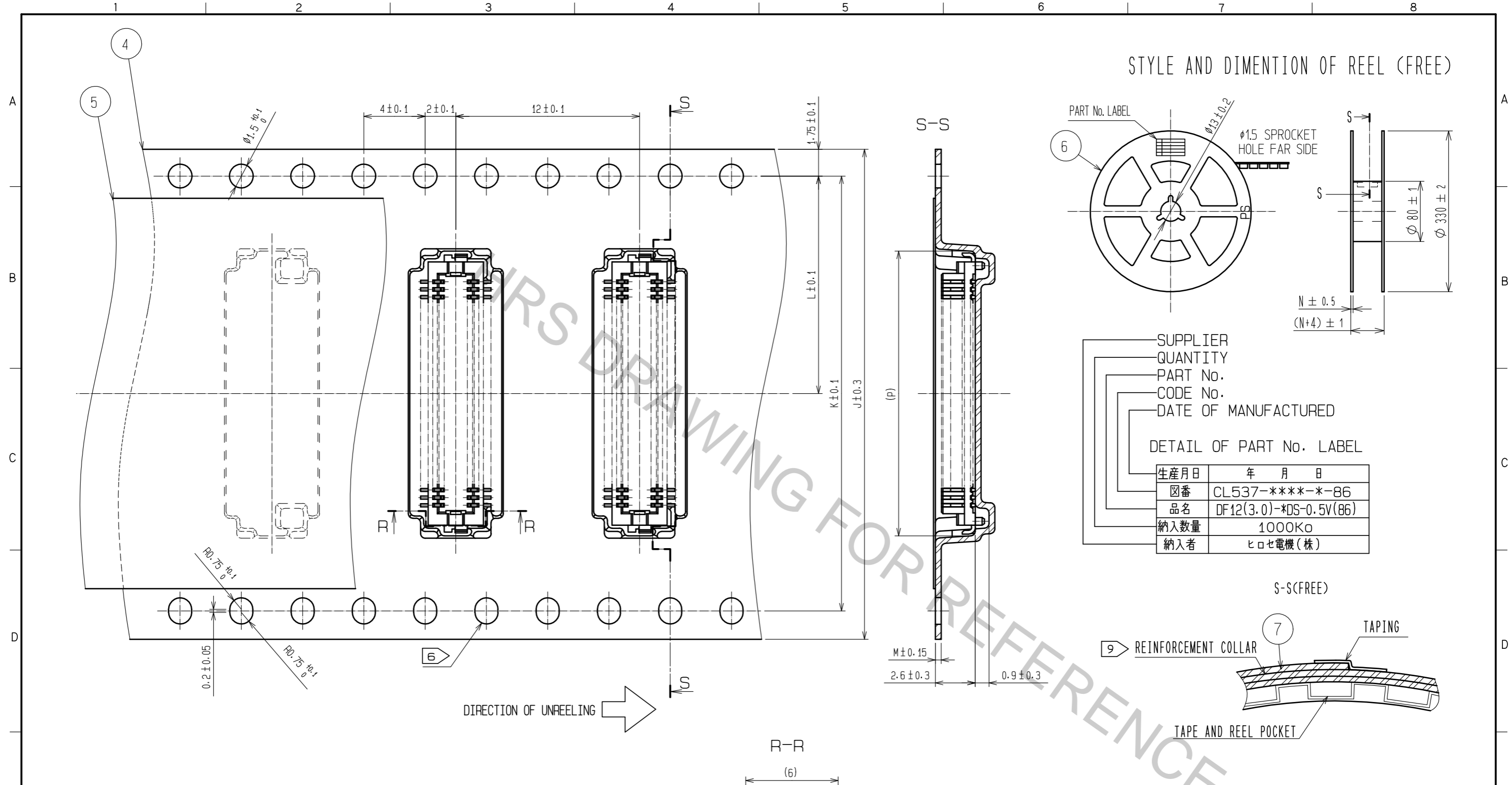

SUPPLIER
QUANTITY
PART No.
CODE No.
DATE OF MANUFACTURED

DETAIL OF PART No. LABEL

生産月日	年 月 日
図番	CL537-****-*86
品名	DF12(3.0)*DS-0.5V(86)
納入数量	1000K ϕ
納入者	ヒロセ電機(株)

CODE No.	CONTACT	J	K	L	M	N	P
CL537-0601-8-86	10	16	-	7.5	0.30	17.5	6.4
CL537-0914-3-86	14	16	-	7.5	0.30	17.5	7.4
CL537-0603-3-86	20	16	-	7.5	0.38	17.5	9
CL537-0605-9-86	30	24	-	11.5	0.38	25.5	11.5
CL537-0612-4-86	32	24	-	11.5	0.30	25.5	12
CL537-0606-1-86	36	24	-	11.5	0.38	25.5	12.6
CL537-0607-4-86	40	24	-	11.5	0.38	25.5	14
CL537-0609-0-86	50	24	-	11.5	0.38	25.5	16.1
CL537-0611-1-86	60	32	28.4	14.2	0.38	33.5	18.6
CL537-0613-7-86	80	44	40.4	20.2	0.38	45.5	23.8

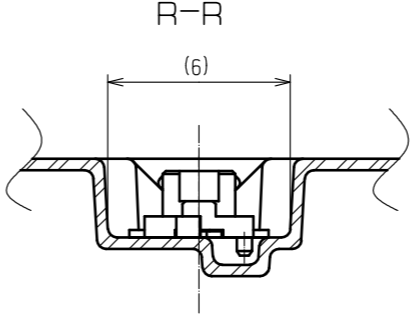

- NOTES
- 1 REEL 1000 CONNECTORS.
 - AT THE BEGINNING OF THE REEL, 30 COMPONENTS SHALL BE EMPTY. AT THE END OF THE REEL, 20 COMPONENTS SHALL BE EMPTY.
 - WHEN THE TAPE WIDTH IS 32 mm OR 44 mm, SPROCKET HOLES SHALL BE SET ON BOTH SIDE OF REEL AS SHOWN ON THIS DRAWING.
 - PEEL FORCE REFERS TO JIS C 0806. (IEC 60286-3)
 - THE REEL IS PACKED WITH A POLYETHYLENE MATERIAL, TOGETHER WITH A DRYING AGENT.
 - AFTER PACKING, ROLL 2 METERS OF THE REINFORCEMENT COLLAR TO OUTER CIRCUMFERENCE OF TAPE AND REEL POCKET, AND TAPE DOWN AT THE END THE COLLAR.

HRS	DRAWING NO.	EDC3-163504-77
	PART NO.	DF12(3.0)*DS-0.5V(86)
	CODE NO.	CL537
		2/2