

PART NUMBER	REV	FIRST USED
680395-1	B	122500-1
680395-2	B	565435-5
680395-3	B	354500-1

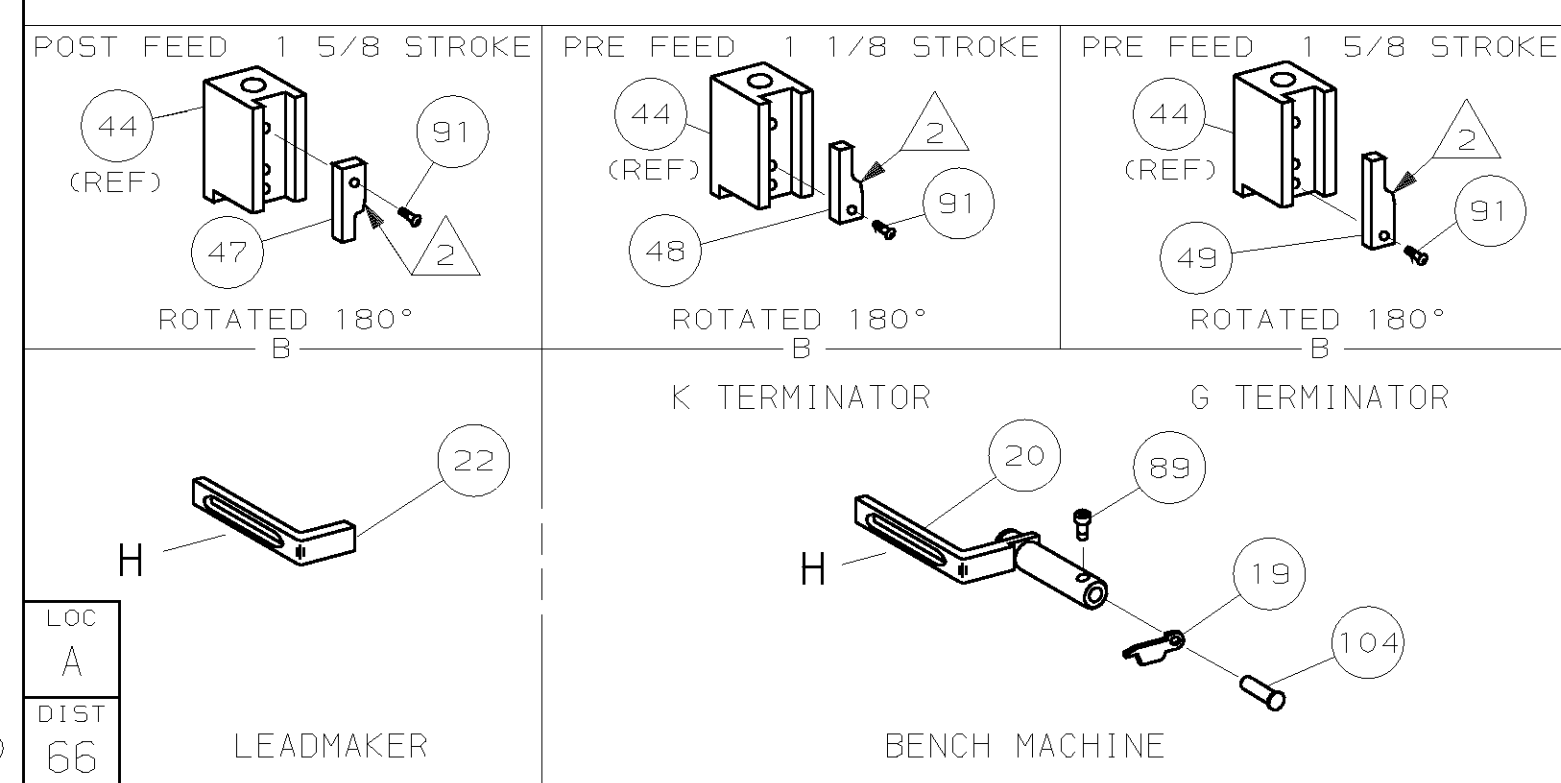
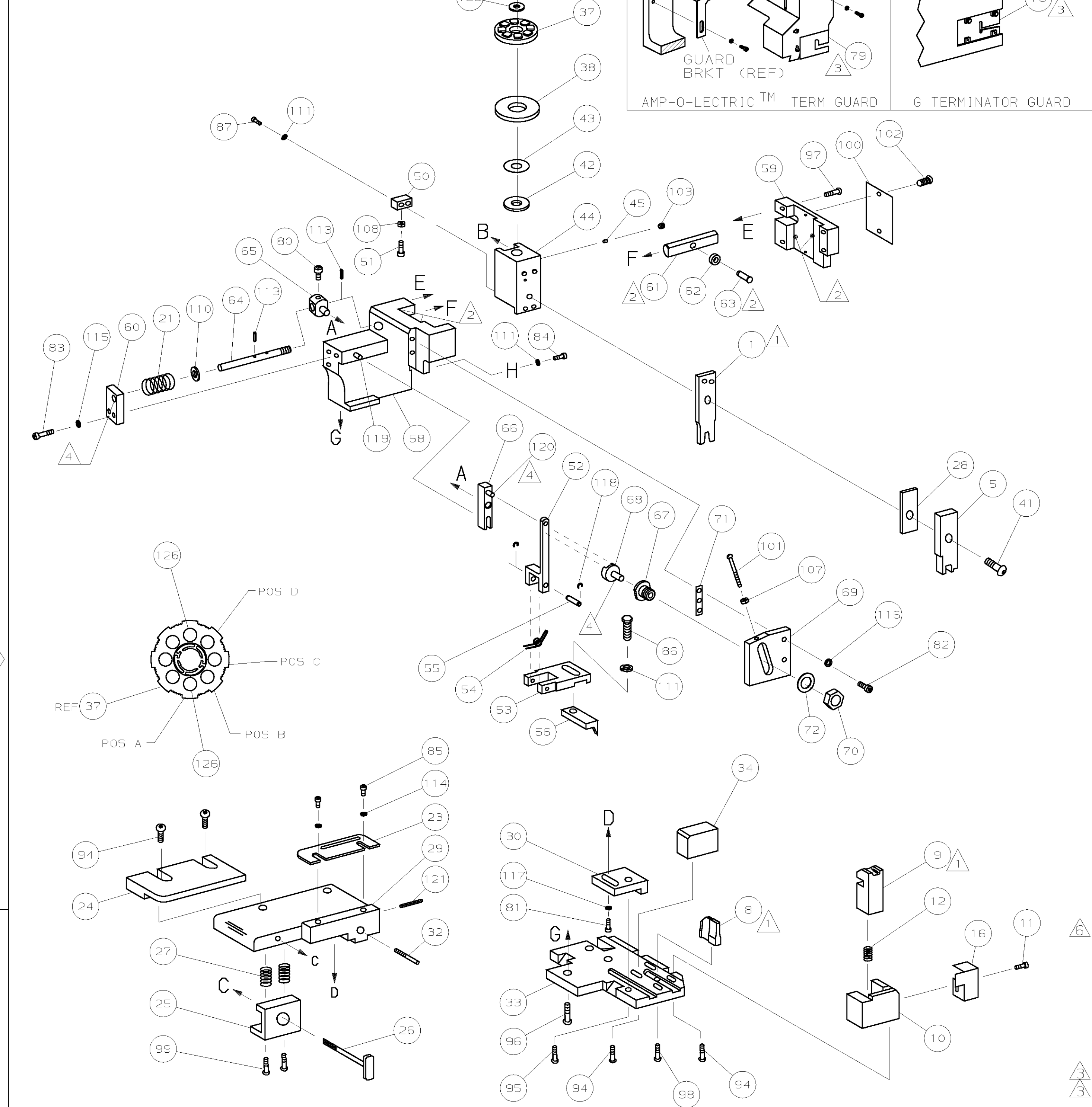

- 1 RECOMMENDED SPARE PARTS.
- 2 GREASE LIGHTLY.
- 3 GUARD MUST BE IN PLACE WHEN OPERATING APPLICATOR IN A BENCH MACHINE.
- 4 LUBRICATE DAILY USING NO. 20 MACHINE OIL.
- 5. ITEMS WITH QTY OF REF SPECIFIED (EXCEPT ITEMS 78 AND 79) ARE USED ON ITEM 46.
- 6 CUT TO LENGTH AT ASSY

TERMINAL NAME: AMP-IN™ TERMINAL					
		CRIMPING DATA			
PAD LTR	CRIMP HEIGHT	WIRE SIZE			
A	.034 ±.002 [0.86 ±0.05mm]	20			
B	-	-			
C	-	-			
D	-	-			
CRIMP	SIZE	TYPE	RANGE		
WIRE	.070 [1.778mm]	F	20		
INSUL	-	-	-		
WIRE STRIP LENGTH	TERM APPL SPEC	FEED	APPL INSTRUCTION	SET UP GAGE	LAYOUT
-	NONE	.500	408-8040	458637-1	L1845

QTY	REF	REF	REF	U/M	DWG SIZE	PART NO	DESCRIPTION	ITEM NO
1								129
1								128
2	2	2	-	C		5-354779-4	PIN, WIRE DISC (.3260)A	126
1	1	1	-	A		986950-1	WASHER, FLAT PRECISION	125
1	1	1	-	A		217238-1	GENERAL INSTRUCTION PACKAGE	124
1	1	1	-	-		4088040	SF APPL INST 408-8040	123
								122
1	1	1	-	A		4-21028-0	PIN, SLT SPR (ø.093x.75)ST GDE PL	121
REF	REF	REF	-	A		1-21030-1	PIN, DOWEL (ø.187x.50) LEVER	120
REF	REF	REF	-	A		1-21030-6	PIN, DOWEL (ø.187x1.25) HOUSING	119
REF	REF	REF	-	A		21045-3	RING, RET "C" (ø.187) FD FING PIN	118
1	1	1	-	A		21024-5	WASHER, LOCK (#10) ADJ BLK	117
REF	REF	REF	-	A		21024-5	WASHER, LOCK (#10) ADJ PLATE	116
REF	REF	REF	-	A		21024-5	WASHER, LOCK (#10) FEED GDE ROD	115
2	2	2	-	A		21024-2	WASHER, LOCK (#4) FRONT STP GUIDE	114
REF	REF	REF	-	A		5-21028-1	PIN, SLT SPR (ø.125x.50) ADJ ROD	113
								112
4	4	4	-	A		21024-4	WASHER, LOCK (#8) STRIPPER	111
REF	REF	REF	-	A		21899-4	WASHER, FLAT (ø5/16) SCREW ADJ	110
								109
1	1	1	-	A		21018-5	NUT, HEX (NO. 6) HOLDDOWN	108
REF	REF	REF	-	A		21018-5	NUT, HEX (6-32) FEED ADJ	107
								106
								105
1	1	-	-	A		992031-1	PIN, CLEVIS	104
1	1	1	-	A		21009-2	SCR, SKT 5ET (1/4-20x.25 LW) RAM	103
2	2	2	-	A		21017-2	SCR, DRIVE (#2x.19) ID PLATE	102
REF	REF	REF	-	A		6-23715-5	SCR, PAN HD (6-32x1.50) FEED ADJ	101
1	1	1	-	B		461264-1	PLATE, IDENTIFICATION	100
2	2	2	-	A		3-21002-0	SCR, BHC (10-32x.88) DRAG	99
1	1	1	-	A		22733-8	SCR, BHC (8-32x.38 LW) ANVIL	98
REF	REF	REF	-	A		2-21002-9	SCR, BHC (10-32x.75) CAP	97
REF	REF	REF	-	A		2-22733-8	SCR, BHC (1/4-20x.62) HOUSING	96
REF	REF	REF	-	A		2-21002-7	SCR, BHC (10-32x.50) 56 ADJ BLOCK	95
6	6	6	-	A		2-21002-2	SCR, BHC (8-32x.50) TERM H DWN	94
								93
								92
								91
1	1	1	-	A		1-21002-7	SCR, BHC (6-32x.38) CAM	90
								89
2	2	2	-	A		2-21000-7	SCR, SHC (8-32x.48) DEP-HOLD	87
1	1	1	-	A		2-22603-0	SCR, HEX HD (8-32x.31) FEED FINGER	86
2	2	2	-	A		1-21000-3	SCR, SHC (4-40x.25) F ST GUIDE	85
1	1	1	-	A		2-21000-7	SCR, SHC (8-32x.50) STRIPPER	84
REF	REF	REF	-	A		3-21000-7	SCR, SHC (10-32x.75) FEED ROD GD	83
REF	REF	REF	-	A		3-21000-6	SCR, SHC (10-32x.62) FD ADJ BLK	82
1	1	1	-	A		3-21000-4	SCR, SHC (10-32x.38) 56 ADJ BL	81
REF	REF	REF	-	A		3-21000-4	SCR, SHC (10-32x.38) PIVOT BLK	80
-	REF	-	-	B		455749-1	GUARD, WINDOW	79
REF	-	-	-	B		679532-1	INSERT, GUARD	78
								77
								76
								75
								74
								73
REF	REF	REF	-	A		458109-1	WASHER, SPECIAL	72
REF	REF	REF	-	A		690517-1	SPACER	71
-3	-2	-1	U/M	DWG SIZE		PART NO	DESCRIPTION	ITEM NO
QTY REOD PER ASSY			PARTS LIST					

			LEADMAKER	MECH POST FEED				
			BENCH MODEL K	MECH PRE FEED				
			BENCH MODEL G	MECH PRE FEED				
REF	REF	REF	-	B	22594-8	NUT, HEX (1/2-20)	70	
REF	REF	REF	-	B	240628-1	PLATE, ADJUSTMENT	69	
REF	REF	REF	-	B	240626-1	SHAFT, PIVOT	68	
REF	REF	REF	-	B	240633-1	BUSHING	67	
REF	REF	REF	-	A	455680-1	LEVER, INTERMEDIATE	66	
REF	REF	REF	-	B	240629-1	BLOCK, PIVOT	65	
REF	REF	REF	-	A	240632-2	SCREW, ADJ FEED ROD	64	
REF	REF	REF	-	B	240659-3	PIN, CAM ROLLER	63	
REF	REF	REF	-	B	240658-1	ROLLER, CAM	62	
REF	REF	REF	-	B	454398-2	ROD, FEED	61	
REF	REF	REF	-	A	454178-1	GUIDE, FEED ROD	60	
REF	REF	REF	-	C	454220-1	CAP, RAM	59	
REF	REF	REF	-	D	454485-1	HOUSING	58	
							57	
1	1	1	-	B	458537-2	PAWL, FEED	56	
REF	REF	REF	-	B	240624-1	PIN, FEED FINGER	55	
REF	REF	REF	-	B	691499-1	SPRING, FEED FINGER	54	
REF	REF	REF	-	B	690541-1	HOLDER, FEED FINGER	53	
REF	REF	REF	-	A	455679-1	LEVER, TERMINAL FEED ARM	52	
1	1	1	-	A	811242-2	BUMPER, HOLDDOWN	51	
1	1	1	-	A	690753-1	SPACER, TONKER	50	
1	-	-	-	B	690602-6	CAM, PRE-FEED 1 5/8 ST	49	
-	1	-	-	B	690602-5	CAM, PRE-FEED 1 1/8 ST	48	
-	-	1	-	B	690501-4	CAM, POST-FEED 1 5/8 ST	47	
1	1	1	-	B	459456-1	APPLICATOR, BASIC (SUBASSY)	46	
1	1	1	-	A	690191-1	PLUG, NYLON	45	
1	1	1	-	C	455673-1	RAM	44	
1	1	1	-	A	690125-1	WASHER, LAMINATED	43	
1	1	1	-	A	690124-1	WASHER, RAM	42	
1	1	1	-	A	7-21002-9	BOLT, CRIMPER (5/16x1.00)	41	
							40	
							39	
1	1	1	-	A	690223-2	SPACER, INSULATION DISC	38	
1	1	1	-	D	354777-1	WIRE DISC, PLASTIC	37	
1	1	1	-	A	22480-5	WASHER, SPRING	36	
1	1	1	-	B	690212-1	POST, RAM	35	
1	1	1	-	B	1-690786-3	SUPPORT, TERMINAL	34	
REF	REF	REF	-	D	455675-1	PLATE, BASE	33	
1	1	1	-	A	690432-3	SCREW, ADJUSTMENT	32	
							31	
REF	REF	REF	-	B	455689-1	BLOCK, STRIP GUIDE ADJ	30	
1	1	1	-	C	455671-1	PLATE, STRIP GUIDE	29	
1	1	1	-	C	1-455888-9	SPACER, FRONT SHEAR DEP	28	
2	2	2	-	A	1-22284-0	SPRING, DRAG	27	
1	1	1	-	B	690546-1	LEVER, DRAG RELEASE	26	
1	1	1	-	B	240792-1	DRAG, TERMINAL	25	
1	1	1	-	D	8-690504-0	GUIDE, STRIP (REAR)	24	
1	1	1	-	A	690438-1	GUIDE, STRIP (FRONT)	23	
-	-	1	-	B	690472-2	STRIPPER	22	
REF	REF	REF	-	A	4-22284-9	SPRING, FEED RETURN	21	
1	1	-	-	A	679218-1	STRIPPER WIRE STOP ASSY	20	
1	1	-	-	B	458949-1	STRIPPER	19	
							18	
							17	
1	1	1	-	B	318563-1	GUARD, CHIP, FRONT	16	
							15	
							14	
							13	
1	1	1	-	A	5-22280-0	SPRING, SHEAR	12	
1	1	1	-	B	690461-1	STOP, SHEAR	11	
1	1	1	-	C	690459-1	HOLDER, SHEAR (FRONT)	10	
1	1	1	-	C	454276-1	SHEAR, FLOAT (FRONT)	9	
1	1	1	-	C	9-683403-5	ANVIL	8	
							7	
							6	
1	1	1	-	C	1-455889-4	DEPRESSOR, SHEAR (FRONT)	5	
							4	
							3	
							2	
1	1	1	-	C	3-456404-5	CRIMPER, WIRE	1	
-3	-2	-1	U/M	DWG SIZE		PART NO	DESCRIPTION	ITEM NO
QTY REOD PER ASSY			PARTS LIST					

LOC A	DIST 66	AMP 1756 REV 3-92	23-JUL-04	12:23:49	us016926	8	7	6	5	4	3	2	1																												
THIS DRAWING IS UNCONTROLLED UNLESS INDICATED OTHERWISE		RELEASED FOR PUBLICATION MAY 21, 1999		BY AMP INCORPORATED. ALL RIGHTS RESERVED.		<p>REVISION RECORD</p> <table border="1"> <thead> <tr> <th>REV</th> <th>DATE</th> <th>DESCRIPTION</th> </tr> </thead> <tbody> <tr> <td>B</td> <td>ECN 0150-0942-04</td> <td></td> </tr> <tr> <td>A</td> <td>REVISED</td> <td></td> </tr> </tbody> </table>		REV	DATE	DESCRIPTION	B	ECN 0150-0942-04		A	REVISED		<p>REVISION RECORD</p> <table border="1"> <thead> <tr> <th>REV</th> <th>DATE</th> <th>DESCRIPTION</th> </tr> </thead> <tbody> <tr> <td>CE</td> <td>1-97</td> <td></td> </tr> <tr> <td>APP</td> <td></td> <td></td> </tr> </tbody> </table>		REV	DATE	DESCRIPTION	CE	1-97		APP			<p>TE 7-04</p> <p>REMOVE BURRS, BREAK SHARP EDGES R.015 MAX</p>		<p>MATL</p> <p>HT TR</p> <p>FIN</p>		<p>DR 11-18-96</p> <p>P.MCCARTY</p> <p>CHK 11-18-96</p> <p>C.ERISMAN</p>		<p>APP 11-18-96</p> <p>T.ELBIN</p> <p>REL</p>		<p>AMP Incorporated</p> <p>Harrisburg, PA 17105-3608</p>		<p>NAME</p> <p>SCALE</p>		<p>MACHINE REF</p> <p>MINI APPL</p>	
REV	DATE	DESCRIPTION																																							
B	ECN 0150-0942-04																																								
A	REVISED																																								
REV	DATE	DESCRIPTION																																							
CE	1-97																																								
APP																																									
SIDE FEED HDM APPLICATOR												680395		SHEET 1 OF 1		REV B																									
CUSTOMER AND ASSEMBLY DRAWING														RESTRICTED TO																											