

Figure 1

1. INTRODUCTION

This instruction sheet covers the use and maintenance of AMP* 2mm HM Shield Seating Tools 122562-1 and 122563-1. These tools are designed to install Lower Ground Return Shields over already seated receptacles of the Z-PACK 2mm HM Interconnection System. The shields contain ACTION PIN contacts to allow solderless printed circuit (pc) board installation. See Figure 1.

NOTE All dimensions on this document are in metric units [with U.S. customary units in brackets].

Read these instructions and understand them before using the seating tools.

Reasons for reissue are provided in Section 8, REVISION SUMMARY.

2. DESCRIPTION

The seating tools are each a one-piece aluminum design.

During seating, Seating Tool 122563-1 covers the receptacle and shield, and presses on the top surface of the shield when the applicator ram applies force to the seating tool. Seating Tool 122562-1 is positioned into a pc board support fixture to support the pc board and connector from the bottom.

3. REQUIREMENTS

3.1. PC Board Support Fixture

A pc board support must be used to provide proper support for the pc board and alignment of the seating tool to the shield pins, and to protect the pc board and shield contacts from damage. AMP PC Board Support Fixture 679980-[] is available and recommended for use with these seating tools. For proper selection and detailed information, refer to instruction sheet 408-4038.

NOTE *As an alternative, you can design a pc board support fixture for your specific needs, using the recommendations in 408-6927.*

3.2. Application Tooling

Power for seating tool must be provided by a machine capable of supplying a downward force of 89 Newtons (N) [20 lb] per contact. You may use AMP 10/20-Ton "H"-Frame Assembly 803880-6 (Customer Manual 409-5567 provides instructions) or AMP SM-3 Frame Assembly 814700-2 (409-5626).

4. SEATING LOWER SHIELDS

1. Set seating height to the dimension shown in Figure 2. (Applicator shut height will equal the seating height PLUS the combined thicknesses of Seating Tool 122562-1 and the pc board support.)
2. Position Seating Tool 122562-1 into the pc board support fixture and centered under the

applicator ram of the power source. Position pc board over the seating tool so that the connector and upper shield are supported.

3. Position shield into pc board so that shield contacts are properly aligned to the pc board and receptacle. See Figure 2.
4. Insert shield contacts into pc board until the compliant sections of the ACTION PIN contacts are resting securely on, but have not fully entered, the pc board.
5. Position Seating Tool 122563-1 onto the shield.
6. Center Seating Tool 122563-1 and shield under the applicator ram of the power source; slowly lower ram until it just meets the seating tool. Verify the alignment of the board support, pc board, connector, shield, and both seating tools.

CAUTION *Damage to the pc board, tool, shields, or connector may occur if seating height is improperly set, if pc board is not properly positioned over the supporting seating tool, or if tool is not properly seated on the shield before cycling the applicator ram.*

7. Cycle applicator ram according to instructions for the power source. Check assembly for proper seating using the requirements in Figure 2.
8. Remove pc board with receptacle and seated shield, or reposition board and board support for seating additional shields.

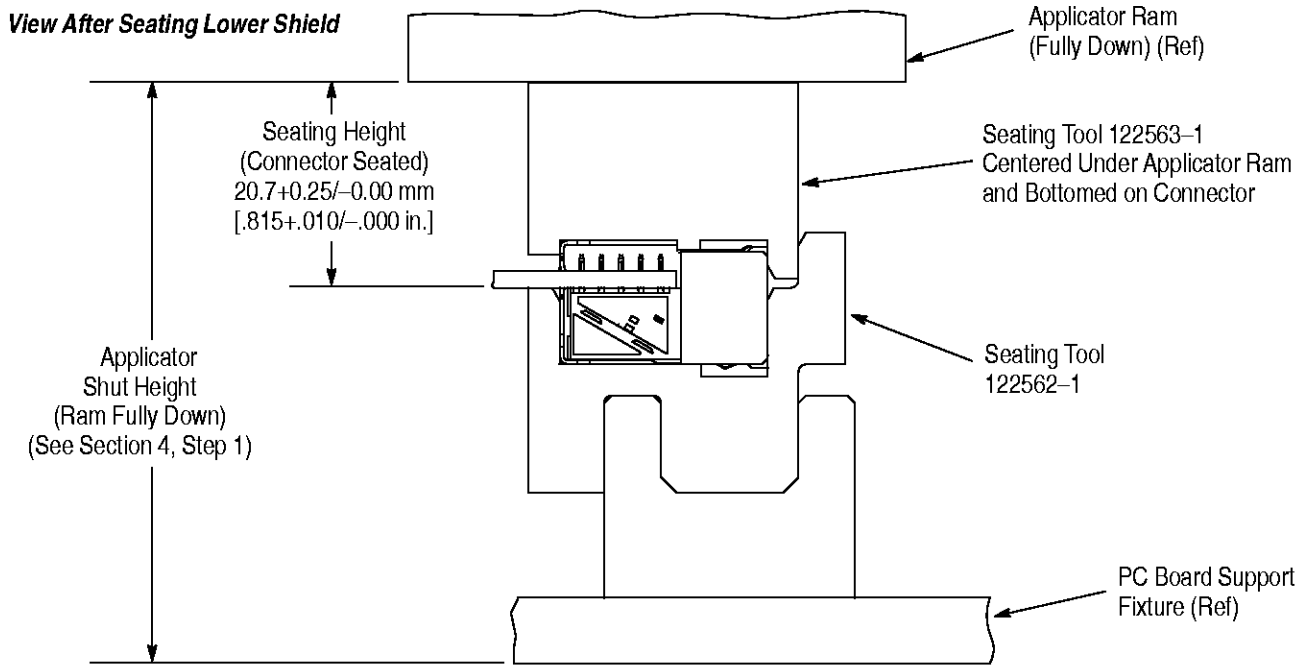

NOTE: Not to scale.

Figure 2

5. TOOL INSPECTION

The seating tools are inspected before shipment. It is recommended that the tools be inspected, using Figure 3, immediately upon their arrival at your plant to ensure that they have not been damaged during shipment.

Regular inspection should be performed by quality control personnel. A record of scheduled inspections should remain with the tool or be supplied to supervisory personnel responsible for the tool. The inspection frequency should be based on the amount of use, working conditions, operator training and skill, and established company standards.

6. MAINTENANCE

It is recommended that each operator be made aware of, and responsible for, the following steps of daily maintenance:

1. Remove dust, moisture, and other contaminants with a clean, soft brush, or lint-free cloth. Do NOT use objects that could damage the tools.
2. When the tools are not in use, store them in a clean, dry area.

7. ORDERING INFORMATION AND REPAIR

Order additional tools through your AMP representative, or call 1-800-526-5142, or send a facsimile of your purchase order to 1-717-986-7605 or write to:

CUSTOMER SERVICE (038-035)
 AMP INCORPORATED
 P.O. BOX 3608
 HARRISBURG, PA 17105-3608

Tools may be returned to AMP for evaluation and repair. For repairs, send tool, with a written description of the problem, to:

CUSTOMER REPAIR (01-12)
 AMP INCORPORATED
 1523 NORTH 4TH STREET
 HARRISBURG, PA 17102-1604

8. REVISION SUMMARY

Since the previous release of this sheet, the following changes were made:

Per EC 0990-1445-98:

- Updated Figures 1 and 2 to show new lower shield and receptacle with integral shield
- Revised Section 1, INTRODUCTION
- Changed downward force from 90 Newtons to 89 Newtons in Paragraph 3.2

**Seating Tool
122562-1**

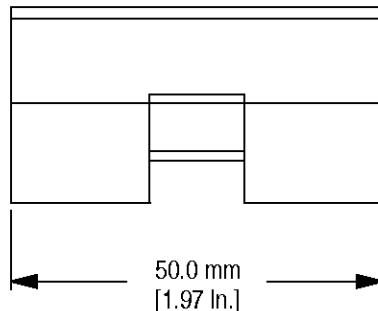

**Seating Tool
122563-1**

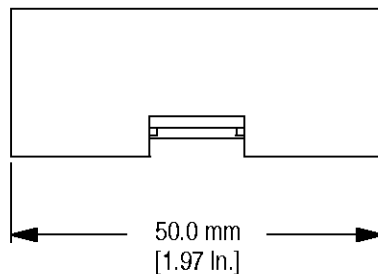

Figure 3