

THIS DRAWING IS UNPUBLISHED. RELEASED FOR PUBLICATION ,19 .  
 © COPYRIGHT 19 BY AMP INCORPORATED. ALL RIGHTS RESERVED.

LOC		DIST		REVISIONS			
P	LTR	DESCRIPTION		DATE	DWN	APVD	
	B	REDRAWN PER 0720-0470-95		23JAN95	LO	ME	

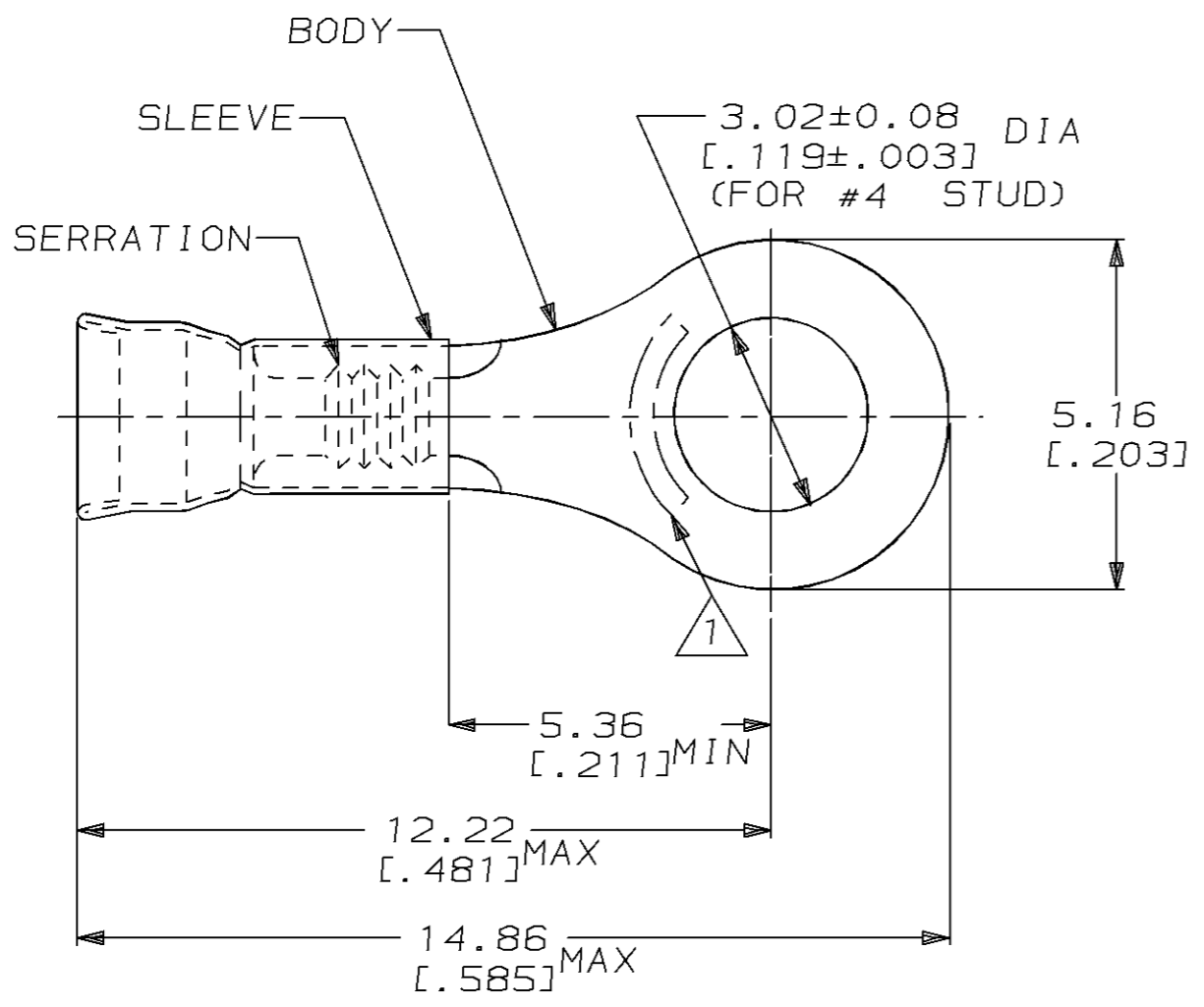

△ STAMP AMP LOCATE APPROX AS SHOWN

- 2. WIRE INSUL DIA, 1.27-2.08 [.050-.082]
- 3. TONGUE MATL THK, 0.46±0.05 [.018±.002]

5000	ON TAPE, REEL	2-31679-1
1000	LOOSE PIECE	31679
QTY	PACKAGE TYPE	PART NO

**AMP INCORPORATED**  
**CUSTOMER SERVICE SYSTEM**

FOR ADDITIONAL PRODUCT INFORMATION OR COPIES OF DRAWINGS AND TECHNICAL DOCUMENTS: PRODUCT INFORMATION CENTER 1-800-522-6752

FOR APPLICATION TOOLING INFORMATION: TOOLING ASSISTANCE CENTER 1-800-722-1111

FOR ORDER ENTRY: 1-800-526-5142

MAX RECOMMENDED OPERATING TEMPERATURE: -

VOLTAGE RATING: -

CIRCULAR MIL AREA: 0.10mm<sup>2</sup>-0.41mm<sup>2</sup> [202-810]

STRANDED WIRE

THIS DRAWING IS A CONTROLLED DOCUMENT FOR AMP INCORPORATED. IT IS SUBJECT TO CHANGE AND THE CONTROLLING ENGINEERING ORGANIZATION SHOULD BE CONTACTED FOR THE LATEST REVISION.

DIMENSIONS:	TOLERANCES UNLESS OTHERWISE SPECIFIED:
mm [in]	
	0 PLC ±-
	1 PLC ±-
	2 PLC ±0.20 [.008]
	3 PLC ±-
	4 PLC ±-
	ANGLES ±-

MATERIAL: BODY, CU, SLV, CU PER ASTM B152

FINISH: TIN PLATE PER MIL-T-10727

DWN	L OLMEDA	23JAN95	<b>AMP</b> AMP Incorporated Harrisburg, PA 17105-3608			
CHK	M ELLIS	23JAN95				
APVD	S BORTNER	23JAN95				
NAME	TERMINAL, RING, DIAMOND GRIP, WIRE SIZE, 26-22 AWG					
PRODUCT SPEC	-		SIZE	CAGE CODE	DRAWING NO	
APPLICATION SPEC	-		A3	00779	C-31679	
WEIGHT	-		CUSTOMER DRAWING	SCALE	SHEET	REV
			8:1	1 OF 1	B	