

NOTA:  
 - ( ) = Pour information uniquement  
 NOTE:  
 - ( ) = Only for information

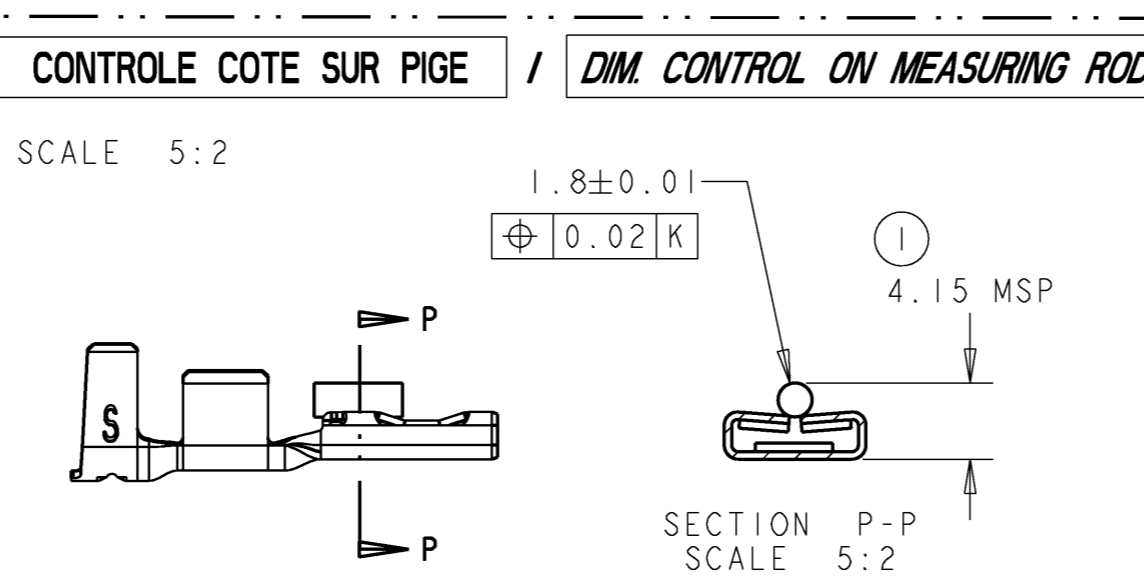

SERTISSAGE / CRIMPING

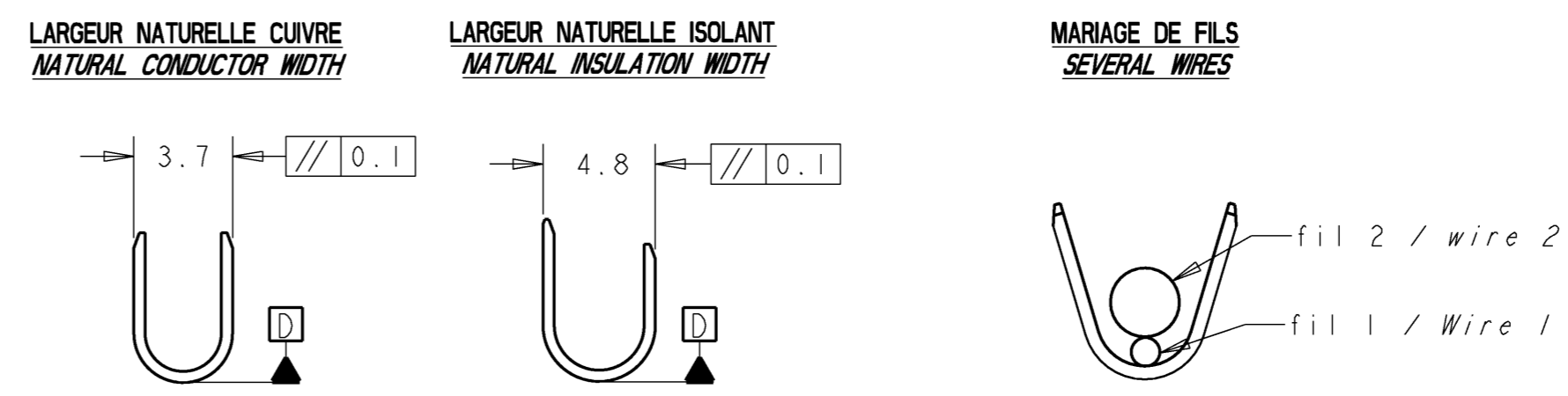

NOTICE DE CONTROLE DU CLIP SERTI / CONTROLE NOTICE OF CRIMPING TERMINAL

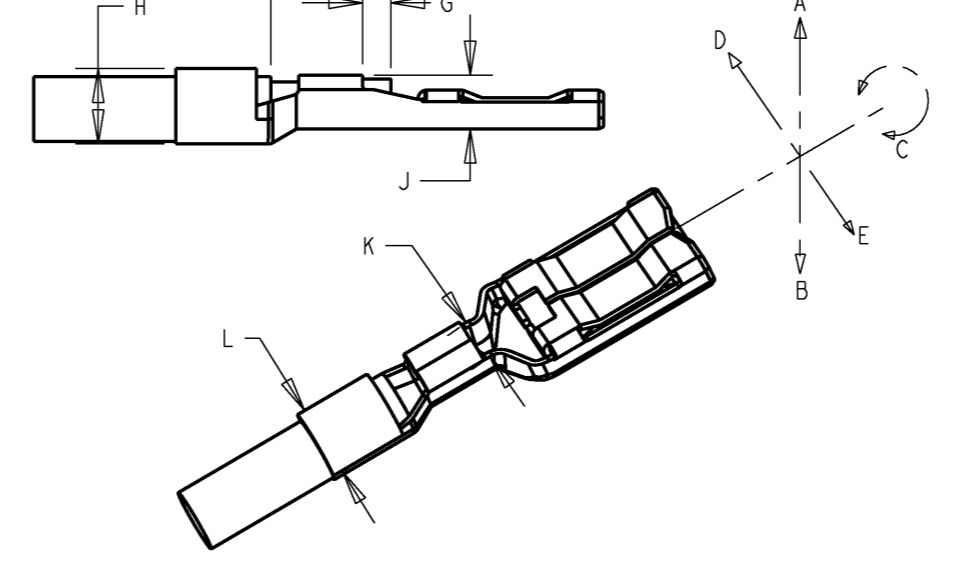

CARACTERISTIQUES A VERIFIER CHARACTERISTICS TO CHECK		VALEUR VALUE	REPERE ITEM
DEFORMATION APRES SERTISSAGE DEFORMATION AFTER CRIMPING	FLEXION VERS LE HAUT / UP BENDING	2°	A
	FLEXION VERS LE BAS / DOWN BENDING	2°	B
	TORSION / TWIST	5°	C
DEFORMATION SUIVANT L'AXE DE LA PIECE / AXIAL DEFORMATION		2°	D - E
LONGUEUR DE DENUDAGE / STRIPPING LENGTH		6.5 <sup>+0.5</sup> <sub>0</sub>	F
DEPASSEMENT DU FIL / WIRE EXCESS		0.3 <sup>+0.5</sup> <sub>0</sub>	G

TENUE EN TRACTION DU SERTISSAGE CUIVRE:

- LA TENUE EN TRACTION DU SERTISSAGE CUIVRE EST MESUREE APRES 10 SECONDES D'APPLICATION DE L'EFFORT MENTIONNE AU TABLEAU "PARAMETRES DE SERTISSAGE" EFFORT APPLIQUE SUIVANT L'AXE DU CLIP; SERTISSAGE SUR ISOLANT NEUTRALISE.

- A L'ISSUE DE L'ESSAI ON NE DOIT AVOIR CONSTATE AUCUN GLISSEMENT DE L'AME DU FIL. LE NON RESPECT DE CETTE SANCTION ENTRAINE LE REFUS DU LOT CONSIDERE.

- L'OPERATION DE SERTISSAGE NE DOIT EN AUCUN CAS MODIFIER LA VALEUR DE LA COTE : ①

PULLING FORCE OF CONDUCTOR CRIMPING:

- THE PULLING FORCE OF CONDUCTOR CRIMPING IS MEASURED AFTER 10 SECOND OF THE "CRIMPING PARAMETERS" TABLE FORCE. FORCE IN THE TERMINAL AXIS DIRECTION, WITHOUT INSULATION CRIMPING.

- AFTER THE TEST, CONTROL THE UNSLIDING OF CONDUCTOR FROM WIRE. NO RESPECT OF THIS ISSUE WILL INVOLVE THE REJECTION OF THE SET

- THE CRIMPING OPERATION MUST NOT AFFECT THE DIMENSION : ①

TENUE AU PLIAGE DU SERTISSAGE ISOLANT :

L'essai est réalisé dans les conditions suivantes :  
 Le contact étant maintenu immobilisé, le conducteur subit 10 fois le cycle suivant :  
 - position initiale : conducteur/contact alignés  
 - pliage du conducteur à 45°  
 - pliage du conducteur à 45° opposé  
 - retour à la position initiale.

Le conducteur est tenu, sans traction excessive, à une distance correspondant à 20 fois son diamètre avec un minimum de 60 mm.

A L'ISSUE DU TEST ON NE DOIT OBSERVER AUCUN RETRAIT DE L'ISOLANT SOUS LES AILLETTES DE SERTISSAGE OU OUVERTURE DU DIT SERTISSAGE.

LE NON RESPECT DE CES SANCTIONS ENTRAINE LE REFUS DU LOT CONSIDERE.

INSULATOR BARREL BENDING RESISTANCE

The test is performed as following :  
 Receptacle maintain in position, the wire suffer 10 cycles as :  
 - initial position : conductor/wire horizontal  
 - wire bending to 45°  
 - wire bending to 45° opposite  
 - return to initial position.

The wire is maintain without extreme traction effort, at a distance corresponding to 20 diameter with a minimum of 60 mm

TEST ISSUE : NO SLIPPING OF INSULATOR OR OPENING OF THE BARREL  
 NO RESPECT OF THIS ISSUE WILL INVOLVE THE REJECTION OF THE SET

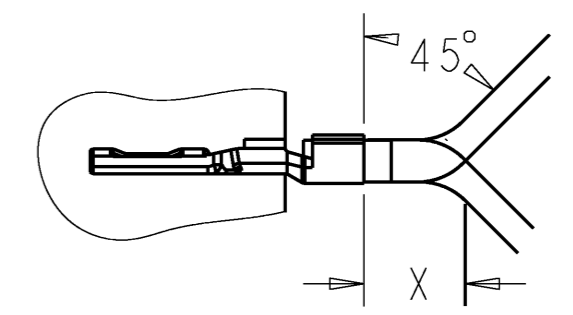

SECTION	X mini
2.5mm2	60 mm
6mm2	120 mm

NOTA / NOTE :

- Ce produit devra être conforme au sous-paragraphe "prohibition et restriction de substance" de la norme TS20001G.

- This part shall conform to sub-paragraph "substance prohibition and restriction" in TS20001G.

MISE EN BANDE ET CONDITIONNEMENT / PACKAGING

VOIR SPEC 107-15606 /  
 SEE SPECIFICATION 107-15606

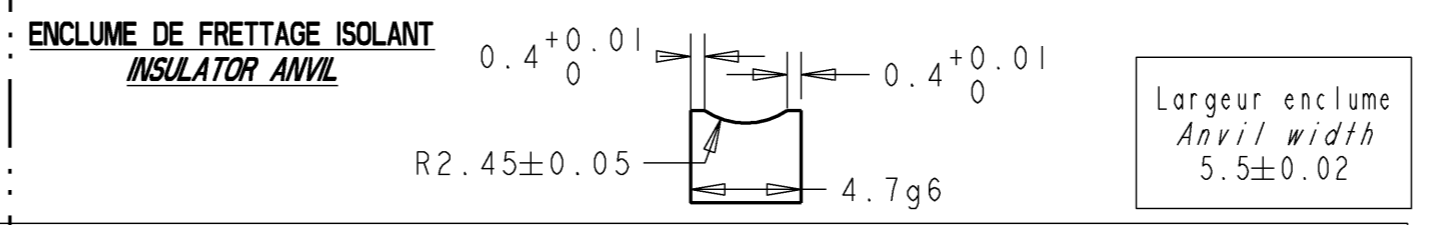
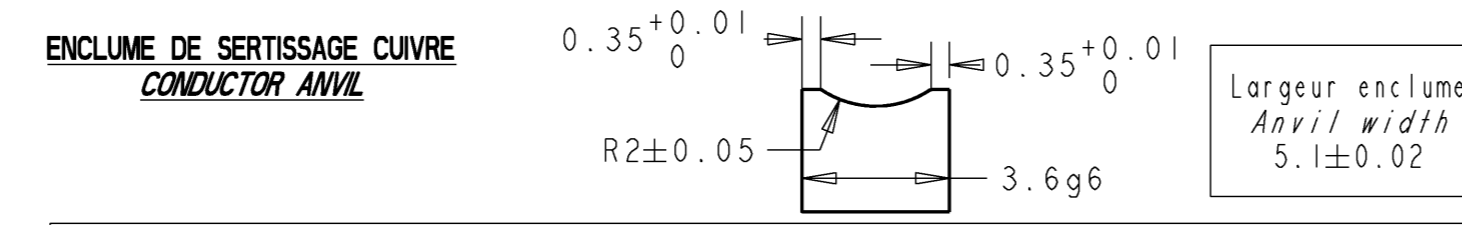
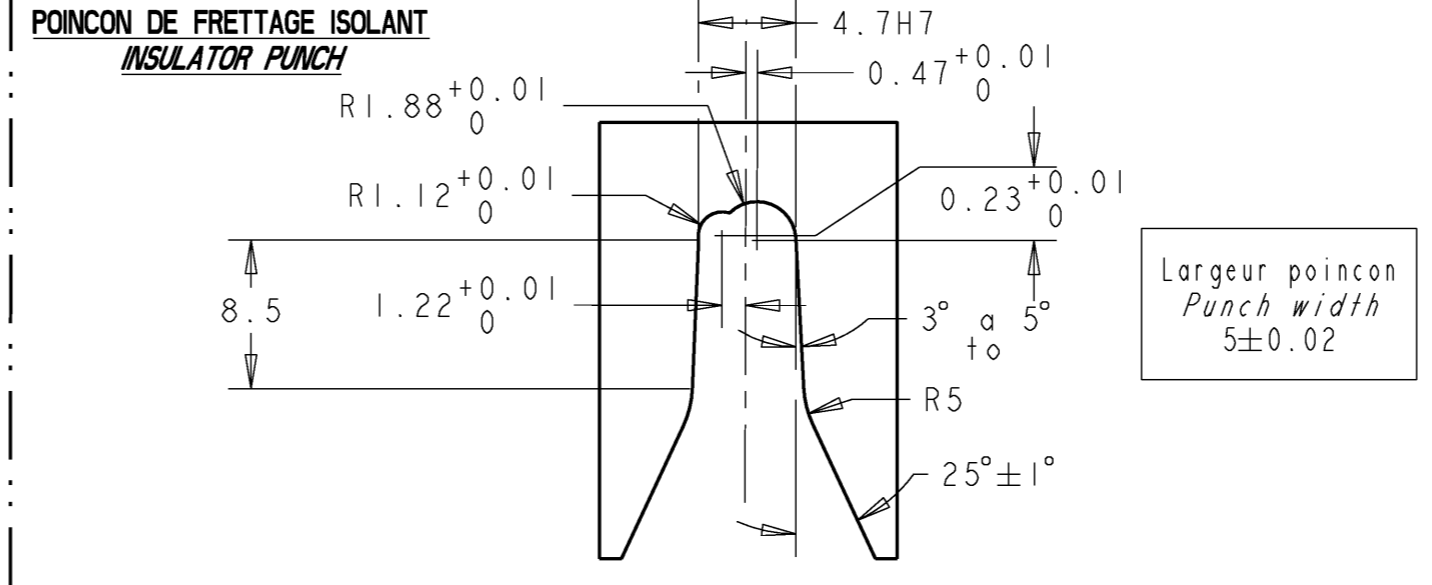
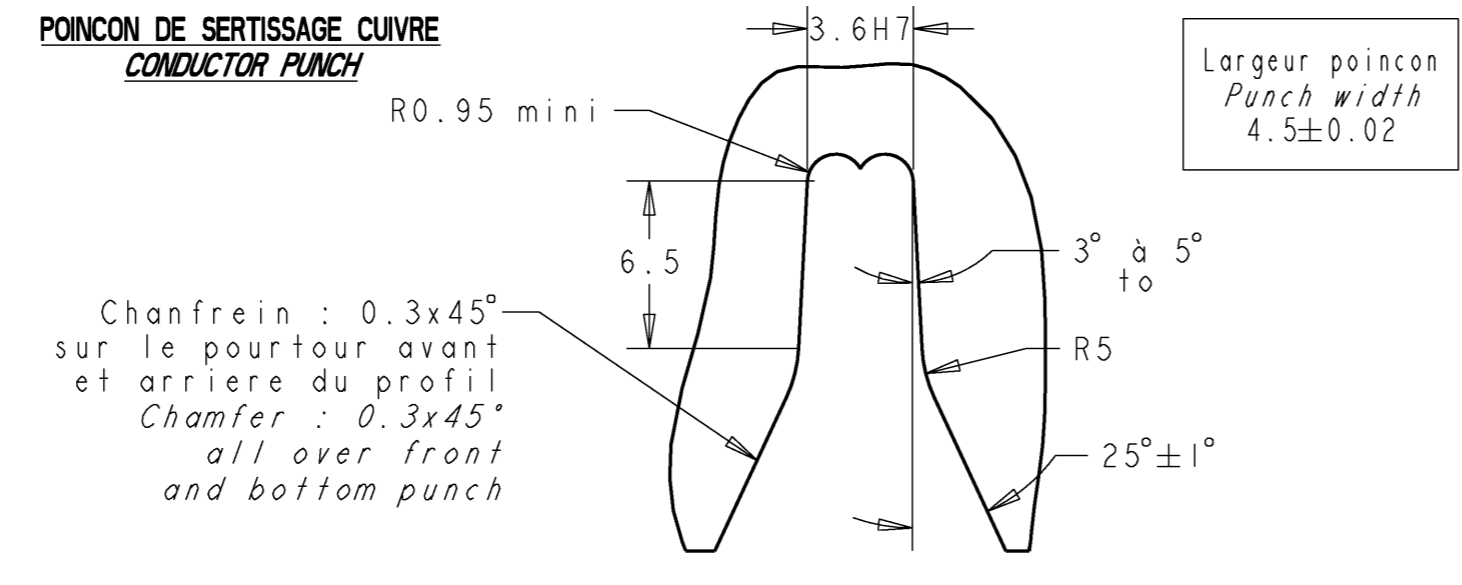

PARAMETRES DE SERTISSAGE / CRIMPING PARAMETERS												
SERTISSAGE DU CUIVRE CONDUCTOR CRIMPING	LONGUEUR D'AILE / LAYOUT : 12.2 EPAISSEUR METAL / METAL THICKNESS : 0.4						FRETTAGE DE L'ISOLANT (par recouvrement) INSULATOR CRIMPING (Overlapping)			LONGUEUR D'AILE / LAYOUT : 15.8 EPAISSEUR METAL / METAL THICKNESS : 0.4		
	SECTION	REELLE REAL	LARGEUR WIDTH	HAUTEUR HEIGHT	TRACTION (N) TRACTION EFFORT (N)			CONFIGURATION	ISOLANT INSULATOR	SURFACE SURFACE	LARGEUR WIDTH	HAUTEUR HEIGHT
TYPE DE FIL WIRE TYPE	mm2	K ± 0.1	J ± 0.05	FIL 1 WIRE 1	FIL 2 WIRE 2	FIL 1+2 WIRE 1+2	TYPE DE FIL WIRE TYPE	Ø EQUIVALENT <sup>+0.1</sup> <sub>-0.05</sub>	A FRETTER TO CRIMP	L ± 0.1	H ± 0.1	
IRI + 2RI	2.76	3.68	2.25	>140	>220	>300	IRI + 2RI	3.3	8.55	4.84	4.50	
3RI	3.02	3.68	2.30	>300	-	-	3RI	3.2	8.04	4.81	4.45	
1.4RI + 2RI	3.17	3.69	2.32	>180	>220	>340	1.4RI + 2RI	3.5	9.62	4.86	4.60	
3RIS / 3R3S / 3R4S	3.18	3.69	2.35	>300	-	-	3RIS / 3R3S / 3R4S	3.2	8.04	4.80	4.45	
0.6RI + 3RI	3.61	3.70	2.40	>100	>280	>360	0.6RI + 3RI	/	/	4.87	4.65	
2RI + 2RI	3.64	3.70	2.41	>220	>220	>400	2RI + 2RI	3.7	10.75	4.85	4.65	
IRI + 3RI	3.95	3.71	2.41	>140	>280	>400	IRI + 3RI	3.8	11.34	4.88	4.70	
4R3S	3.95	3.71	2.41	>400	-	-	4R3S	3.6	10.18	4.83	4.70	
1.4RI + 3RI	4.36	3.71	2.47	>180	>280	>440	1.4RI + 3RI	3.9	11.95	4.92	4.70	
5RIS / 5R3S / 5R4S	4.95	3.72	2.57	>450	-	-	5RIS / 5R3S / 5R4S	3.9	11.94	4.85	4.72	
3NI	3.02	3.68	2.30	>300	-	-	3NI	3.7	10.75	4.85	4.65	
4NI	/	/	/	/	/	/	4NI	/	/	/	/	
5NI	4.65	3.72	2.52	>450	-	-	5NI	4.4	15.20	4.90	4.85	
6 <sup>0</sup>	5.45	3.72	2.63	-	-	-	6 <sup>0</sup>	4.1	13.2	4.88	5.02	
2.5 ID ZH	2.62	3.70	2.20	-	-	-	2.5 ID ZH	2.8	6.16	4.80	3.95	
1 + 2.5 ID ZH	3.55	3.70	2.38	-	-	-	1 + 2.5 ID ZH	3.5	9.62	4.86	4.60	
4 ID ZH	3.96	3.71	2.41	>400	-	-	4 ID ZH	3.8	11.34	4.83	4.70	
6 ID ZH	5.94	3.74	2.70	-	-	-	6 ID ZH	4.1	13.2	4.87	5.02	

Tyco Electronics PN	1544133-1
CUSTOMER PN	

THIS DRAWING IS CONTROLLED DOCUMENT FOR TYCO ELECTRONICS CORPORATION. IT IS SUBJECT TO CHANGE AND THIS CONTROLING ORGANIZATION SHALL BE NOTIFIED BY THE CUSTOMER IN WRITING. THIS DRAWING IS CONTROLLED DOCUMENT FOR TYCO ELECTRONICS CORPORATION. IT IS SUBJECT TO CHANGE AND THIS CONTROLING ORGANIZATION SHALL BE NOTIFIED BY THE CUSTOMER IN WRITING.

DMW/PRES/INE 14sep05  
 P. FLORES  
 C. VERITE  
 L. CORONELLI

DATE: 14sep05  
 DATE: 16sep05

NAME: CLIP 6.35 NGI GAMME 2.5 A 6mm2  
 6.35 NGI TERMINAL RANGE 2.5 to 6mm2

WEIGHT/MASSE APPROX. 0.00093kg  
 CUSTOMER DRAWING / PLAN CLIENT POUR REFERENCE

SCALE: 5:1  
 SHEET: 1 OF 1